

TOPVERT L1 series

QUICK START

快速安裝手冊

**General purpose micro drive
Sensorless Vector Control**

簡易迷你型 無感電流向量控制 變頻器

ISO 9001:2008



PREFACE

Thank you for choosing TOPTEK'S TOPVERT L1 Series Drive. TOPVERT L1 Series are Sensorless current vector control high-performance drive. They were manufactured by adopting high-quality components, material and incorporating the latest microprocessor technology available.

Copyright statement







All information in this Quick start manual is Toptek's intellectual property. Even we had done our best to make this manual but are unable to guarantee 100% correct. Based on " Never Stop for better but perfect accomplished " quality policy, our product permanently in the journey which perfectly strives for perfection to the pursue, Therefore we reserve the right to change the information in this manual without prior notice. But we will continue the latest edition document in our website, for free download.

<http://www.toptek.biz>

Getting Started

This manual will be helpful in the installation, parameter setting, troubleshooting, and daily maintenance of the drives. To guarantee safe operation of the equipment, read the following safety guidelines before connecting power to the Drives. Keep this operating manual handy and distribute to all users for reference.

WARNING

-
-  Always read this manual thoroughly before using TOPVERT L1 Series Drives.
 -  **DANGER!** AC input power must be disconnected before any maintenance.
Do not connect or disconnect wires and connectors while power is applied to the circuit. Maintenance must be performed by qualified technicians.
 -  **CAUTION!** There are highly sensitive MOS components on the printed circuit boards. These components are especially sensitive to static electricity.
To avoid damage to these components, do not touch these components or the circuit boards with metal objects or your bare hands.
 -  **DANGER!** A charge may still remain in the DC-link capacitor with voltages even if the power has been turned off.
To avoid personal injury, please ensure that power has turned off before operating Drive and wait ten minutes for capacitors to discharge to safe voltage levels.
 -  **CAUTION!** Ground the TOPVERT L1 using the ground terminal.
The grounding method must comply with the laws of the country where the Drive is to be installed. Refer to Basic Wiring Diagram.
 -  **DANGER!** The Drive may be destroyed beyond repair if incorrect cables are connected to the input/output terminals. Never connect the Drive output terminals U/T1, V/T2, and W/T3 directly to the AC main circuit power supply.
 -  **CAUTION!** The final enclosures of the Drive must comply with EN50178. (Live parts shall be arranged in enclosures or located behind barriers that meet at least the requirements of the Protective Type IP20.
The top surface of the enclosures or barrier that is easily accessible shall meet at least the requirements of the Protective Type IP40).

(TOPVERT L1 Series corresponds with this regulation.)

CAUTION! Heat sink may heat up over 70°C (158°F), during the operation. Do not touch the heat sink.

CAUTION! The rated voltage for the drive must be ≤ 240V (≤ 480V for 460V models, ≤ 600V For 575V models) and the mains supply current capacity must be ≤ 5000A RMS (≤10000A RMS for the ≥ 40hp (30kW) models).

CAUTION! The leakage current between chassis and earth could be up to 22mA.

CAUTION! The load motor should meet IEC:60034-1 standard.

Nameplate Information

Example for 3HP/2.2kW 230V 1&3-Phase , Kneading board operation,RS-485 Serial port , dynamic braking resistor.

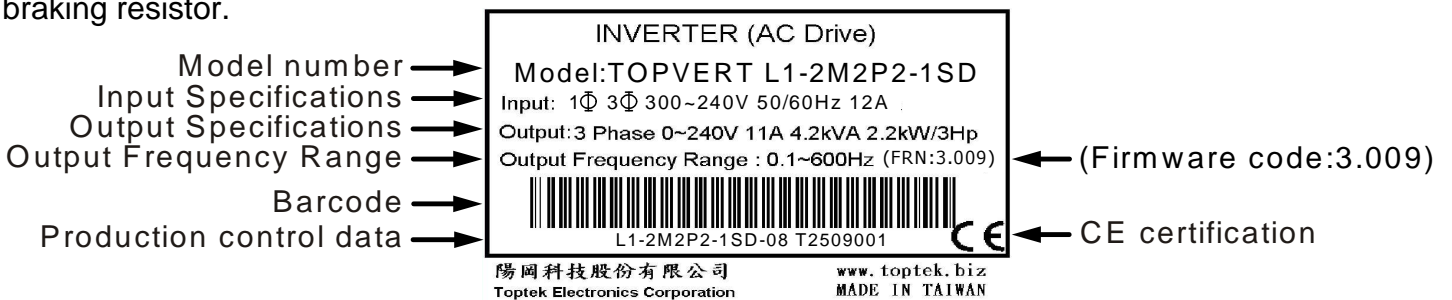

Model Explanation

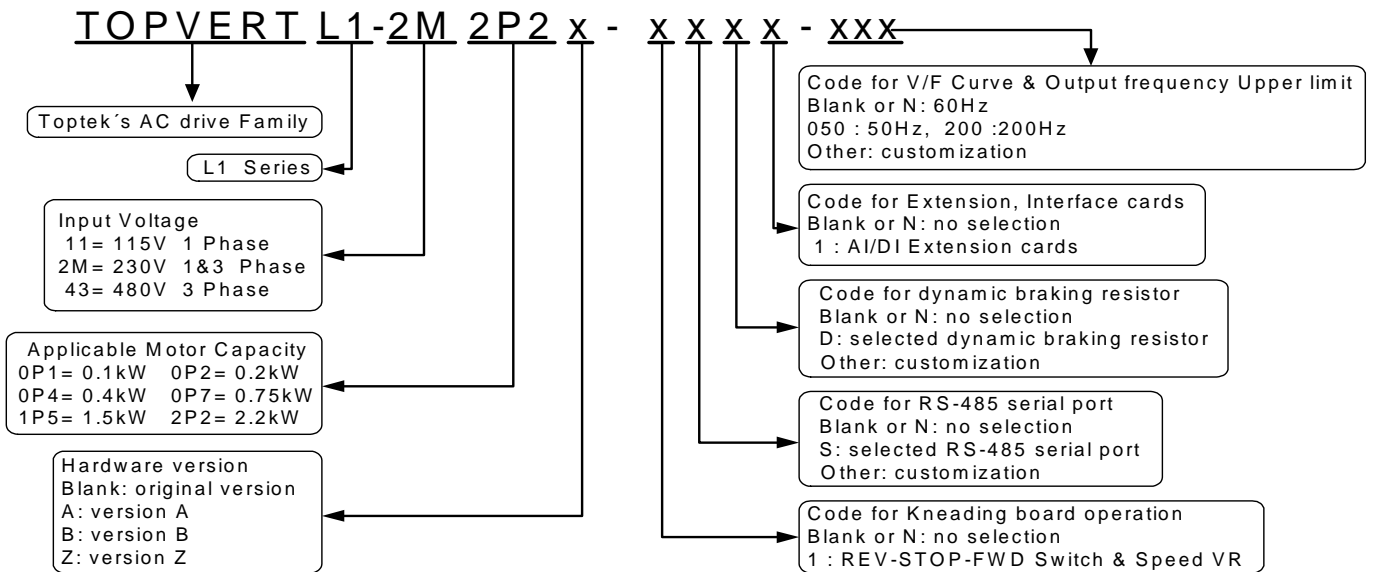

Explanation of Production control data

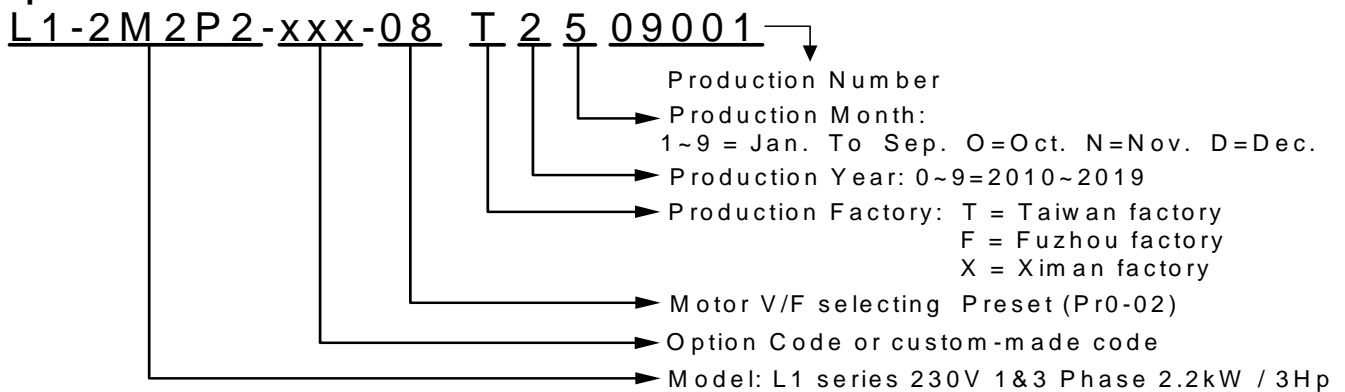

● Please contact the dealers immediately should any discrepancy occurred.

STANDARD SPECIFICATIONS

Series		TOPVERT L1 series Simple Mini micro drive	
Control Characteristics	Output frequency range	0.1 - 600Hz, Programmable	
	Overload endurance	150% of rated current for 1 minute/10 minutes, Ta <=40, 200% of rated current for 2 seconds	
	Maximum output voltage	Proportional to Input Voltage, 3-Phase output	
	Power factor/Efficiency	Power factor no lower than 0.95. Efficiency no lower than 95% at full load	
	Control system	SPWM (Sinusoidal Pulse Width Modulation) vector control, 2 control modes :V/F, SVC	
	Speed control range	V/F mode 20:1; SVC mode 120:1	
	Output frequency resolution	Analog input: 10Bit(1/1024), Digital input: 0.01Hz, Fly-Shuttle dial input: 0.01Hz	
	Output frequency accuracy	Analog input: Within ±0.2% of max. output frequency (25°C ±10°C). Digital input: Within 0.01% of set output frequency	
	PWM carrier Frequency	0.7 -18kHz, Adjustable (Some models are limited)	
	Torque characteristics	auto-torque boost, auto-slip compensation; starting torque can be 150% at 1.0Hz	
	Skip frequency	Setting range 0.00 -600Hz, Max. 6 points, skip width are adjustable	
	Accel/Decel time	0.1-60000 seconds (2 Independent settings for Accel/Decel Time)	
	Stall prevention	0 to 250% of Rated Current, independent adjustable both in acceleration and constant speed operation.	
	DC Braking	DC Braking both when start up and stop , Braking Current Level: 0 to 125% of rated output current. Braking time: 0 to 60 seconds. Braking Start-Point when stop: 0.1-600Hz	
	Dynamic braking	Braking torque Approx. 20%(10%E.D.)	
V/F Pattern	2 of adjustable Random V/F curve. Constant Torque curve & Reduced Torque curve are available.		
OPERATING Characteristics	Frequency Setting	Keypad	By an Encoder style Fly-Shuttle dial. (setting resolution 0.01Hz/0.1Hz/1Hz/10Hz adjustable)
		External Signal	0 ~ +10VDC((Input impedance 20kΩ), 4 ~20mA DC ((Input impedance 250Ω),Multi-Function Inputs 1 ~2 (15 Steps up/down), PLC run, RS-485 port MODBUS protocol
	Operation Setting	Keypad	Set by RUN and STOP. Switch-able between Keypad and External signal
		External Signal	2 wire control(FWD/STOP、REV/STOP、RUN/STOP、FWD/REV), 3 wire control, FWD, REV, MI1 to MI3 can be combined to offer various modes of operation, RS-485 serial interface MODBUS protocol
	Multi-Function Digital Input (DI) (2 terminals)	Multi-step selection 0 to 15, first to second accel/decel switches, accel/decel inhibit, Input the counter, Pause Stop, EF Input, Emergency Stop, auxiliary motor control is invalid, ACI/AVI speed command selection, Reset, PLC Run, Up/Down command, Parameter team selection...etc, up to 43 functions.	
	Multi-Function Output Indication (DO) (1 indication)	Include a form C relay contact, a form A relay contact and 2 Open collector output. They can be programmed to below indications: Drive Operating, Frequency Attained, zero speed, Base Block, Over torque, Fault Indication, Local/Remote indication, PLC Operation indication, and Auxiliary Motor Output, Drive ready for use, IGBT over-heat indication ...etc, up to 63 functions.	
	Multi-Function Analog Input (AI1)	AI1: 0 ~ +10VDC((Input impedance 20kΩ) /4 ~20mA DC ((Input impedance 250Ω). AI1 Input terminals can be programmed to 15 functions	
	Fault Indication	The output will be activated when faults occur (User may get 1 or up to 4 indications from below terminals:1 Relay contact point RA, RB, RC. or 2 Open-collector	
Communication function	RS-485 serial port, MODBUS protocol, ASCII & RTU. (Baud rate up to 125 k bps)		
Other Functions	PID feedback control, Flying start, Automatic voltage regulation (AVR), 2 accel./decel time selection , Auto-optimum accel./decel. Time, S-curves, External fault interlock, External fault reset, Auto Restart after fault, 16 Fault records, Automatic energy-saving, Upper/Lower limit, Programmable pulse output, Password protection, Pump and Fan process control, Sleep/Wakeup function , Auto-Tuning, By-Pass, Y-Delta control,. Bi-Directional Speed search, Reverse inhibit, Automatic torque boost & slip compensation, 16-step PLC run, 16 step preset speed, Coast or ramp to stop, Random V/F curve, Mechanical brake release control, IGBT/ Heatsink temperature display & Pre-warning, Quiet operation mode (No noise), User define Multi-function display, Over torque detection, Over current/voltage t stall prevention, Electronic Thermal Relay, Internal Counter, DC injection brake both in start and stop, Dynamic brake, Controlled cooling Fan, Removable keypad operator, Programmable Multi-Function DI,AI and Ry terminals.		
Intelligent Protection Functions	Self-testing, AC source Over Voltage, Phase loss, Over Voltage, Over Current, Under Voltage, Over Torque, External Fault, Motor over-load, IGBT Over-temperature, Heat-sink Over-temperature, Electronic thermal, Ground Fault, Output short circuit, Stall Prevention, Fuse protection, IGBT short circuit , Drive Over Load , DC bus capacitor life monitoring, Auto carrier frequency adjust according temperature, 16 Trip records, Run information of latest Fault such like DC-BUS voltage, Output voltage/Frequency/Current, Command frequency, IGBT temperature, Heat-sink temperature....etc.		
Digital Keypad(OPTION)	<p>Eight Function keys: Access Run, Stop, Reset/ Digit Shift, Display mode, Keypad Enable, Programming data and...etc.</p> <p>One Encoder style Fly-Shuttle dial: Sets the parameter number and changes the numerical data</p> <p>One 6 digits 7 segment display: Display the Setting frequency/actual operation frequency, Output current/Voltage, motor speed, Fault trip User defined unit(up to 88 type)...etc.</p> <p>Six LED Display for status indication: Display the Drive run/stop status, Forward/Reverse run status, Keypad enable, and Frequency command source.</p> <p>One RJ-45 connector: Removable Keypad, remote control distance up to 150 meters.</p>		
Environment	Certificate	Complies with CE (EN61800-3) standard	
	Temperature	Ambient: -10°C ~ +40°C/(-10°C ~ + 50°C) (Non-Condensing and not frozen). Storage: -20°C ~ +60°C	
	Humidity	Below 98% R.H. (Non-Condensing)	
	Vibration	Below 20Hz: 1G, above 20Hz: 0.6G	
	Installation Location	Altitude 1,000 m or lower, keep away from corrosive gasses, liquid and dust	

*TOPVERT all series are designed and manufactured base on CNS and IEC, IEEE, CE & UL standard.

1-Phase, 100 ~ 120VAC, 50/60 Hz (Tolerance Range: 90 ~ 132V, 47 ~ 63Hz) Output Voltage :200~240VAC											
Model	Applicable Motor (230V 4 P)		Rated Output				Source	Enclosure Construction			
TOPVERT L1-xxxxx	Power (kW)	Horse Power (Hp)	Capacity (kVA)	Current (A)	Voltage (V)	Frequency (Hz)	Current (A)	Cooling Methods	Protection Methods (IP/NEMA)	Net Weight (kg)	Frame Code
110P1					3- Phase, 0-240 (Max)	0.1- 600		Fan- cooled	IP 20 NEMA 1		L1-A
110P2	0.2	0.25	0.6	1.5			2.9				L1-B
110P4	0.4	0.5	1.2	3			5.7				L1-B
110P7	0.75	1	2	5			9.5				L1-C

1&3-Phase, 200 ~ 240VAC, 50/60 Hz (Tolerance Range: 180 ~ 264V,47 ~ 63Hz)											
Model	Applicable Motor (230V 4 P)		Rated Output				Source	Enclosure Construction			
TOPVERT L1-xxxxx	Power (kW)	Horse Power (Hp)	Capacity (kVA)	Current (A)	Voltage (V)	Frequency (Hz)	Current (A)	Cooling Methods	Protection Methods (IP/NEMA)	Net Weight (kg)	Frame Code
2M0P2	0.2	0.25	0.6	1.5	3- Phase, 0-240 (Max)	0.1-600	2.9	Fan- cooled	IP 20 NEMA 1	0.92	L1-B
2M0P4	0.4	0.5	1.2	3			5.7			0.92	
2M0P7	0.75	1	2	5			9.5			0.92	
2M1P5	1.5	2	3	7.5			14			1.10	
2M2P2	2.2	3	4.4	11			21				L1-C

3-Phase, 380 ~ 480VAC, 50/60 Hz (Tolerance Range: 342 ~ 528V,47 ~ 63Hz)											
Model	Applicable Motor (460V 4 P)		Rated Output				Source	Enclosure Construction			
TOPVERT L1-xxxxx	Power (kW)	Horse Power (Hp)	Capacity (kVA)	Current (A)	Voltage (V)	Frequency (Hz)	Current (A)	Cooling Methods	Protection Methods (IP/NEMA)	Net Weight (kg)	Frame Code
430P4	0.4	0.5	1.3	1.6	3- Phase, 0-460 (Max)	0.1-600	1.8	Fan- cooled	IP 20 NEMA 1	0.89	L1-B
430P7	0.75	1	2.4	3			3.3			0.89	
431P5	1.5	2	3.3	4.2			4.6			0.89	
432P2	2.2	3	4.8	6			6.6				L1-C

Basic Wiring Diagram

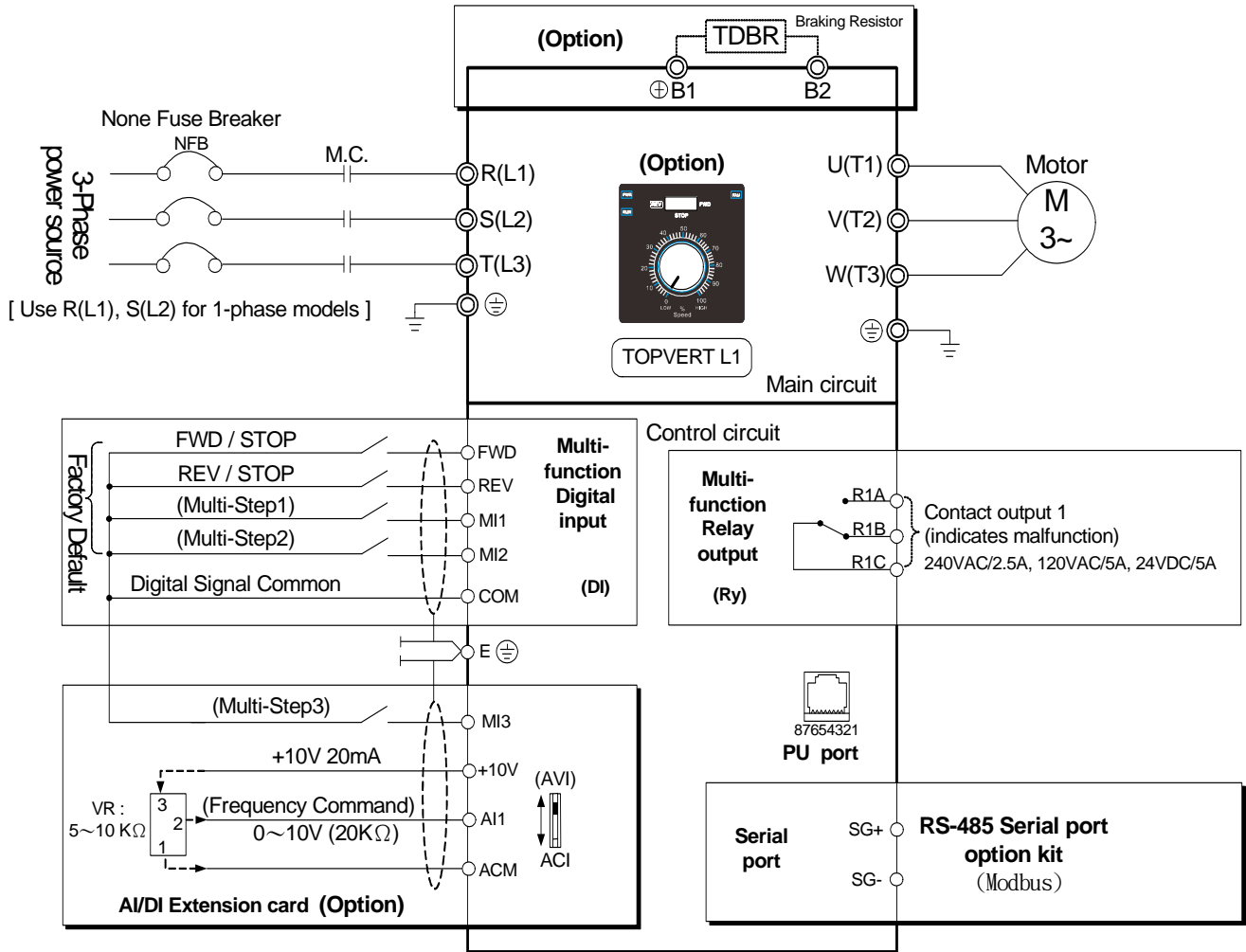

Remark: ⊙ → Main circuit ○ → Control circuit [] → Shielded leads & Cable () → Factory default □ → option

Input/Output pin assignment

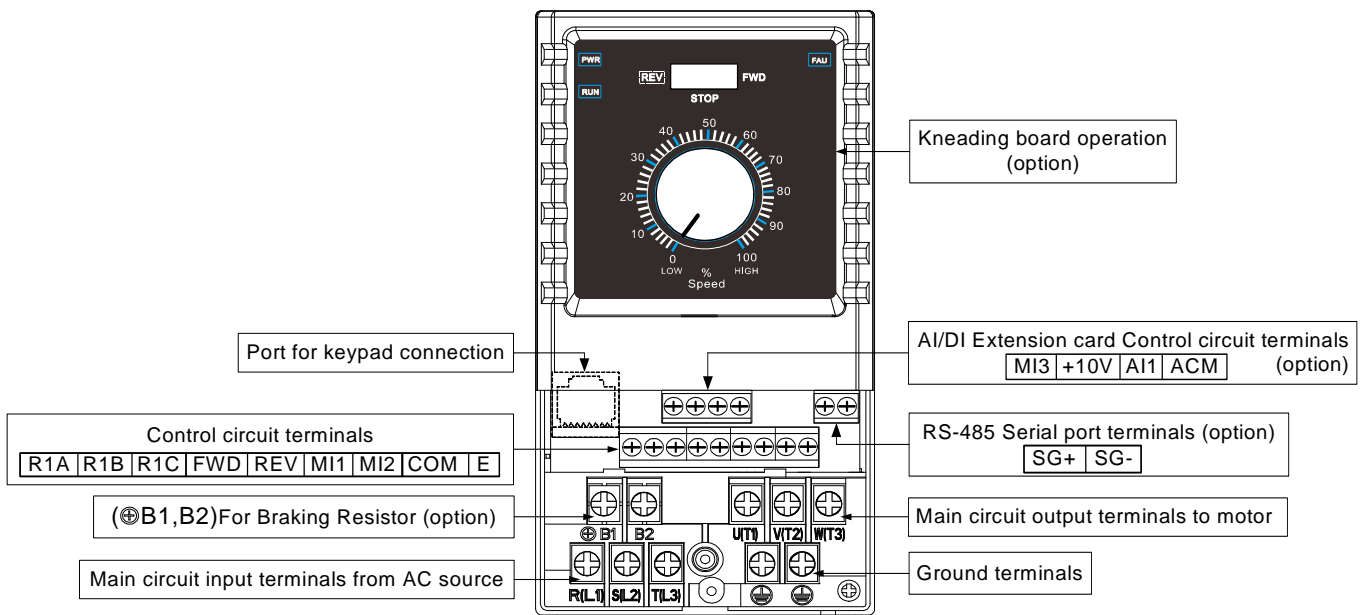

Main Circuit Terminal Explanations

Terminal Symbol	Content Explanation
R(L1),S(L2),T(L3)	AC source input terminals, to be connected to commercial power. Ensuring the power voltage and the maximum current possible supplied is meet the driver nameplate.
U(T1),V(T2),W(T3)	Drive output terminals for motor connections
⊕/B1, B2	Connections for Brake Resistor (optional) .
	Ground terminals, please have these terminals grounded following the third-type grounding of 230V series and the special grounding of 460V series within the electrician regulations

Control Terminal Explanations (Available when an I/O card is installed)

Terminal Symbols	Explanation on the Terminal Function	Factory Default
Digital inputs		
(Use the shielded twisted-pair cables to prevent operating faults)		
MI1	Multi-function digital input MI1 (3-wire STOP-designated terminal)	Pr2-01/ (multi-step speed command 1)
MI2	Multi-function digital input MI2	Pr2-02/ (multi-step speed command 2)
[MI3]	Multi-function digital input MI3	Pr2-03/ (multi-step speed command 3)
FWD	FWD RUN/STOP command	Pr2-00/(FWD RUN/STOP)
REV	REV RUN/STOP command	Pr2-00/(REV RUN/STOP)
Relay contact outputs		
Separate these control circuit wiring from wiring for other control terminals		
R1A	Multi-Function digital output 1 Relay 1 (Relay dry contact output) R1A-R1C :Relay 1 Normal open (a contact) R1B-R1C :Relay 1 Normal close (b contact)	Pr2-20 Resistive Load 5A(N.O.)/3A(N.C.) 240VAC 5A(N.O.)/3A(N.C.) 24VDC Inductive Load 1.5A(N.O.)/0.5A(N.C.) 240VAC 1.5A(N.O.)/0.5A(N.C.) 24VDC
R1B		
R1C		
Voltage source for digital signal and Frame Ground		
(Use the shielded twisted-pair cables to prevent operating faults)		
E	Connect to the shield net of shielded twisted-pair cables (Frame Ground)	
COM	Digital/Analog control signal - the common end	
Analog Inputs and outputs		
Analog input signals are easily affected by external noise. Use shielded twisted-pair cables for wiring and keep it as short as possible (<20m) with proper grounding. Basically the shield sheath should connect to the E terminal, but If the noise is inductive, connecting the shield to terminal ACM can bring improvement.		
[+10V]	+10V reference voltage source. Reference point is ACM.	Max.20mA/(+10V)
[AI1]	Multi-Function analog input 1 (voltage command or current command selectable) (When AI1 analog input selector switch to "V" can accept	Pr3-02/ (DC 0~10V / DC 4(0)~20mA corresponding to the maximum

	DC 0~10V voltage signal. when switch to "I" can accept DC 4(0)~20mA current signal.	operation frequency)
[ACM]	The reference point of analog inputs and outputs signal. The reference of reference voltage source. These terminals are isolated from DCM terminals	
serial port (Use the shielded twisted-pair cables to prevent operating faults)		
[SG+]	RS-485 serial port +	
[SG-]	RS-485 serial port -	

[]:Option

Description of the Digital Keypad



Multi-Function Operating Explanations

ITEM	Function
Multi-Function input (MI1 、 MI2)	Multi-Function setting: 1. Factory default 2.Customer assign
Running command (FWD 、 REV)	Forward/Stop 、 Reverse/Stop
Relay I/O(R1A 、 R1B 、 R1C)	Multi-Function setting: 1. Factory default 2.Customer assign
PU port(Key pad input)	Connecting with key pad (PU-01 AND PU-05)

Optional parts 1:
REV-STOP-FWD switch & speed adjustment



Multi-Function Operating Explanations

ITEM	Function
Multi-Function input (MI1 、 MI2)	Multi-Function setting: 1.Factory default 2.Customer assign
Running command (FWD 、 REV)	Forward/Stop 、 Reverse/Stop
Relay I/O(R1A 、 R1B 、 R1C)	Multi-Function setting: 1.Factory default 2.Customer assign
PU port(Key pad input)	Connecting with key pad (PU-01 AND PU-05)
REV-STOP-FWD switch	ON-OFF-ON 3 sections switch , REV-STOP-FWD 3 states for setting
Speed adjustment	Ajustment speed from 0%~100%.

Option parts 2:
AI/DI Expansion Card

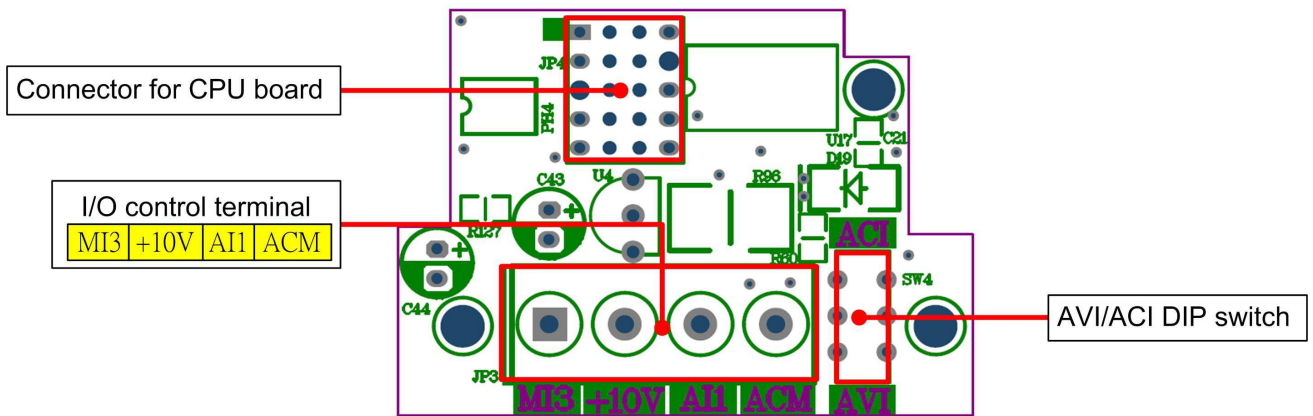

Multi-Function Operating Explanations

ITEM	Function
Multi-Function input (MI1、MI2、MI3)	Multi-Function setting: 1.Factory default 2.Customer assign
Running command (FWD、REV)	Forward/Stop、Reverse/Stop
Relay I/O(R1A、R1B、R1C)	Multi-Function setting: 1.Factory default 2.Customer assign
PU port(Key pad input)	Connecting with key pad (PU-01 AND PU-05)
External Analog Input(AI) AI1 Multi-Function terminal	Multi-Function setting: 1.Factory default 2.Customer assign
AI/DI Expansion Card	Selected circuit control or voltage control with DIP switch Set at "AVI",Input DC 0~10V to speed up/low ◦ Set at "ACI",Input DC 4(0)~20mA speed up & low ◦

Option parts 3:
RS-485 Serial port

Multi-Function Operating Explanations

ITEM	Function
Multi-Function input (MI1、MI2)	Multi-Function setting: 1.Factory default 2.Customer assign
Running command (FWD、REV)	Forward/Stop、Reverse/Stop
Relay I/O(R1A、R1B、R1C)	Multi-Function setting: 1.Factory default 2.Customer assign
PU port(Key pad input)	Connecting with key pad (PU-01 AND PU-05)
RS-485 Serial port terminal (SG+、SG-)	RS-485 serial port,It is used Modbus networks protocol, 2 pin easy plug in/out terminal. Also you can buy the TB/RJ45 adaptor from us when you need

Option parts 4 :

Digital Keypad PU-01

Digital Keypad PU-01 function descriptions

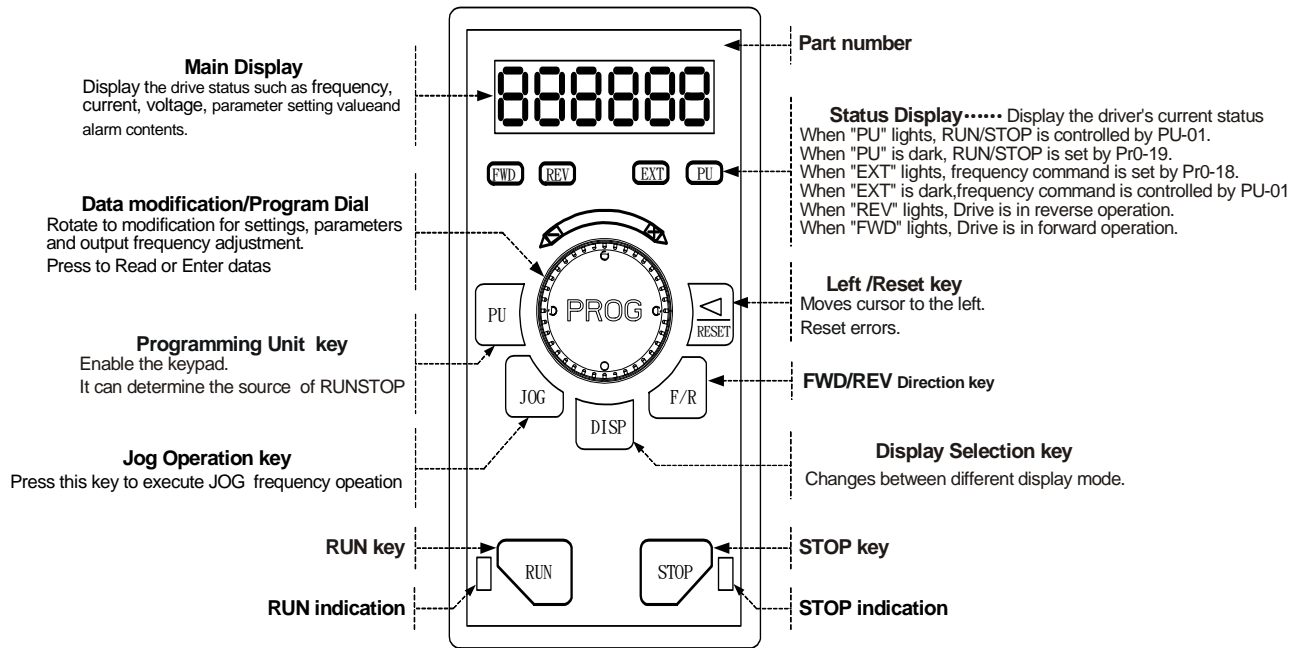

Digital Keypad PU-05



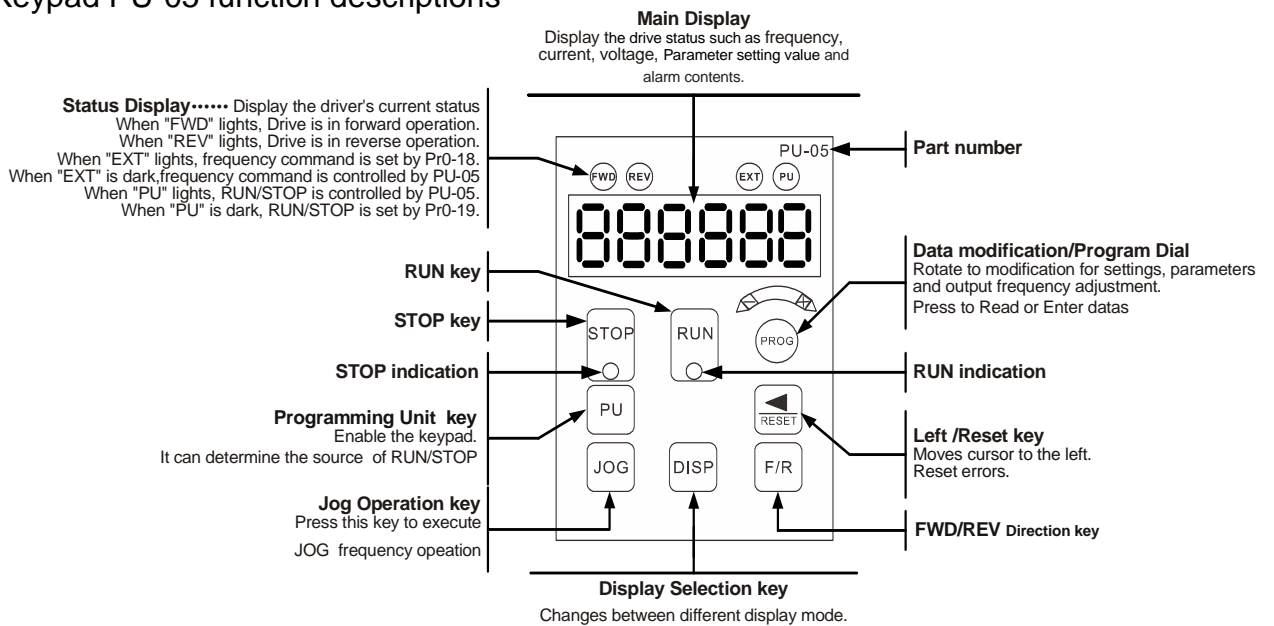







Digital Keypad PU-05 function descriptions



Multi-Function Operating Explanations

ITEM	Function
Multi-Function input (MI1 、 MI2)	Multi-Function setting: 1.Factory default 2.Customer assign
Running command (FWD 、 REV)	Forward/Stop 、 Reverse/Stop
Relay I/O(R1A 、 R1B 、 R1C)	Multi-Function setting: 1.Factory default 2.Customer assign
PU port(Key pad input)	Connecting with key pad (PU-01 AND PU-05)
Key pad-- PU-01/PU-05	Advance used 360 degree encoder switch. Easy and fast to adjustment the parameters. Our resolution minimum is 0.01Hz. resolved the resolution problem of VR.

Explanations of Display Messages

Messages Displayed	Descriptions
	Display master frequency command of the drive (Press the DISP key to read)
	Display actual operation frequency output to the motor from the drive (Press the DISP key to read)
	Display output current to motor (Press the DISP key to read)
	Display User-selected content on Pr0-07 (Press the DISP key to read)
	The specified parameter item (Rotate and press the  dial to modification, read and Enter) (Press  to display those parameters which data are different from factory default)
	Value of the parameter content (Rotate the  dial to modify for setting parameters)
	If the "End" message is displayed , for about 1 second, it is an indication that the data has been accepted and saved to the internal memory.

Operation Steps

Selecting display mode

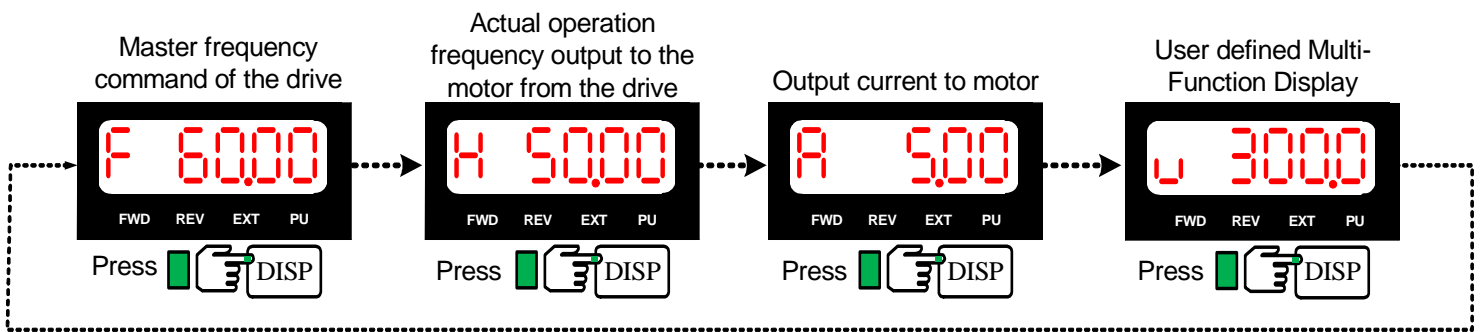

To scrolling between F page, H page, A page and U page by pressing the DISP key

Setting parameters

(For example, to set Pr0-07 = 2)

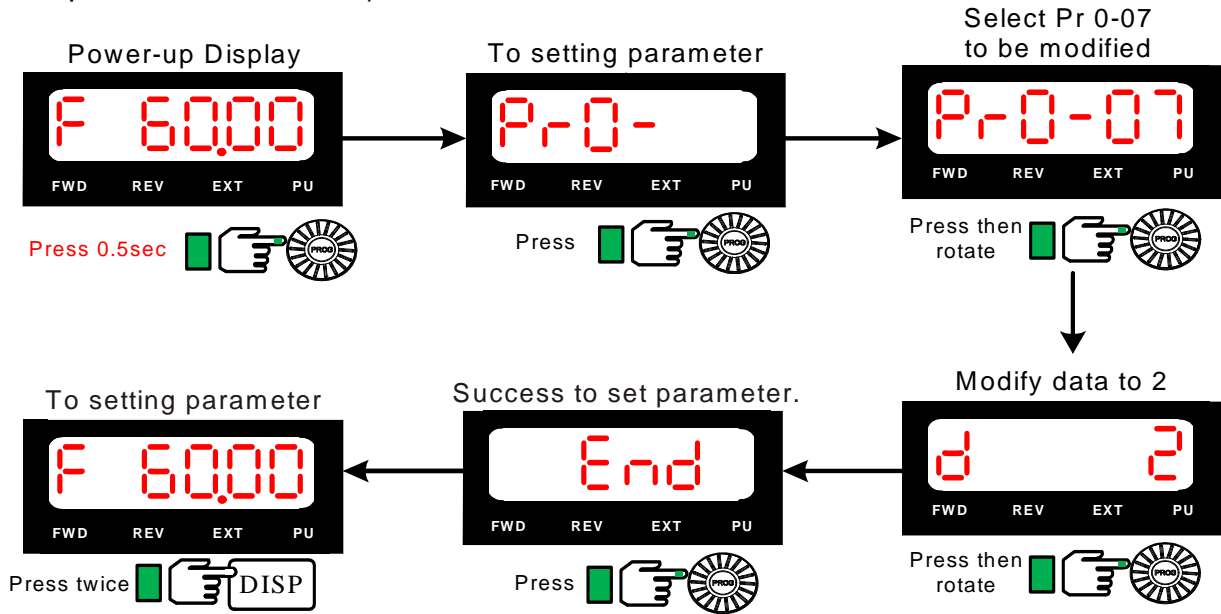

To run

(For example, to run 50 Hz from PU)

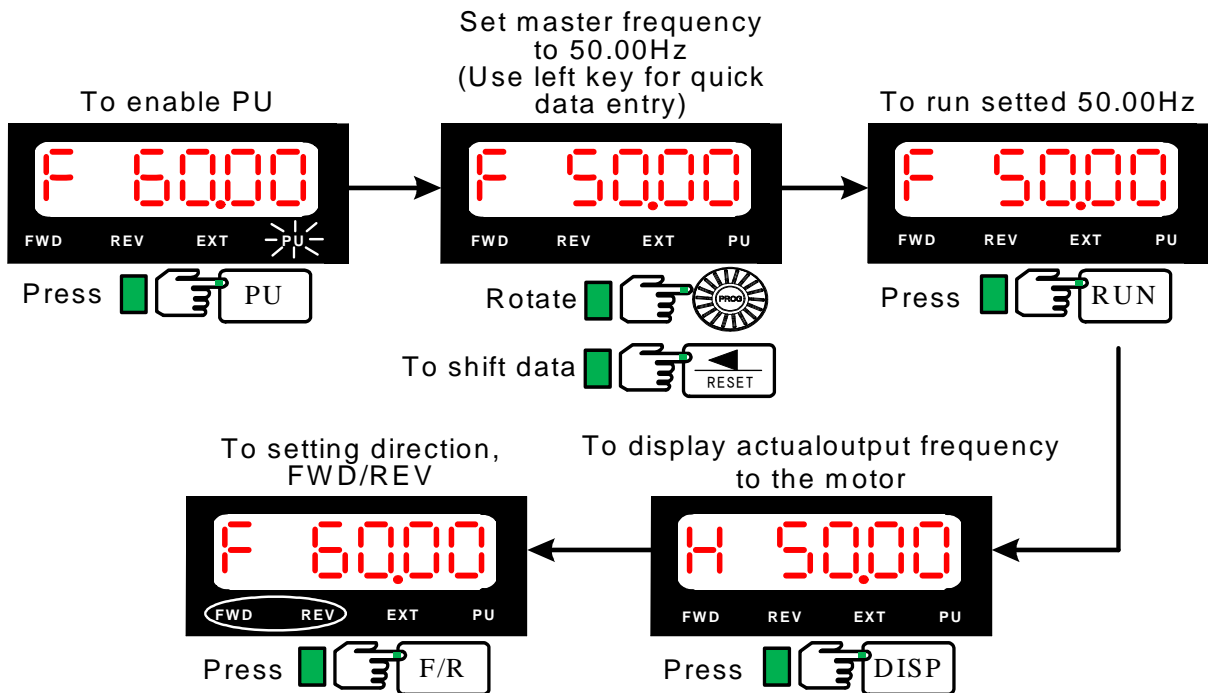

FUNCTIONS and PARAMETER SUMMARY

★=This parameter cannot be set during operation.	⊙: Available in Firmware Version 2.xx and after only.	⊙: Available in Firmware Version 3.xx and after only.
{ }Parameter no. in Firmware Version 1.xx	[]:optional	

Group 0: System parameters

Parameters	Functions	Settings	Factory Setting	User
★ Pr0-00	Model display	Display according to the model number	Read Only	
★ Pr0-01	Rated output current to motor	Display according to the model number	Read Only	
★ Pr0-02	Parameter Reset (Motor V/F selecting)	10: Parameter reset for 60Hz - 230/460V motor application	8	
		9: Parameter reset for 50Hz - 220/380V motor application		
		8: Parameter reset for 60Hz - 220/380V motor application		
		7: Parameter reset for 50Hz - 230/460V motor application		
		6: Parameter reset for 60Hz - 240/415V motor application		
		5: Parameter reset for 50Hz - 240/415V motor application		
Pr0-03	Password Input (The Key)	0~9999	0	
Pr0-04	Password set (The Lock)	0~9999	0	
Pr0-05	Parameter Locking Level	Bit 0 (bxxxx0)	b00000	
		Bit 1 (bxxx0x)		
		Bit 2 (bxx0xx)		
Pr0-06	Power on display selection	0: Frequency command value (F)	0	
		1: Actual output frequency (H)		
		2: Output current (A)		
		3: User defined contents on Pr0-07 (U)		
Pr0-07	Versatile display	0: Motor speed (RPM)	0	
		1: DC-Bus Voltage (Vdc)		
		2: Actual output voltage (Vac)		
		3: Output voltage command value (Vac)		
		4: PID feedback frequency value (Hz)		
		5: Running step no. of MSS run		
		6: Sleep time (Pr8-07)		
		7: Auto-Restart after Fault (Pr6-10)		
		8: PID frequency command value (Hz)		
		9: (Factory Reserved)		
		10: Output power factor angle (°)		
		11: Counter value		
		12: Over-Torque detection time 1 (Pr5-17)		
		13: (Factory Reserved)		
		14: Dwell Time at Accel. (Pr6-14)		
		15: Dwell Time at Decel. (Pr6-16)		
		16: DC Braking time in Start-up (Pr6-01)		
		17: DC Braking Time during stop (Pr6-02)		
18: Remain time of the executing MSS Run				

			19: (Factory Reserved) 20: (Factory Reserved) 21: Accumulated power-up Day (day) 22: Accumulated power-up time (hh:mm) 23: (Factory Reserved) 24: (Factory Reserved) 25: (Factory Reserved) 26: The signal of AI1 analog input 27: (Factory Reserved) 28: (Factory Reserved) 29: (Factory Reserved) 30~33: (Factory Reserved) 34: Over-Torque detection level 1 (Pr5-16) 35: Motor 1 Auto torque boost (Pr5-01) 36~37: (Factory Reserved) 38: Stall level while run in constant torque area (Pr5-12) 39~52: (Factory Reserved) 53: Output power (kW) 54: Output capacity (kVA) 55 : (Factory Reserved) 56: The temperature of IGBT module--TH1 (°C) 57: The temperature of environment or fin (TH2) (°C) 58: (Factory Reserved) 59: (Factory Reserved) 60: Drive overload accumulated time (OL) 61~63 : (Factory Reserved) 64: DC Bus voltage upon a fault (Vdc) 65: Output voltage upon a fault (Vac) 66: Output frequency upon a fault (Hz) 67: IGBT module temperature upon a fault (°C) ⊙ 68: Output current value upon a fault (Aac) 69 : Temperature of Fin or environment upon a fault (°C) ⊙ 70~86 : (Factory Reserved) 87: DC Bus ripple voltage (Vdc) ⊙ 88: (Factory Reserved) ⊙														
	Pr0-08	User-Defined coefficient K	0~39 (no use) 40~60000 (the corresponding value for Pr1-00-- the max. frequency).	0													
	Pr0-09	The decimal places	0~3 (0=Without d.p., 1= 1 digit d.p., 2=2 digit d.p., 3=3 digit d.p.)	0													
	Pr0-10	Firmware version	Read-only	x.xx													
	Pr0-11	EPROM store set	<table border="1"> <tr> <td rowspan="2">Bit 0 (bxxxx0)</td> <td>0: FWD/REV direction command will be store</td> </tr> <tr> <td>1: FWD/REV direction command not store</td> </tr> <tr> <td rowspan="2">Bit 1 (bxxx0x)</td> <td>0: Frequency command from PU will be store</td> </tr> <tr> <td>1: Frequency command from PU not store</td> </tr> <tr> <td rowspan="2">Bit 2 (bxx0xx)</td> <td>0: RS-485 frequency command will be store</td> </tr> <tr> <td>1: RS-485 frequency command not store</td> </tr> <tr> <td rowspan="2">Bit 3 (bx0xxx)</td> <td>0: Up/Down frequency command will be store</td> </tr> <tr> <td>1: Up/Down frequency command not store</td> </tr> </table>	Bit 0 (bxxxx0)	0: FWD/REV direction command will be store	1: FWD/REV direction command not store	Bit 1 (bxxx0x)	0: Frequency command from PU will be store	1: Frequency command from PU not store	Bit 2 (bxx0xx)	0: RS-485 frequency command will be store	1: RS-485 frequency command not store	Bit 3 (bx0xxx)	0: Up/Down frequency command will be store	1: Up/Down frequency command not store	b00000	
Bit 0 (bxxxx0)	0: FWD/REV direction command will be store																
	1: FWD/REV direction command not store																
Bit 1 (bxxx0x)	0: Frequency command from PU will be store																
	1: Frequency command from PU not store																
Bit 2 (bxx0xx)	0: RS-485 frequency command will be store																
	1: RS-485 frequency command not store																
Bit 3 (bx0xxx)	0: Up/Down frequency command will be store																
	1: Up/Down frequency command not store																

			Bit 4 (b0xxxx)	0: Changed parameter will be store 1: Changed parameter not store		
	Pr0-12	Auto Accelerate/ Decelerate		0: Linear Acc, linear Dec. 1: Auto Acc, linear Dec. 2: Linear Acc, auto Dec. 3: Auto Acc, auto Dec. 4: Linear Acc,/Dec., auto to prevent stall.	0	
★	Pr0-13	Accelerate/ Decelerate time unit		0: 0.01 Second 1: 0.1 Second 2: 1 Second	0	
	Pr0-14	PWM Carrier frequency upper bound		0=0.7kHz 1~18kHz	10	
	Pr0-15	PWM Carrier frequency lower bound		0=0.7kHz 1~18kHz	10	
	Pr0-16	Automatic Voltage Regulation (AVR)		0: Enable Automatic Voltage Regulation 1: Disable Automatic Voltage Regulation 2: Disable Automatic Voltage Regulation while in cancel	0	
	Pr0-17	Automatic Energy-Saving Operation (AESO) and others	Bit 0 (bxxxx0)	0: Disable Automatic Energy-Saving Operate 1: Enable Automatic Energy-Saving Operate	b00000	
			Bit 1 (bxxx0x)	0: Allow output voltage over source voltage 1: Maximum output voltage equals to source voltage		
			Bit 2 (bxx0xx)	0: For constant torque load application. 1: For variable torque load application.		
			Bit 3 (bx0xxx)	0: Regen-torque no slip compensation 1: Regen-torque with slip compensation		
			Bit 4 (b0xxxx)	0: Low noise mode operation 1: Quiet mode operation		
	Pr0-18	Source of the frequency command		0: From PU 1: From RS485 communication port 2: From external analog signal 3: From external Up/Down terminals 4: (Factory Reserved)	0	◎
	Pr0-19	Source of the operation command		0: From RS485 communication port or PU 1: From external terminals or PU 2: From PU 3: From external terminals	0	
	Pr0-20	Stop/ Run/safety lockout	Bit 0 (bxxxx0)	0: Ramp to stop 1: Coast to stop	b00000	
			Bit 1 (bxxx0x)	0: Terminal command not run after reset 1: Terminal command restart after reset		
			Bit 2 (bxx0xx)	0: Line start Lockout is enabled 1: Line start Lockout is disabled		
			Bit 3 (bx0xxx)	0: FWD/REV go through zero point 1: FWD/REV go not through zero point		
			Bit 4 (b0xxxx)	0: Linear Accel/Decel at high speed zone 1: S-curve Accel/Decel at high speed zone		
	Pr0-21	Direction limit		0: Enable Forward/Reverse operation 1: Disable Reverse operation 2: Disabled Forward operation	0	

	Pr0-22	Waiting time to restart after stop	0.00~60.00sec		0.00	
	Pr0-23	Cooling fan control & PID direction	Bit 0 (bxxxx0)	0: Fan on while power on 1: Fan on while run command effect	b00000	
			Bit 1 (bxxx0x)	(Factory Reserved)		
			Bit 2 (bxx0xx)	(Factory Reserved)		
			Bit 3 (bx0xxx)	0: PID reverse operation allow 1: PID reverse operation not allow		
			Bit 4 (b0xxxx)	(Factory Reserved)		
	Pr0-24	Resolution of dial	0=0.01 Hz		1	
			1=0.10Hz			
			2=1.00Hz			
			3=10.00 Hz			
★ ◎	Pr0-25	Parameter select	0: Team A		0	
			1: Team B			
			2: (Factory Reserved)			

Group 1: Basic parameters

	Parameters	Functions	Settings		Factory Setting	User
★	Pr1-00	Maximum operation frequency	3.00~600.00Hz		60.00/50.00	
★	Pr1-01	1st Frequency 1 (Fbase 1) (Base frequency 1)	0.00~600.00 Hz		60.00/50.00	
	Pr1-02	1st Voltage 1 (Vbase 1) (Motor rated voltage 1)	230V models: 0.0~255.0V	460V models: 0.0~510.0V	230V:230.0 460V:460.0	
★	Pr1-03	2nd Frequency 1 (Fmid 1) (Middle frequency 1)	0.00~600.00 Hz		0.50	
	Pr1-04	2nd Voltage 1 (Vmid 1) (Middle voltage 1)	230V models: 0.0~255.0V	460V models: 0.0~510.0V	230V:5.0 460V:10.0	
★	Pr1-05	3rd Frequency 1 (Flow 1) (Low-point frequency 1)	0.00~600.00 Hz		0.50	
	Pr1-06	3rd Voltage 1 (Vlow 1) (Low-point voltage 1)	230V models: 0.0~255.0	460V models: 0.0~510.0V	230V:5.0 460V:10.0	
	Pr1-07	0Hz Voltage 1 (V0Hz 1) (Output voltage at 0Hz)	230V models: 0.0~25.5	460V models: 0.0~51.0V	0.0	
	Pr1-08	Start-up frequency	0.00~600.00 Hz		0.50	
	Pr1-09	Output frequency Upper limit	0.0~150.0% of Maximum operation frequency (Pr1-00)		110.0	
	Pr1-10	Output Frequency Lower limit	0.0~100.0% of Maximum operation frequency (Pr1-00)		0.0	
	Pr1-11	1 st Acceleration time	0.00~60000 Sec		10.00/60.00	
	Pr1-12	1 st Deceleration time	0.00~60000 Sec		10.00/60.00	
	Pr1-13	2 nd Acceleration time	0.00~60000 Sec		10.00/60.00	
	Pr1-14	2 nd Deceleration time	0.00~60000 Sec		10.00/60.00	
	Pr1-15	(Factory Reserved)	(Factory Reserved)			
	Pr1-16	(Factory Reserved)	(Factory Reserved)			
	Pr1-17	(Factory Reserved)	(Factory Reserved)			

	Pr1-18	1st/2nd Acceleration/Deceleration Switching frequency	0.00~600.00 Hz		0.000	
	Pr1-19	S-Acc. departure time when accelerate	0.00~12000 Sec		0.00	
	Pr1-20	S-Acc. arrival time when accelerate	0.00~12000 Sec		0.00	
	Pr1-21	S-Dec. departure time when decelerate	0.00~12000 Sec		0.00	
	Pr1-22	S-Dec. arrival time when decelerate	0.00~12000 Sec		0.00	
	Pr1-23 {Pr1-29}	Offset voltage while decelerate	230V models: -50.0~50.0 V	460V models: -100.0~100.0 V	0.00	
★	Pr1-24 {Pr1-23}	Skip Frequency 1 upper limit	0.00~600.00Hz		0.00	
★	Pr1-25 {Pr1-24}	Skip Frequency 1 lower limit	0.00~600.00Hz		0.00	
★	Pr1-26 {Pr1-25}	Skip Frequency 2 upper limit	0.00~600.00Hz		0.00	
★	Pr1-27 {Pr1-26}	Skip Frequency 2 lower limit	0.00~600.00Hz		0.00	
★	Pr1-28 {Pr1-27}	Skip Frequency 3 upper limit	0.00~600.00Hz		0.00	
★	Pr1-29 {Pr1-28}	Skip Frequency 3 lower limit	0.00~600.00Hz		0.00	
★ ◎	Pr1-30	Skip Frequency 4 upper limit	0.00~600.00 Hz)		0.00	
★ ◎	Pr1-31	Skip Frequency 4 lower limit	0.00~600.00 Hz		0.00	
★ ◎	Pr1-32	Skip Frequency 5 upper limit	0.00~600.00 Hz		0.00	
★ ◎	Pr1-33	Skip Frequency 5 lower limit	0.00~600.00 Hz		0.00	
★ ◎	Pr1-34	Skip Frequency 6 upper limit	0.00~600.00 Hz		0.00	
★ ◎	Pr1-35	Skip Frequency 6 lower limit	0.00~600.00 Hz		0.00	
★ ◎	Pr1-36	1st Frequency 2 (Fbase 2) (Base frequency 2)	0.00~600.00 Hz		60.00/50.00	
◎	Pr1-37	1st Voltage 2 (Vbase 2) (Motor rated voltage 2)	230V models: 0.0~255.0V	460V models: 0.0~510.0V	230V:230 460V:460	
★ ◎	Pr1-38	2nd Frequency 2 (Fmid 2) (Middle frequency 2)	0.00~600.00 Hz		0.50	
★ ◎	Pr1-39	2nd Voltage 2 (Vmid 2) (Middle voltage 2)	230V models: 0.0~255.0V	460V models: 0.0~510.0V	230V:5.0 460V:10.0	
★ ◎	Pr1-40	3rd Frequency 2 (Flow 2) (Low-point frequency 2)	0.00~600.00 Hz		0.50	
★ ◎	Pr1-41	3rd Voltage 2 (Vlow 2) (Low-point voltage 2)	230V model: 0.0~255.0V	460V model: 0.0~510.0V	230V:5.0 460V:10.0	
★ ◎	Pr1-42	0Hz Voltage 2 (V0Hz 2) (Output voltage at 0Hz)	230V models: 0.0~25.5	460V models: 0.0~51.0V	0.0	

Group 2: Digital Input/Output parameters

	Parameters	Functions	Settings	Factory Setting	User								
★	Pr2-00	External operation	0: 2-wire mode 1- FWD/STOP, REV/STOP 1: 2-wire mode 2- RUN/STOP, REV/FWD 2: 3-wire mode -RUN,STOP, FWD/REV	0									
★	Pr2-01	Multi-Function Digital input MI1	0: No definition	1									
★	Pr2-02	Multi-Function Digital input MI2	1: Multi-step speed command 1	2									
★	Pr2-03	(Factory Reserved)	2: Multi-step speed command 2	3									
★	Pr2-04	(Factory Reserved)	3: Multi-step speed command 3	4									
★	Pr2-05	(Factory Reserved)	4: Multi-step speed command 4	5									
★	Pr2-06	(Factory Reserved)	5: External Reset 6: Clear counter 7: 1st and 2nd acceleration/ deceleration time select 8: Acceleration/deceleration inhibit 9: Force the frequency command from AI1 10: (Factory Reserved) 11: (Factory Reserved) 12: Emergency Ramp to stop 13: Disable PID function 14: External fault input (EF) 15: B.B. traces from the bottom upward 16: B.B. traces from the top downward 17: Force operation command to external 18: Cancel the auto acceleration/ deceleration function 19: (Factory Reserved) 20: (Factory Reserved) 21: (Factory Reserved) 22: Cancel PLC Run 23: Pause PLC Run 24: Up command 25: Down command 26: Zero speed is replaced by DC braking 27: Pause 28: Disable dwell function 29: Disable traverse function 30: Disable Speed search during start-up 31: Disable EEPROM write function 32: Counter Trigger input (MI2 only) 33~41: (Factory Reserved) 42: Motor Select <input type="radio"/> 43: Confirm signal of Motor selection <input type="radio"/> 44: Disable reverse operation <input type="radio"/> 45: Disabled forward operation <input type="radio"/>	14									
	Pr2-07	UP/DOWN command mode	<table border="1"> <tr> <td>Bit 0 (bxxxx0)</td> <td>0: Up command-Accel by the Acc. time 1: Up command-Accel by Pr2-08 setting</td> </tr> <tr> <td>Bit 1 (bxxx0x)</td> <td>0: Down Command-Decel by the Dec. time 1: Down Command-Decel by Pr2-08 setting</td> </tr> <tr> <td>Bit 2 (bxx0xx)</td> <td>(Factory Reserved)</td> </tr> <tr> <td>Bit 3 (bx0xxx)</td> <td>0: FWD/REV terminals act by edge trigger</td> </tr> </table>	Bit 0 (bxxxx0)	0: Up command-Accel by the Acc. time 1: Up command-Accel by Pr2-08 setting	Bit 1 (bxxx0x)	0: Down Command-Decel by the Dec. time 1: Down Command-Decel by Pr2-08 setting	Bit 2 (bxx0xx)	(Factory Reserved)	Bit 3 (bx0xxx)	0: FWD/REV terminals act by edge trigger	b00000	
Bit 0 (bxxxx0)	0: Up command-Accel by the Acc. time 1: Up command-Accel by Pr2-08 setting												
Bit 1 (bxxx0x)	0: Down Command-Decel by the Dec. time 1: Down Command-Decel by Pr2-08 setting												
Bit 2 (bxx0xx)	(Factory Reserved)												
Bit 3 (bx0xxx)	0: FWD/REV terminals act by edge trigger												

			1: FWD/REV terminals act by level trigger		
			Bit 4 (b0xxxx)	(Factory Reserved)	
	Pr2-08	UP/DOWN command rate			0.01
	Pr2-09	Digital Input terminal debounce time	0.001~30.000 Sec		0.005
	Pr2-10	Polarity of Digital Input terminals	00000~007FF	h00000	
			(0=Close circuit enable 1=Open circuit enable)		
	Pr2-11	Target count value	0~65500		0
	Pr2-12	Pre warn count value	0~65500		0
	Pr2-13	Digital pulse output gain	1~20		1
	Pr2-14	Pre-set arrival frequency 1	0.00~600.00 Hz		60.00/ 50.00
	Pr2-15	Pre-set arrival frequency 1 bandwidth	0.00~600.00 Hz		2.00
	Pr2-16	Pre-set arrival frequency 2	0.00~600.00 Hz		60.00/ 50.00
	Pr2-17	Pre-set arrival frequency 2 bandwidth	0.00~600.00 Hz		2.00
	Pr2-18	Polarity of Digital output terminals	00000~0003F		h00000
◎	Pr2-19	Delay time of Digital output terminals	0.000~60.000 Sec		0.003
	Pr2-20 {Pr2-19}	Multi-Function Digital output 1- Relay 1	0: No definition		11
	Pr2-21 {Pr2-20}	(Factory Reserved)	1: Drive in run		1
	Pr2-22 {Pr2-21}	(Factory Reserved)	2: Master frequency attained 1 (Both Forward and Reverse)		5
	Pr2-23 {Pr2-22}	(Factory Reserved)	3: Master frequency attained 2 (Both Forward and Reverse)		
◎	Pr2-24	(Factory Reserved)	4: Pre-set speed attained 1 (Both Forward and Reverse)		9
◎	Pr2-25	(Factory Reserved)	5: Pre-set speed attained 1 (Forward only)		0
			6: Pre-set speed attained 2 (Both Forward and Reverse)		0
			7 : Pre-set speed attained 2 (Forward only)		
			8: Drive in decel		
			9: Drive ready for operate		
			10: Low voltage alarm (LU, LUr)		
			11: Fault Indication		
			12: Base block (B.B.) Indication		
			13: Zero Speed (including shutdown)		
			14: Zero speed (while in run)		
			15: Terminal count value attained		
			16: Pre warn count value attained		
			17: PLC Run running		
			18: PLC Run paused		
			19: A step of PLC Run completed		
			20: PLC Run completed		
			21: OH1 pre-warning indication		
			22: Dwell Accel/Decel in execution		
			23: External operation mode indication		
			24: Over-torque 1 (ot1)		
			25: (Factory Reserved)		
			26: Software brake output (MO1 only)		
			27: Auxiliary Motor no. 1		

			28: Auxiliary Motor no. 2		
			29: Auxiliary Motor no. 3		
			30: Over-torque 2 (ot2)	⊙	
			31: OH2 pre-warning indication	⊙	
			32: Motor selection output (Pr5-49)	⊙	
			33~47: (Factory Reserved)		
			48: Master speed executing		
			49: PLC Run step 1 executing		
			50: PLC Run step 2 executing		
			51: PLC Run step 3 executing		
			52: PLC Run step 4 executing		
			53: PLC Run step 5 executing		
			54: PLC Run step 6 executing		
			55: PLC Run step 7 executing		
			56: PLC Run step 8 executing		
			57: PLC Run step 9 executing		
			58: PLC Run step 10 executing		
			59: PLC Run step 11 executing		
			60: PLC Run step 12 executing		
			61: PLC Run step 13 executing		
			62: PLC Run step 14 executing		
			63: PLC Run step 15 executing		
			64~79: (Factory Reserved)		
⊙	Pr2-26	(Factory Reserved)			
⊙	Pr2-27	(Factory Reserved)	(Factory Reserved)	0	
⊙	Pr2-28	(Factory Reserved)			

Group 3: Analog Input/Output parameters

Parameters	Functions	Settings	Factory Setting	User
Pr3-00	Addition Function of the Analog Inputs	0: Enable addition function	0	
		1: Disable addition function		
Pr3-01	Analog input noise filter time	0.00~2.00 sec	0.10	
	AI1 Analog Input	0: No functions	1	
		1: Frequency command		
		2: To adjust 1st Acceleration/deceleration time (same as Pr1-11, Pr1-12)		
		3: Over Current stall prevention level during constant speed run on the constant torque region (same as Pr5-12)		
		4: Over Current stall prevention level during accel on the constant torque region (same as Pr5-10)		
		5: Over-Torque detection level 1 (ot1) (same as Pr5-16)		
		6: Motor 1 Torque boost level (same as Pr5-01)		
		7: Auxiliary command when main frequency command is AI1 only		
		8: (Factory Reserved)		
		9: (Factory Reserved)		
		10: Auxiliary command of master frequency command		
		11: PID feedback signal		
		12: PID offset signal (same as Pr7-05)		
		13: DC Braking current level (same as Pr6-00)		
		14: Voltage adjusts during run. (AI1 Pr3-02 only)		
15: External temperatures signal				

			16: Torque adjust		
	Pr3-03	AI1 analog Input bias	-10.00~10.00V	0.00	
	Pr3-04	AI1 analog Input gain	-500.0~+500.0%	100.0	
	Pr3-05	AI1 analog Input bias mode	0: Zero bias	0	
			1: Value lower than bias = bias		
			2: Value higher than bias = bias		
			3: The absolute value of the bias voltage while serving as the center		

Group 4: Multi-Step Speed and Process Logic Control operation parameters

Parameters	Functions	Settings	Factory Setting	User
Pr4-00	The 1st step speed of PLC Run or MSS Run	0.00~600.00 Hz	0.00	
Pr4-01	The 2nd step speed of PLC Run or MSS Run	0.00~600.00 Hz	0.00	
Pr4-02	The 3rd step speed of PLC Run or MSS Run	0.00~600.00 Hz	0.00	
Pr4-03	The 4th step speed of PLC Run or MSS Run	0.00~600.00 Hz	0.00	
Pr4-04	The 5th step speed of PLC Run or MSS Run	0.00~600.00 Hz	0.00	
Pr4-05	The 6th step speed of PLC Run or MSS Run	0.00~600.00 Hz	0.00	
Pr4-06	The 7th step speed of PLC Run or MSS Run	0.00~600.00 Hz	0.00	
Pr4-07	The 8th step speed of PLC Run or MSS Run	0.00~600.00 Hz	0.00	
Pr4-08	The 9th step speed of PLC Run or MSS Run	0.00~600.00 Hz	0.00	
Pr4-09	The 10th step speed of PLC Run or MSS Run	0.00~600.00 Hz	0.00	
Pr4-10	The 11th step speed of PLC Run or MSS Run	0.00~600.00 Hz	0.00	
Pr4-11	The 12th step speed of PLC Run or MSS Run	0.00~600.00 Hz	0.00	
Pr4-12	The 13th step speed of PLC Run or MSS Run	0.00~600.00 Hz	0.00	
Pr4-13	The 14th step speed of PLC Run or MSS Run	0.00~600.00 Hz	0.00	
Pr4-14	The 15th step speed of PLC Run or MSS Run	0.00~600.00 Hz	0.00	
Pr4-15	The duration of master speed	0.0~65500 Sec	0.0	
Pr4-16	The 1st step duration of PLC Run or MSS Run	0.0~65500 Sec	0.0	
Pr4-17	The 2nd step duration of PLC Run or MSS Run	0.0~65500 Sec	0.0	
Pr4-18	The 3rd Step duration of PLC Run or MSS Run	0.0~65500 Sec	0.0	
Pr4-19	The 4th Step duration of PLC Run or MSS Run	0.0~65500 Sec	0.0	
Pr4-20	The 5th Step duration of PLC Run or MSS Run	0.0~65500 Sec	0.0	
Pr4-21	The 6th Step duration of PLC Run or MSS Run	0.0~65500 Sec	0.0	
Pr4-22	The 7th Step duration of PLC Run or MSS Run	0.0~65500 Sec	0.0	
Pr4-23	The 8th Step duration of PLC Run or MSS Run	0.0~65500 Sec	0.0	
Pr4-24	The 9th Step duration of PLC Run or MSS Run	0.0~65500 Sec	0.0	

Pr4-25	The 10th Step duration of PLC Run or MSS Run	0.0~65500 Sec	0.0	
Pr4-26	The 11th Step duration of PLC Run or MSS Run	0.0~65500 Sec	0.0	
Pr4-27	The 12th Step duration of PLC Run or MSS Run	0.0~65500 Sec	0.0	
Pr4-28	The 13th Step duration of PLC Run or MSS Run	0.0~65500 Sec	0.0	
Pr4-29	The 14th Step duration of PLC Run or MSS Run	0.0~65500 Sec	0.0	
Pr4-30	The 15th Step duration of PLC Run or MSS Run	0.0~65500 Sec	0.0	
Pr4-31	The PLC Run or MSS Run time multiplier	1~10	1	
Pr4-32	The PLC Run or MSS Run operation direction of each step	00000~07FFF (0 : forward ; 1 : reverse)	h00000	
Pr4-33	PLC Run operation mode	Bit 0 (bxxxx0)	0: Direction determined by Pr4-32 1: Direction determined by the master speed	b01000
		Bit 1 (bxxx0x)	0: Without zero intervals (Continue mode) 1: With zero intervals (Stop mode)	
		Bit 2 (bxx0xx)	0: Run zero speed when PLC Run Paused 1: Run original programmed step speed when PLC Run Paused	
		Bit 3 (bx0xxx)	0: Re-Execute PLC Run from step 0 after recover from power interruption 1: Continue Execute PLC Run from the point which power interrupted after recover from power interruption	
Pr4-34	PLC Run operation cycle	0~60000 : 0~60000 cycle 0= PLC Run disabled 60001: Continuously execute recurring cycles	0	
Pr4-35	What to do after PLC Run completed	0~15 : step speed (0=master speed) 16 : stop	16	
Pr4-36	Multi-Step Speed Run (MSS RUN) operation mode	Bit 0 (bxxxx0)	0: Direction determined by Pr4-32 1: Direction determined by the master speed	b00001
		Bit 1 (bxxx0x)	0: Duration of MSS Run determined by Mix terminals. 1: Duration of MSS Run determined by Pr4-15~Pr4-30 setting.	
		Bit 2 (bxx0xx)	0: Without zero intervals (Continue mode) 1: With zero intervals (Stop mode)	
		Bit 3 (bx0xxx)	0: PID offset ineffective 1: MSS Run + PID offset effective	

Group 5: Motor parameters and protection parameters

Parameters	Functions	Settings	Factory Setting	User
★ Pr5-00	Full-Load Current of Motor 1	Amp (10~120% of drive's rated current)	xxxA (100%)	
Pr5-01	Auto Torque Compensation of Motor 1	0.0~25.0%	0.0	
Pr5-02	Slip Compensation of Motor 1	0~20 RPM	0	
Pr5-03	Number of Motor Poles 1	2~20	4	
Pr5-04	Rotor Resistance R1 of Motor 1	0.000~65.535 Ω	0	

★	Pr5-05	Auto-tuning & control mode selection	0: No function		0	
			1: To execute auto-tuning and switch to Sensor less vector control mode			
			2: Reset to V/F control mode			
★	Pr5-06	Low Voltage Level I	230V models: 160~220VAC	460V models: 320~440VAC	230V:180 460V:360	
★	Pr5-07	Over-Voltage Stall Prevention Level	230V models: 320~500VDC	460V models: 640~1000VDC	230V:380 460V:760	
	Pr5-08	Software Braking Level	230V models: 320~500VDC	460V models: 640~1000VDC	230V:373 460V:746	
	Pr5-09	Phase-Loss Protection	0: Warn and keep operation (below 50%)		0	
			1: Warn and ramp to stop			
			2: Warn and coast to stop			
	Pr5-10	Over- Current Stall Prevention level during accel on the constant torque region	Amp (10~250% of drive's rated current)		A(170%)	
	Pr5-11	Over- Current Stall Prevention low-limit level during accel on the constant power region	Amp (0~250% of drive's rated current)		A(120%)	
	Pr5-12	Over-Current Stall Prevention level during constant speed on the constant torque region Operation	Amp (10~250% of drive's rated current)		A(170%)	
	Pr5-13	Over- Current Stall Prevention low-limit level during constant speed run on the constant power region	Amp (0~250% of drive's rated current)		A(120%)	
	Pr5-14	Over-Current Deceleration Time during Operation	0.050~600.00 Sec		3.00	
	Pr5-15	Over-Torque Detection Selection 1 (ot1)	0 : Disabled		0	
			1 : Over-torque detection during constant speed operation, stop operation after detection.			
			2 : Over-torque detection during constant speed operation, continue to operate after detection.			
			3 : Over-torque detection during operation, stop operation after detection			
			4 : Over-torque detection during operation, continue operation after detection.			
	Pr5-16	Over-Torque Detection Level 1 (ot1)	Amp(10~250% of drive's rated current)		A (150%)	
	Pr5-17	Over-Torque Detection Time 1 (ot1)	0.0~60.0 Sec		0.1	
	Pr 5-18	Motor 1- Electronic Thermal Relay Selection (oL1)	0 : Electronic thermal relay function disabled		0	
			1 : Inverter duty motor (with independent cooling fan)			
			2 : Standard motor (with shaft mounted cooling fan)			
	Pr5-19	Motor 1- Electronic Thermal Relay Characteristic	30~600 Sec		60	
	Pr5-20	IGBT Over-Heat pre-warning setting (oH2)	0.0~110.0		85.0	
	Pr5-21	Over-Torque Detection Selection 2 (ot2)	0: Disabled		0	
			1: Over-torque detection during constant speed operation, stop operation after detection.			
			2: Over-torque detection during constant speed operation, continue to operate after detection.			
			3: Over-torque detection during entire (acceleration, steady state,			

			deceleration) operation, stop operation after detection			
			4: Over-torque detection during entire (acceleration, steady state, and deceleration) operation, continue operation after detection.			
	Pr5-22	Over-Torque Detection Level 2 (ot2)	Amp(10~250% of drive's rated current)		A (150%)	
	Pr5-23	Over-Torque Detection Time 2 (ot2)	0.0~60.0 Sec		0.1	
	Pr5-24 {Pr5-21}	Most Recent Fault Record	0: no fault	16: HPF (protection circuit fault)	32: ot2 (Over-Torque2)	0
	Pr5-25 {Pr5-22}	2nd Most Recent Fault Record	1: oC (over-current)	17: oH1 (IGBT overheat)	33: oL2 (electronic thermal relay 2)	
	Pr5-26 {Pr5-23}	3rd Most Recent Fault Record	2: oU (over-voltage)	18: oH2 (Heat sink overheat)	34: rnot (Motor selection error)	
	Pr5-27 {Pr5-24}	4th Most Recent Fault Record	3: GF (ground fault)	19: SoFt (Pre-charge circuit error)		
◎	Pr5-28	5th Most Recent Fault Record	4: SC (IGBT failure)	20: ACI. (ACI error)	36: LUr (Low Voltage during Run)	
◎	Pr5-29	6th Most Recent Fault Record	5: oL (drive overload)	21: ASC (RS-485 error)	37: oUd (over-voltage during decel)	
◎	Pr5-30	7th Most Recent Fault Record	6: oL1 (electronic thermal relay 1)	22: PI.d (PID error)	38: `x Copy (Parameter copy error)	
◎	Pr5-31	8th Most Recent Fault Record	7: ot1 (Over-Torque1)	23: Pu (Keypad communication overtime)	39: LU (Low Voltage)	
◎	Pr5-32	9th Most Recent Fault Record	8: oCn (over-current during constant speed)	24: tunE (Auto tuning failure)	40: bb (External Base Block)	
◎	Pr5-33	10th Most Recent Fault Record	9: oCA (Over-current during accel.)	25: bF (braking chopper failure)		
◎	Pr5-34	11th Most Recent Fault Record	10: oCd (Over-current during decel.)	26:(Factory Reserved)		
◎	Pr5-35	12th Most Recent Fault Record	11: EP1 (EPROM error 1)	27: PHL (Phase-Loss protect or capacitor aged)		
◎	Pr5-36	13th Most Recent Fault Record	12: EP2 (EPROM error 2)	28: CC (current signal error during stop)		
◎	Pr5-37	14th Most Recent Fault Record	13: EF (external fault)	29: CPu (CPU error)		
◎	Pr5-38	15th Most Recent Fault Record	14: Ct1 (current sensor 1)	30: FAn (Fan failure)		
◎	Pr5-39	16th Most Recent Fault Record	15: Ct2 (current sensor 2)	31: AnI fault (Analog input error)		
★ ◎	Pr5-40	Full-Load Current of Motor 2	Amp (10~120% of drive's rated current)		xxxA (100%)	
◎	Pr5-41	Auto Torque Compensation of Motor 2	0.0~25.0%		0.0	
◎	Pr5-42	Slip Compensation of Motor 2	0~20 RPM		0	
◎	Pr5-43	Number of Motor Poles 2	2~20		4	

⊙	Pr5-44	Rotor Resistance R1 of Motor 2	0.000~65.535 Ω	0							
⊙	Pr5-45	Motor 2- Electronic Thermal Relay Selection (oL2)	0: Electronic thermal relay function disabled 1: Inverter duty motor (with independent cooling fan) 2: Standard motor (with shaft mounted cooling fan)	0							
⊙	Pr5-46	Motor 2- Electronic Thermal Relay Characteristic	30~600 Sec	60							
⊙	Pr5-47	Heat sink Over-Heat pre-warning setting (oH2)	0.0~110.0 °C	85.0							
⊙	Pr5-48	Delay Time for Motor Selection	0.00~60.00 Sec	0.05							
⊙	Pr5-49	Motor selection mode	<table border="1"> <tr> <td rowspan="2">Bit 0 (bxxxx0)</td> <td>0: Cannot be switch during operation.</td> </tr> <tr> <td>1: Can be switch during operation.</td> </tr> <tr> <td rowspan="2">Bit 1 (bxxx0x)</td> <td>0: No need to waiting for confirm signal when switching</td> </tr> <tr> <td>1: Need to waiting for confirm signal when switching</td> </tr> </table>	Bit 0 (bxxxx0)	0: Cannot be switch during operation.	1: Can be switch during operation.	Bit 1 (bxxx0x)	0: No need to waiting for confirm signal when switching	1: Need to waiting for confirm signal when switching	b00000	
Bit 0 (bxxxx0)	0: Cannot be switch during operation.										
	1: Can be switch during operation.										
Bit 1 (bxxx0x)	0: No need to waiting for confirm signal when switching										
	1: Need to waiting for confirm signal when switching										

Group 6: Special Parameters

	Parameters	Functions	Settings	Factory Setting	User
	Pr6-00	DC Braking Current Level	Amp (0~125% of drive's rated current)	A (0%)	
	Pr6-01	DC Braking Time during Start-up	0.00~60.00 Sec	0.00	
	Pr6-02	DC Braking Time during stopping	0.00~60.00 Sec	0.00	
	Pr6-03	Start-point for DC Braking during stopping	0.00~600.00 Hz	0.00	
	Pr6-04	Increasing Rate of the DC Braking Voltage	0.01~300.00%	50.00%	
	Pr6-05	Momentary Power Loss Operation Selection	0 : Operation stops after momentary power loss. 1 : Operation continues after momentary power loss, speed search Speed Search starts with Last Output Frequency Downward 2 : Operation continues after momentary power loss, speed search starts with the Start-up frequency Upward	0	
	Pr6-06	Maximum Allowable Power Loss Time	0.1~25.0 Sec	2.0	
	Pr6-07	Base-Block Time for Speed Search (BB)	0.1~5.0 Sec	0.5	
	Pr6-08	Maximum Current Level for Speed Search	Amp (20~200% of drive's rated current)	A (120%)	
	Pr6-09	Deceleration Time for Speed Search	0.50~120.00 Sec	3.00	
	Pr6-10	Auto Restart after Fault	0~30 times	0	
	Pr6-11	Speed Search during Start-up	0 : speed search disabled 1 : speed search through the frequency command 2 : FWD-speed search only (motor only runs in FWD direction) 3 : REV-speed search only (motor only runs in REV direction) 4 : FWD/REV speed search enabled in both directions (FWD first) 5 : REV/FWD speed search enabled in both directions (REV first)	0	

Pr6-12	Speed Search Frequency (FWD direction)	0.00~600.00 Hz	60.00/50.00	
Pr6-13	Speed Search Frequency (REV direction)	0.00~600.00 Hz	60.00/50.00	
Pr6-14	Dwell Time at Accel.	0.00~60.00 Sec	0.00	
Pr6-15	Dwell Frequency at Accel.	0.00~600.00 Hz	6.00	
Pr6-16	Dwell Time at Decel.	0.00~60.00 Sec	0.00	
Pr6-17	Dwell Frequency at Decel.	0.00~600.00 Hz	6.00	
Pr6-18	Dwell Frequency current	Amp (0~150% of rated current)	A (0%)	
Pr6-19	Traverse Skip Frequency	0.00~100.00Hz	0.00	
Pr6-20	The Amplitude of traverse	0.00~200.00Hz	0.00	

Group 7: High-function Parameters (PID and Communication)

Parameters	Functions	Settings	Factory Setting	User
Pr7-00	Proportional Gain (P)	0.0~500.0%	80.0	
Pr7-01	Integral Time (I)	0.00~100.00 Sec	1.00	
		0.00 : no integral		
Pr7-02	Derivative Control (D)	0.00~5.00 Sec	0.00	
Pr7-03	Upper limit for Integral Control	0.0~100.0%	100.0	
Pr7-04	PID Output Frequency Limit	0.0~100.0%	100.0	
Pr7-05	PID Offset	-100.0~+100.0%	0.0	
Pr7-06	Primary Delay Filter Time	0.000~0.100 Sec	0.000	
Pr7-07	PID Feedback Signal Detection Time	0.0~6000.0 Sec	0.0	
Pr7-08	Treatment of the Erroneous PID Feedback Signals	0: warn and keep operating	0	
		1: warn and RAMP to stop		
		2: warn and COAST to stop		
Pr7-09	Treatment of Keypad Transmission Fault	0: Warn and RAMP to stop	0	
		1: Warn and COAST to stop		
Pr7-10	Keypad Transmission Fault detection	0.0: Disable and keep operating	0.0	
		0.1~60.0 Sec		
Pr7-11	Communication Address	1~254	1	
Pr7-12	Transmission Speed (Baud rate)	1.2~125 Kbps	9.6	
Pr7-13	Transmission Fault Treatment	0: warn and keep operating	3	
		1: warn and RAMP to stop		
		2: warn and COAST to stop		
		3: No warning and keep operating		
Pr7-14	Time-out Detection	0.0: disabled	0.0	
		0.1~60.0 Sec		
Pr7-15	Communication Protocol	0 : 7,N,2 ASCII	0	
		9 : 8,E,2 ASCII		
		1 : 7,E,1 ASCII		
		10 : 8,O,2 ASCII		
		2 : 7,O,1 ASCII		
		11 : 8,N,1 RTU		
		3 : 7,E,2 ASCII		
		12 : 8,N,2 RTU		
		4 : 7,O,2 ASCII		
13 : 8,E,1 RTU				
5 : 8,N,1 ASCII				
14 : 8,O,1 RTU				
6 : 8, N,2 ASCII				
15 : 8,E,2 RTU				
7 : 8,E,1 ASCII				
16 : 8,O,2 RTU				
8 : 8,O,1 ASCII				

Group 8: Fan & Pump Control Parameters

Parameters	Functions	Settings	Factory Setting	User
★ Pr8-00	V/F Curve Selection	0: V/F Curve determined by Parameter Group 1	0	
		1: 1.5 Power Curve		
		2: Square Power Curve		
Pr8-01	Start-Up Frequency of the Auxiliary Motor	0.00~600.00 Hz	0.00	
Pr8-02	Stop Frequency of the Auxiliary Motor	5.00~600.00 Hz	5.00	
Pr8-03	Time Delay before Stopping the Auxiliary Motor	0.0~6000.0 Sec	0.00	
Pr8-04	Time Delay before Stopping the Auxiliary Motor	0.0~6000.0 Sec	0.00	
Pr8-05	Sleep Frequency	0.00~600.00 Hz	0.00	
Pr8-06	Wake-up Frequency	0.00~600.00 Hz	0.00	
Pr8-07	Sleep Time	0.0~6000.0 Sec	0.0	



Optional Digital Keypad only the features

ERROR MESSAGE AND TROUBLESHOOTING

The drive has a comprehensive fault diagnostic system that includes various alarms and fault messages such as over-voltage, low-voltage and over-current....etc. Once a fault is detected, the corresponding protective functions will be activated, and the drive will stop the output and the motor will then coast to stop. The following faults are displayed as shown on the drive digital keypad panel. Once the fault occurred, eliminate it first, and wait for 5 seconds (oC,GF,SC are 15 seconds) then execute RESET action to reactivate the operation.

User may either by depress RESET key on the keypad or apply a external reset signal from Mix to execute RESET action.



Problems and Solutions

Fault symbol	Fault descriptions (Name) {Error code}	Treatments
	<p style="text-align: center;">Over- current (oC) {01}</p> <p>The drive detects an abnormal increase in output current.</p>	<ul style="list-style-type: none"> ◆ Check the wiring connections between the driver and motor for possible short circuits. ◆ Increase the Acceleration time (Pr1-11, Pr1-12) ◆ Check for possible excessive loading conditions at the motor. ◆ Replace the drive with the next higher power model ◆ Wait for 15 seconds then execute RESET action to reactivate the operation.
	<p style="text-align: center;">Over-voltage on DC-Bus (oU) {02}</p> <p>The drive detects that the DC bus voltage has exceeded its maximum allowable value. 115/230 V class: about 400V 460 V class: about 800V</p>	<ul style="list-style-type: none"> ◆ Check whether the input voltage falls within the rated drive input voltage range. ◆ Check for possible voltage transients. ◆ If DC Bus over-voltage due to regenerative voltage, please increase the Deceleration time or add an brake unit and brake resistor (optional)

<p>oUd</p>	<p>Over-voltage on DC-Bus during deceleration (oUd) {37}</p> <p>The drive detects that the DC bus voltage has exceeded its maximum allowable value while in deceleration. 115/230 V class: about 400V 460 V class: about 800V</p>	<ul style="list-style-type: none"> ◆ Check whether the input voltage falls within the rated drive input voltage range. ◆ If DC Bus over-voltage due to regenerative voltage, please increase the Deceleration time or add an brake unit and brake resistor (optional) ◆ Check whether the required braking power is within the specified limits.
<p>GF</p>	<p>Ground fault (GF) {03}: When (one of) the output terminal(s) is grounded, short circuit current is more than 50% of drive rated current, the drive power module may be damaged. NOTE: The Ground fault protection is provided for drive protection, not for protection of the user..</p>	<ul style="list-style-type: none"> ◆ Check the wiring connections between the driver and motor for possible short circuits, also to ground ◆ Check whether the IGBT power module is damaged. ◆ Check for possible poor insulation at the output line ◆ Wait for 15 seconds then execute RESET action to reactivate the operation.
<p>SC</p>	<p>IGBT fault (SC) {04}</p> <p>Short-circuit is detected between upper bridge and lower bridge of the IGBT module.</p>	<ul style="list-style-type: none"> ◆ Check whether the motor's resistance and insulation are functioning right ◆ Check whether the connection to the motor is short circuited ◆ Return to the factory if the previous checking is normal ◆ Wait for 15 seconds then execute RESET action to reactivate the operation.
<p>oL</p>	<p>Drive overload (OL) {05}</p> <p>The drive detects excessive drive output current. The drive can withstand up to 150 % of the rated current for a maximum of 60 seconds.</p>	<ul style="list-style-type: none"> ◆ Check whether the motor is overloaded ◆ Reduce torque compensation setting as set in Pr5-01 ◆ Increase the acceleration time ◆ Replace the drive with the next higher power model
<p>oL 1</p>	<p>Motor overload -Thermal relay 1 (oL1) {06}</p> <p>(Electronic thermal relay 1 protection.)</p>	<ul style="list-style-type: none"> ◆ Check whether the motor 1 V/F setting proper ◆ Check whether the motor 1 running low speed for long period ◆ Check for possible motor 1 overload ◆ Check motor 1 full load current (Pr5-00) ◆ Check electronic thermal overload 1 setting (Pr5-18 to Pr5-19) ◆ Reduce the load so that the drive output current does not exceed the value set on Pr5-00 ◆ Increase motor capacity
<p>oT 1</p>	<p>Over-Torque1 detected (oT1) {07}</p>	<ul style="list-style-type: none"> ◆ Check whether the motor 1 is overloaded ◆ Check whether motor 1 rated current setting (Pr5-00) is suitable ◆ Check whether the Over-Torque1 detect parameter are suitable (Pr5-15~Pr5-17) ◆ Check whether the mechanical system is normal ◆ Increase motor 1 capacity and replace the drive with the next higher power model

oCn	Over-current during constant speed (oCn) {08}	<ul style="list-style-type: none"> ◆ Check for possible poor insulation at the output wires ◆ Check for possible motor stall ◆ Replace the drive with the next higher power model.
oCA	Over-current during acceleration (oCA) {09}	<ul style="list-style-type: none"> ◆ Check for possible poor insulation at the output wires ◆ Decrease the torque boost setting in Pr5-01 ◆ Increase the acceleration time ◆ Replace the drive with the next higher power model.
oCd	Over-current during deceleration (oCd) {10}	<ul style="list-style-type: none"> ◆ Check for possible poor insulation at the output wires ◆ Increase the deceleration time ◆ Replace the drive with the next higher power model
EP1	EPROM read error (EP1) {11}	<ul style="list-style-type: none"> ◆ Check whether the power voltage falls within the rated voltage ◆ Switch off power supply wait until display off then on again. ◆ Reset drive to factory defaults, return to the factory if not working
EP2	EPROM write error (EP2) {12}	
EF	External fault (EF) {13} (one of Pr2-01~Pr2-03 =14 and act)	<ul style="list-style-type: none"> ◆ Give RESET command after fault has been cleared Input
Ct1	U phase current sensor A/D fault (Ct1) {14}	<ul style="list-style-type: none"> ◆ Switch off power supply wait until display off then on again ,If fault code is still displayed please return to the factory. Replace a control board or U phase current sensor
Ct2	W phase current sensor A/D fault (Ct2) {15}	<ul style="list-style-type: none"> ◆ Switch off power supply wait until display off then on again ,If fault code is still displayed please return to the factory. ◆ Replace a control board or W phase current sensor
HPF	Hardware protection loop fault (HPF) {16}	<ul style="list-style-type: none"> ◆ Switch off power supply wait until display off then on again ,If fault code is still displayed please return to the factory.
oH1	IGBT overheat (oH1) {17} IGBT temperature exceeds protection level	<ul style="list-style-type: none"> ◆ Check the cooling fan and clean it ◆ Ensure that the ambient temperature falls within the specified ◆ Remove any foreign objects on the heat sinks and check for possible dirty heat sink fins. ◆ Make sure that the ventilation path is not obstructed. ◆ Provide enough spacing for adequate ventilation.
oH2	Environment overheat (oH2) {18} The drive temperature sensor detects excessive heat on environment.	<ul style="list-style-type: none"> ◆ Check the cooling fan and clean it ◆ Ensure that the ambient temperature falls within the specified ◆ Provide enough spacing for adequate ventilation.
SoFt	Inrush limit circuit fault (SoFt) {19}	<ul style="list-style-type: none"> ◆ Switch off power supply wait until display off then on again, If fault code is still displayed please return to the factory.
ASC	RS-485 serial port time-out (ASC) {21}	<ul style="list-style-type: none"> ◆ Check the RS-485 wiring
PId	PID feedback error (PI.d) {22}	<ul style="list-style-type: none"> ◆ Check the PID feedback wiring ◆ Check the PID parameters settings

Pu	PU communication error (Pu) {23}	<ul style="list-style-type: none"> ◆ Check whether the keypad communication circuit is well-conducted
tunE	Auto tuning failure (tunE) {24}	<ul style="list-style-type: none"> ◆ Check cabling between drive and motor. ◆ Check whether the motors horsepower corresponds to the drive output power. ◆ Retry again
bF	Braking chopper fault (bF) {25}	<ul style="list-style-type: none"> ◆ Switch off power supply wait until display off then on again, If fault code is still displayed please return to the factory.
PHL	Phase-Loss protect or capacitor aged (PHL) {27} Three phase imbalanced at the input voltage or the drive detects excessive ripple voltage on DC-Bus	<p>Caused of power source:</p> <ul style="list-style-type: none"> ◆ Check whether the power voltage is normal ◆ Check whether the screw at the input power terminal is tightened ◆ Check whether the power source phase-lacking <p>Caused of smoothing capacitor:</p> <ul style="list-style-type: none"> ◆ Check whether the smoothing capacitors life is ended.
CC	Current signal error during stop (CC) {28}	<ul style="list-style-type: none"> ◆ Reset the drive, if okay, then might be interference noise come into the drive. ◆ Return to the factory if previous method is not effect.
CPu	CPU error (CPu) {29} Electronics Circuit Fault	<ul style="list-style-type: none"> ◆ Switch off power supply wait until display off then on again, If fault code is still displayed please return to the factory.
FAn	Fan fault (FAn) {30}	<ul style="list-style-type: none"> ◆ Check whether the cooling fan is blocked ◆ Replace the fan
AnI	Analog input error (AnI.) {31}	<ul style="list-style-type: none"> ◆ Check if the analog input signal is out of range
ot2	Over-Torque2 detected (ot2) {32}	<ul style="list-style-type: none"> ◆ Check whether the motor 2 is overloaded ◆ Check whether motor 2 rated current setting (Pr5-40) is suitable ◆ Check whether the Over-Torque2 detect parameter are suitable (Pr5-21~Pr5-23) ◆ Check whether the mechanical system is normal ◆ Increase motor 2 capacity and replace the drive with the next higher power model
oL2	Motor overload -Thermal relay 2 (oL2) {33} (Electronic thermal relay 2 protection.)	<ul style="list-style-type: none"> ◆ Check whether the motor 2 V/F setting proper ◆ Check whether the motor 2 running low speed for long period ◆ Check for possible motor 2 overload ◆ Check motor 1 full load current (Pr5-40) ◆ Check electronic thermal overload 1 setting (Pr5-45 to Pr5-46) ◆ Reduce the load so that the drive output current does not exceed the value set on Pr5-40 ◆ Increase motor capacity
rnot	Motor select error (rnot) {34}	<ul style="list-style-type: none"> ◆ Check the motor wiring connection ◆ Check the parameters settings

	<p>Low voltage on DC-Bus during run (LUr) {36}</p> <p>The drive detects that the DC bus voltage has fallen below its minimum value during run</p>	<ul style="list-style-type: none"> ◆ Check whether the input power voltage is normal ◆ Check whether the power supply capacity is enough ◆ Check for possible sudden load ◆ Whether the 3-phase model is of the single-phase power input or the phase-lacking
	<p>Low voltage on DC-Bus (LU) {39}</p> <p>The drive detects that the DC bus voltage has fallen below its minimum value</p>	<ul style="list-style-type: none"> ◆ Check whether the Inrush limit by-pass circuit fault ◆ Check whether the input power was interrupted ◆ Check whether the input side magnetic contactor is normal
	<p>External Base Block (bb) {40}</p> <p>(one of Pr2-01~Pr2-03 =15 or 16 and act)</p>	<ul style="list-style-type: none"> ◆ When the external input terminal (B.B) is active, the drive output will be turned off. ◆ Deactivate the external input terminal (B.B) to operate the drive again.

Dimension:

Unit: mm(inch)

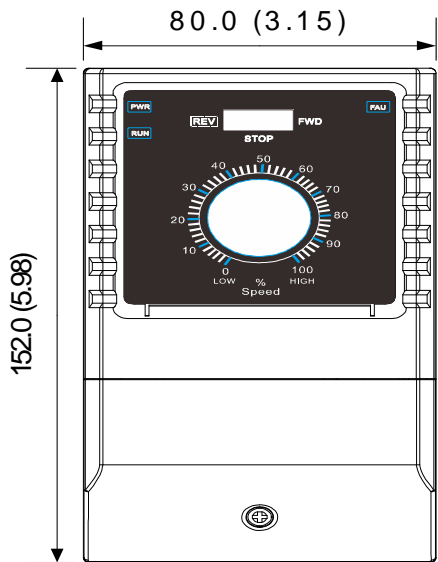

Front View

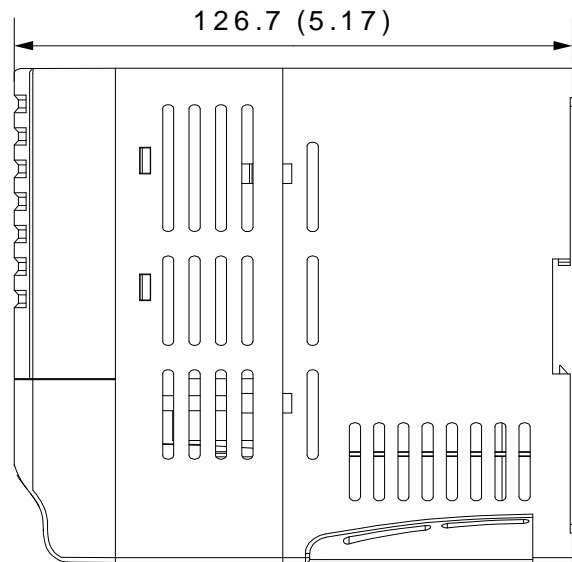

Side View

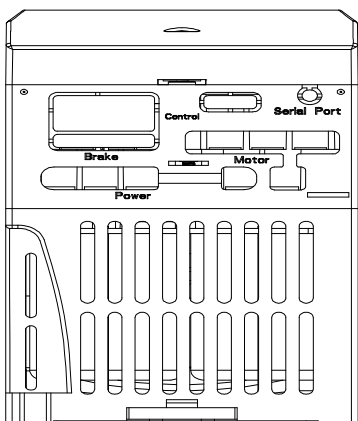

Bottom View

(Cooling fan at Top side)

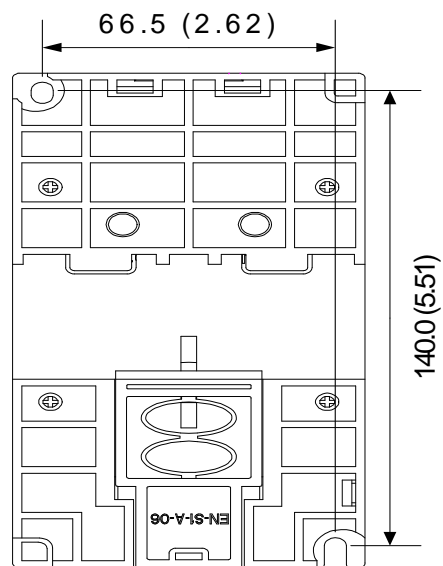

Rera View

5.0 (0.20)

序言

TOPVERT L1 系列產品採用了高品質之元件、材料及融合最新的微電腦控制技術製造而成。本手冊提供給使用者安裝及參數設定相關注意事項。為了確保能夠正確地安裝及操作變頻器，請在裝機之前，詳細閱讀本安裝手冊，若需更進一步瞭解各參數之詳細功能以及相關之應用規劃，異常診斷，異常排除，週邊設備選配及日常維護等，請參閱隨機所附的光碟，您也可在陽岡科技的公司網站上，自由下載取得。

版權聲明

本文件中的資料係陽岡科技的智慧財產。我們雖然盡了最大的努力製作此文件，但無法對內容的正確性提供百分之百保證。基於“還能更好”的品質政策，我們的產品恆於追求完美精益求精的路途中，因此我們保留了不告知變動的權利，但我們持續將最新版本的文件放於陽岡科技的公司網站上，供自由下載。

<http://www.toptek.biz>

本安裝手冊，煩請您確實交給本變頻器之最終使用者，以便發揮最大功能。謝謝！

變頻器乃精密的電力電子產品，為了操作者及機械設備的安全，請務必交由專業的電機工程人員安裝試車及調整參數，本手冊中有“危險”、“注意”等符號說明的地方請務必仔細研讀，若有任何疑慮的地方請連絡本公司各地的代理商洽詢，我們的專業人員會樂於為您服務。

以下為特別需要注意的事項：



1. 實施配線，務必關閉電源。
2. 切斷交流電源後，充電指示燈(CHARGE)未熄滅前，表示變頻器內部仍有高壓，十分危險，請勿觸摸內部電路及零組件。
3. 絕對不可以自行改裝變頻器內部的零件或線路。
4. 絕不可將變頻器輸出端子U/T1、V/T2、W/T3 連接至AC 電源。
5. 變頻器接地端子  務必正確的接地。230V 機種採第三種接地，460V機種採特種接地。



1. 切勿對變頻器內部的零組件進行耐壓測試，因內有半導體易受高壓擊穿而損壞。
2. 變頻器的電路板有cmos IC 極易受靜電的破壞，故在未做好防靜電措施前請勿用手觸摸電路板。
3. 即使電動機是停止的，變頻器的主迴路端子仍然可能有危險的高壓。
4. 只有合格的電機專業人員才可以安裝、配線及修理保養變頻器。
5. 當變頻器某些功能被設定後，可能在電源輸入後會立即啟動電動機開始運轉。
6. 請選擇安全的區域來安裝變頻器，防止高溫及日光直接照射，避免溼氣和水滴的潑濺。
7. 請防止小孩或一般無關人員接近變頻器。
8. 變頻器只能用在本公司所認可的場合，未經認可的使用環境可能導致火災、氣爆、感電等事件。
9. 當變頻器與電動機之間的配線過長時，對電動機的層間絕緣可能產生破壞，請改用變頻器專用的交流電動機，或在變頻器及電動機之間加裝電抗器或濾波器，避免造成交流電動機因絕緣破壞而燒毀。
10. 變頻器所安裝之電源系統額定：(230V級機種不可高於240V)，(460V級機種不可高於480V)，供應容量電流不可超大於5000A RMS。
11. 變頻器機殼對大地的漏電流(High leakage current)為22 mA。
12. 變頻器所控制的電動機應符合 IEC:60034-1。

機型貼紙說明

以 2.2kW/3Hp 230V 單(三)相 選配面板操作、RS-485 串列通訊埠、動態煞車器為例:

INVERTER (AC Drive)

Model: TOPVERT L1-2M2P2-1SD

Input: 1Φ 3Φ 200~240V 50/60Hz 12A

Output: 3 Phase 0~240V 11A 4.2kVA 2.2kW/3Hp

Output Frequency Range : 0.1~600Hz (FRN:3.009)



L1-2M2P2-1SD-08 T2509001

← 軟體版本 : 3.009

← CE 認證

陽岡科技股份有限公司 www.toptek.biz
 Toptek Electronics Corporation MADE IN TAIWAN

型號 →

輸入電源規格 →

輸出規格 →

輸出頻率範圍 →

生產管制條碼 →

生產管制之詳細資訊 →

型號說明

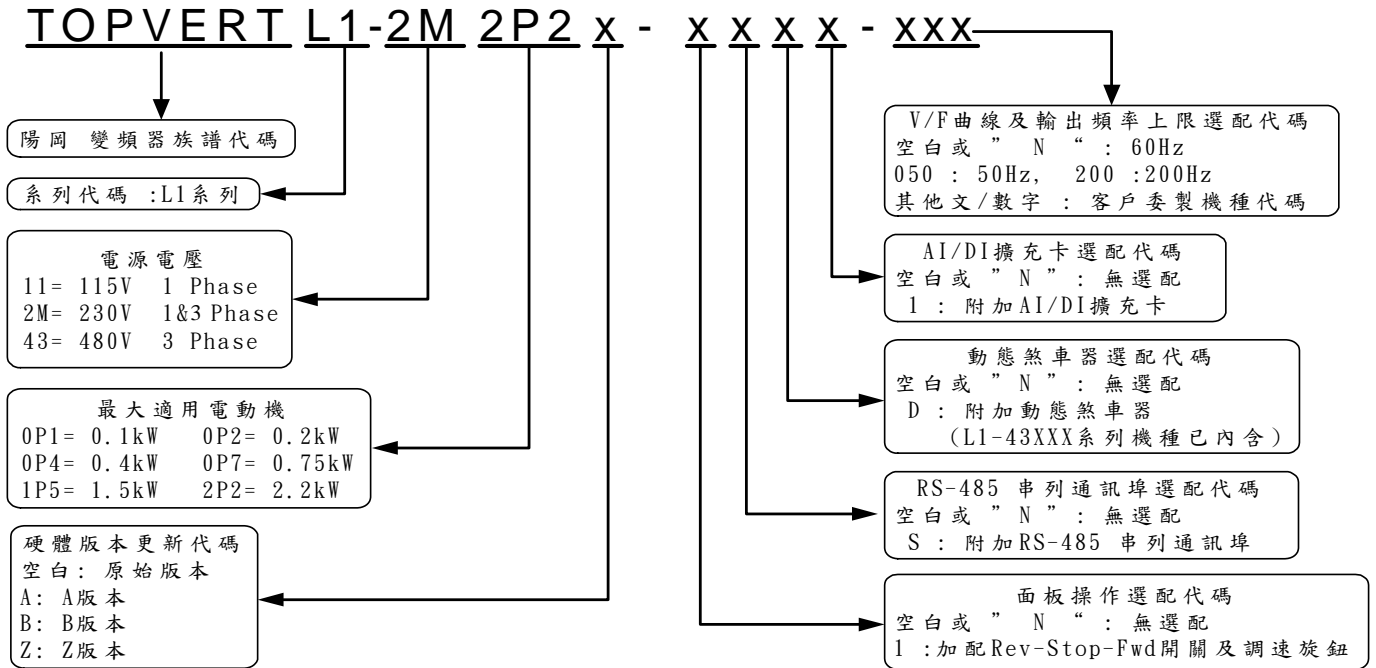

生產管制之資訊說明

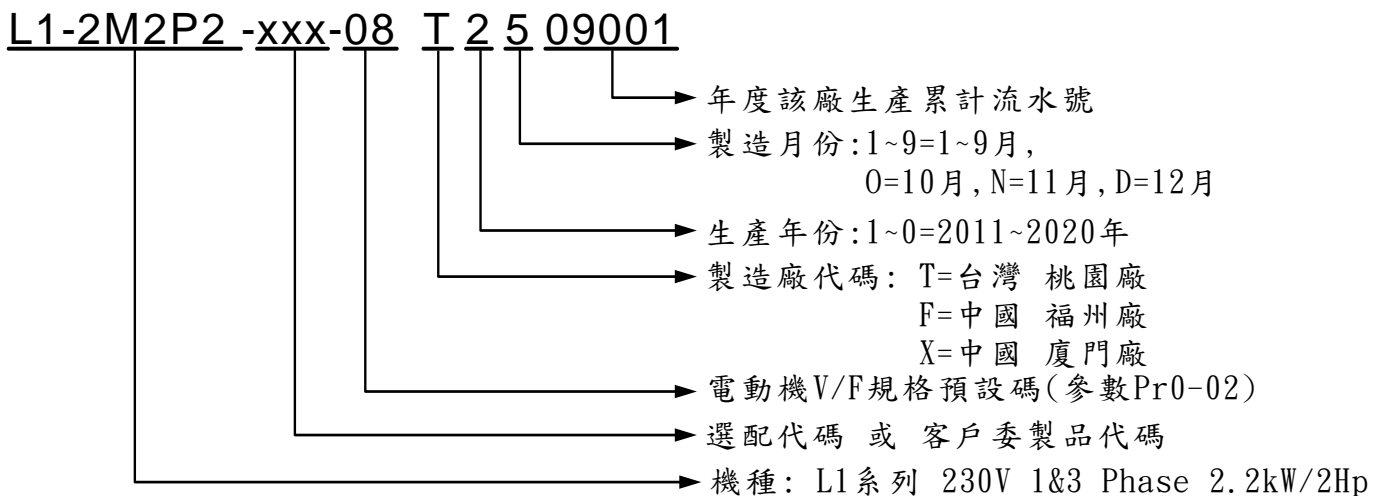

● 拆裝後如有任何登錄資料與您訂貨資料不符或有任何瑕疵，請您與接洽之代理商或經銷商聯絡。

標準規格

系列名稱		TOPVERT L1 系列 簡易迷你型	
輸出及控制特性	輸出頻率範圍	0.1 - 120Hz, 可規劃	
	過負載能力	額定輸出電流的 150%, 運轉 60 秒/10 分鐘, Ta ≤40 °C, 200% 運轉 3 秒	
	最大輸出電壓	對應輸入電源之電壓, 三相輸出	
	功因 / 效率	裝置之功率因數不低於 0.95, 裝置全載時之效率不低於 95%	
	控制方式	正弦波 PWM 向量控制 (有二種控制模式: V/F 模式及 無感向量模式, 可任意切換)	
	速度控制範圍	V/F 模式 20:1; 無感向量模式 120:1	
	頻率設定解析度	類比輸入: 10 Bit(1/1024), 數位輸入: 0.01Hz, 飛梭旋鈕輸入: 0.01Hz	
	頻率設定精準度	類比輸入: 最大輸出頻率之 ±0.2% 以內 (25°C ±10°C) 數位輸入: 所設定輸出頻率之 0.01% 以內	
	PWM 載波頻率	自 0.7kHz ~ 18kHz 可連續調整	
	轉矩提升	內建自動轉矩提升及自動滑差補償, 起動轉矩可達額定轉矩的 250%	
	禁止設定頻率	自 0.00 ~ 600Hz 可設定任意 6 點, 各點之寬度皆獨立可調	
	加速/減速時間	0.01 ~ 60000 秒 (2 段 加速/減速 時間可分別獨立設定)	
	失速防止	以變頻器額定電流的 0~250%, 加速中及定速運轉中皆可分別獨立設定	
	直流煞車制動	啟動時及停止時, 都可做直流制動, 制動電流為額定電流的 0 ~ 125%, 制動時間 0 ~ 60 秒獨立設定 停止時制動起始頻率 0.00 ~ 600Hz	
	回升動態煞車制動	煞車制動轉矩大約 20% (10% E. D.)	
	V/F 曲線	可設定的二組任意 V/F 曲線, 可設定轉矩特性曲線或遞減轉矩特性曲線	
操作特性	頻率設定方式信號	由數位操作面板	以 360 度編碼器式飛梭旋鈕設定 (分解度 0.01Hz/0.1Hz/1Hz/10Hz 可規劃)
		由外部端子	0 ~ 10VDC (輸入阻抗 20kΩ), 4 ~ 20mA DC (輸入阻抗 250Ω), 智慧型輸入端子 MI1-MI3 (15 段速, 上/下指令), 可程式運轉, 通訊設定 (RS-485)
	運轉操作方式信號	由數位操作面板	可由 RUN、STOP 鍵執行, 也可與外部端子切換/並用。
		由外部端子	2 線式 (FWD/STOP、REV/STOP、RUN/STOP、FWD/REV), 3 線式運轉, 通訊設定, RS-485 程式執行, 可程式運轉 (PLC Run)
	多功能數位輸入端子 (DI)	可規劃成下列功能: 15 段可預設速度切換, 第 1/2 加減速時間切換, 禁止加減速, 計數輸入, 暫時停機, 外部輸出遮斷, 輔助電動機控制失效, ACI/AVI 選擇, 變頻器重置, 15 段可程式運轉, 遞增/遞減頻率端子設定, 參數群選擇... 等多達 43 種功能	
	多功能接點輸出端子 (Ry)	由一個 "C" 接點的繼電器所組成。可規劃成下列功能: 運轉中, 停止中, 頻率到達輸出, 零速指示, 可程式運轉, 計數到達指示, 過轉矩, 外部輸出中斷, 多組輔助電機控制, 輸出低電壓報警, 操作模式, 故障指示, 變頻器準備完成, 過熱預警, 緊急停止... 等多達 63 種功能	
	多功能類比信號輸入端子 (AI1)	AVI: 0 ~ 10VDC (輸入阻抗 20kΩ), ACI: 4 ~ 20mA DC (輸入阻抗 250Ω) 有 1 組可規劃成 15 種不同功能	
	故障信號輸出接點	變頻器跳脫或故障時接點動作 "ON" (可規劃至一個 "C" 接點的繼電器, 一個 "A" 接點的繼電器輸出)	
通訊功能	RS-485 串列通訊埠, MODBUS protocol ASCII & RTU (傳輸速率可達 125 kbps) (選配)		
內建功能	PID 回授控制, 電源瞬停再起動, 自動穩壓輸出調節, 自動最佳化加/減速時間, S 曲線加/減速設定, 外部異常故障聯鎖/重置, 自動異常後再啟動, 16 次異常記錄, 自動節能運轉, 輸出頻率上下限設定, 可規劃的數位頻率信號輸出, 密碼鎖定, 風機/水泵程序控制, 睡眠/甦醒控制, 自動調適電機參數, By-Pass 切換, Y-Δ 運轉控制切換, 雙向自動速度追蹤, 禁止反轉, 4 段速運轉, 減速停止/滑行停止, 機械煞車聯鎖控制, 預警功能, 靜音運轉模式, 使用者定義多功能顯示內容, 過電流及過電壓失速防止, 電子熱動電驛, 內部計數器, 可控式散熱風扇, 可分離式數位操作器, 6 組共振點回避功能 (跳躍頻率)。		
智慧型保護功能	自我診斷, 電源過電壓, 欠相, 過電壓, 過電流, 低電壓, 過轉矩, 外部異常中斷, 電動機過負載, IGBT 模組過溫度, 散熱器過溫度, 電子熱動電驛, 輸出側接地保護, 輸出短路, 失速防止, 保險絲熔斷保護, IGBT 模組短路, 變頻器過負荷, 濾波電容老化監視及預警功能, 可依 IGBT 模組溫度自動調節 PWM 載波頻率, 16 次跳脫記錄, 可記錄跳脫時的運轉資訊如: DC-BUS 電壓, 輸出電壓/頻率/電流, 頻率指令, IGBT 溫度及散熱器之溫度等		
數位操作器 (選配)	6 個功能鍵: 可執行: 運轉、停止、重置、顯示頁面切換, 數值左移, 參數資料設定, 鍵盤運轉操作/外部運轉操作... 等 1 個以 360 度編碼器式飛梭旋鈕: 可設定頻率, 瀏覽, 修改及設定參數... 等 1 個 6 位數的 7 段節 LED 顯示器: 可顯示設定頻率, 實際輸出頻率, 電壓, 輸出電流, 電機轉向, 馬達轉速, 異常故障顯示, 使用者自定單位 (如輸入/輸出之電流, 電壓, 功率, 容量, 溫度, 時間, 馬達轉向... 計 88 種) 6 個狀態指示 LED 燈: 可分別顯示變頻器的運轉狀態, 運轉/停止, 正轉/反轉, 鍵盤運轉指令/外部運轉指令等 一個 RJ-45 插座: 操作器可外接, 遠程遙控距離可達 150 公尺以上		
環境	安全等級	符合 CE 之規範及 UL508C 之規範; 已內建簡易型射頻干擾 (RFI) 抑制濾波器, 當加裝本公司特定之濾波器時符合 EMC: EN61800-3 規範	
	溫度	操作環境: -10°C ~ +40°C (-10°C ~ +50°C) (無結露且無結凍); 儲存環境: -20°C ~ +60°C	
	濕度	98% R. H. 以下 (無結露)	
	安裝高度	高度 1000m 以下, 無腐蝕性氣體, 液體及粉塵	

*TOPVERT 全系列 規格均依 CNS, IEC, CE 及 UL 之規範設計及製造

單相電源, 100 ~ 120VAC, 50/60 Hz (容許變動範圍: 90 ~ 132V, 47 ~ 63Hz) 輸出電壓 : 200~240VAC

型號	適用電機 (230V 4 P)		額定輸出				電源	箱體結構				
	功率 (kW)	馬力 (Hp)	容量 (kVA)	電流 (A)	電壓 (V)	頻率 (Hz)		電流 (A)	冷卻 方式	保護構造 (IP/NEMA)	淨重 (kg)	外型框號
TOPVERT L1-xxxxx												
110P1	0.1				三相, 0-240 [最高]	0.1-600		強制 風冷	IP 20 NEMA 1		L1-A	
110P2	0.2	0.25	0.6	1.5			2.9			L1-B		
110P4	0.4	0.5	1.2	3			5.7					
110P7	0.75	1	2	5			9.5			L1-C		

單(三)相電源, 200 ~ 240VAC, 50/60 Hz (容許變動範圍: 180 ~ 264V, 47 ~ 63Hz)

型號	適用電機 (230V 4 P)		額定輸出				電源	箱體結構			
	功率 (kW)	馬力 (Hp)	容量 (kVA)	電流 (A)	電壓 (V)	頻率 (Hz)		電流 (A)	冷卻 方式	保護構造 (IP/NEMA)	淨重 (kg)
TOPVERT L1-xxxxx											
2M0P2	0.2	0.25	0.6	1.5	三相, 0-240 [最高]	0.1-600	2.9	強制 風冷	IP 20 NEMA 1	0.92	L1-B
2M0P4	0.4	0.5	1.2	3			5.7			0.92	
2M0P7	0.75	1	2	5			9.5			0.92	
2M1P5	1.5	2	3	7.5			14			1.10	
2M2P2	2.2	3	4.4	11			21				L1-C

三相電源, 380 ~ 480VAC, 50/60 Hz (容許變動範圍: 342 ~ 528V, 47 ~ 63Hz)

型號	適用電機 (460V 4 P)		額定輸出				電源	箱體結構			
	功率 (kW)	馬力 (Hp)	容量 (kVA)	電流 (A)	電壓 (V)	頻率 (Hz)		電流 (A)	冷卻 方式	保護構造 (IP/NEMA)	淨重 (kg)
TOPVERT L1-xxxxx											
430P4	0.4	0.5	1.3	1.6	三相, 0-460 [最高]	0.1-600	1.8	強制 風冷	IP 20 NEMA 1	0.89	L1-B
430P7	0.75	1	2.4	3			3.3			0.89	
431P5	1.5	2	3.3	4.2			4.6			0.89	
432P2	2.2	3	4.8	6			6.6				L1-C

基本配線圖

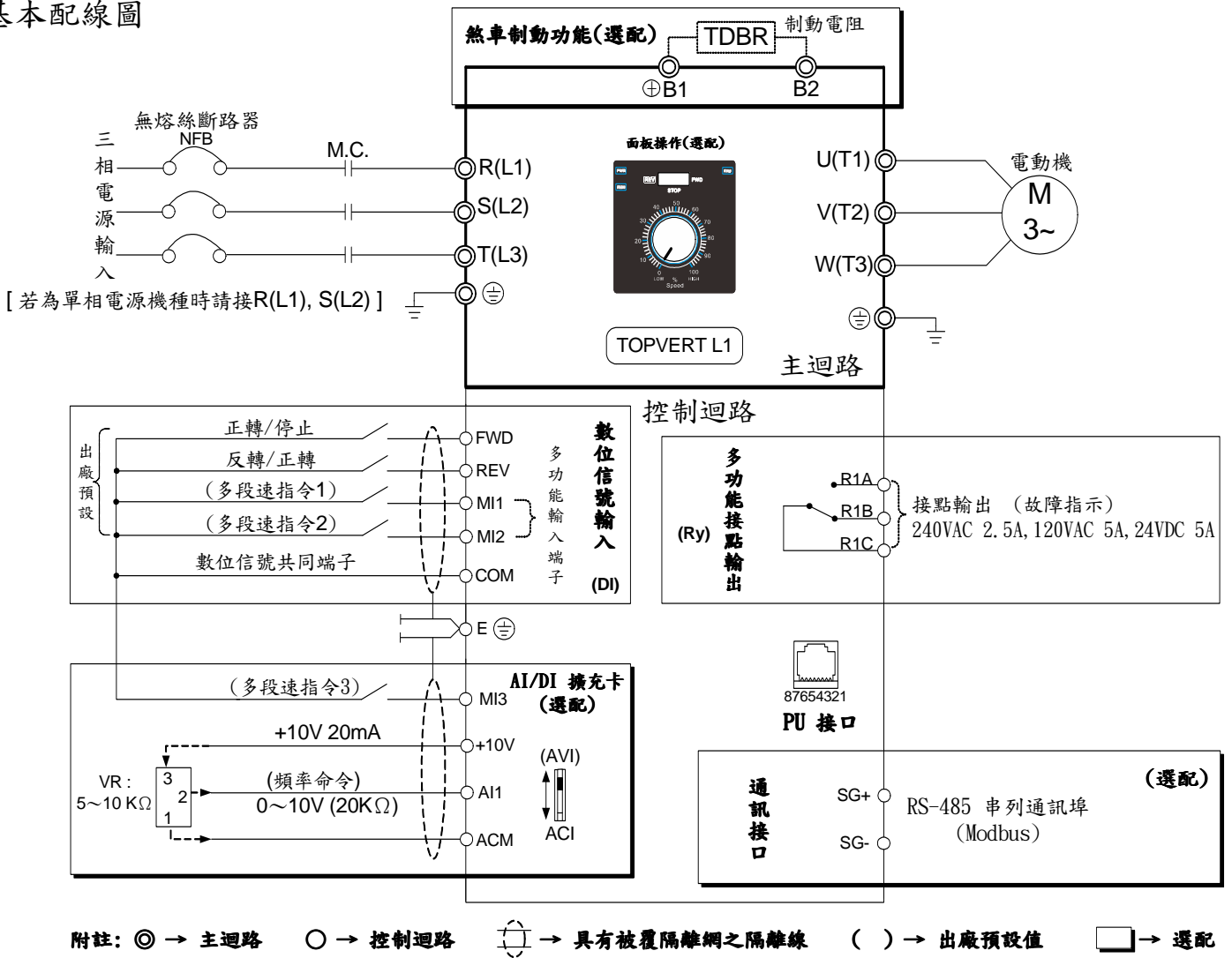

各功能位置說明

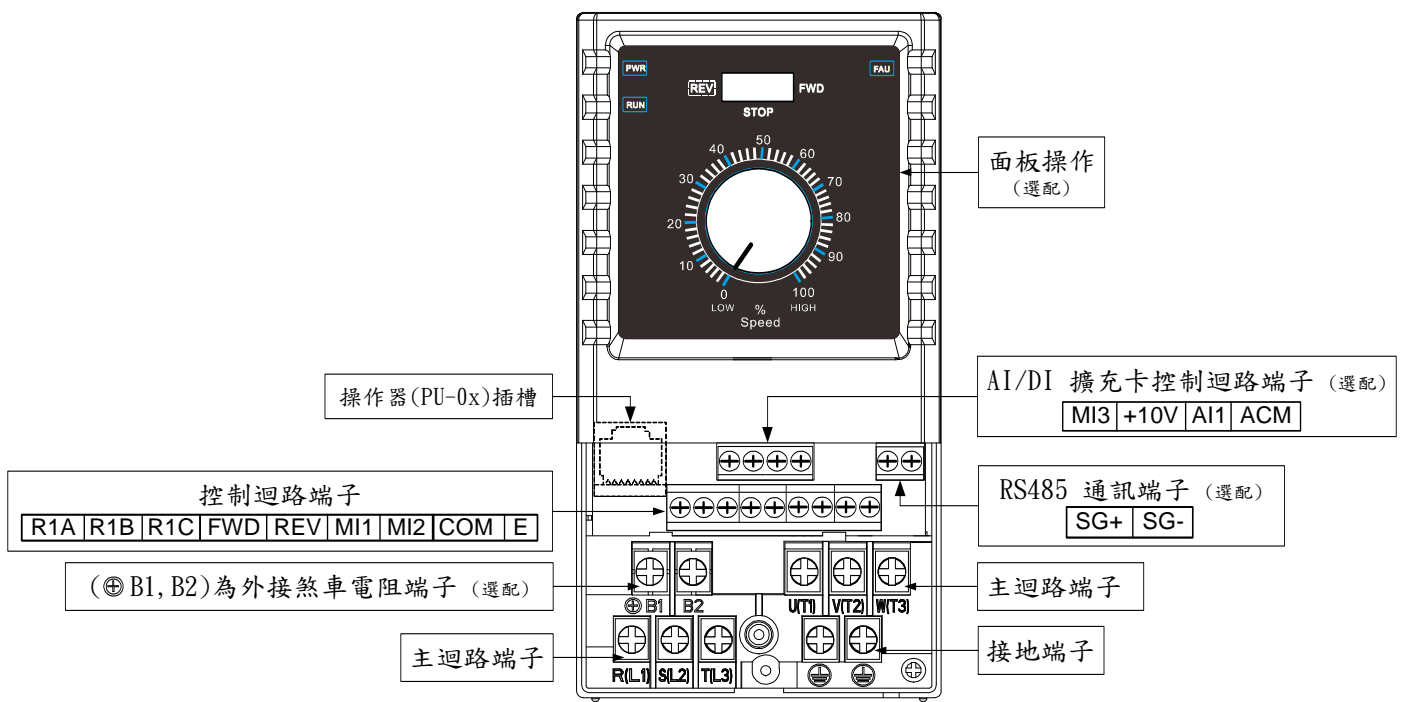

主迴路端子說明

端子記號	內容說明
R(L1), S(L2), T(L3)	主電源輸入端子, 接至商用電源 供應電源之電壓及容量應符合所安裝之變頻器所需
U(T1), V(T2), W(T3)	變頻器輸出端子, 接至三相感應電動機
⊕/B1, B2	外接煞車電阻連接端子
	接地端子, 請依電工法規: 230V機種第三種接地, 460V機種特種接地

控制端子標示說明

端子符號	端子功能說明	額定限制/對應參數位址 (出廠預設定功能)
數位信號輸入相關 (建議採用18 AWG (0.75 mm ²) 有遮蔽對絞線配線)		
MI1	多功能數位輸入端子 1 (三線式STOP指定端子)	Pr2-01/(多段速一命令)
MI2	多功能數位輸入端子 2	Pr2-02/(多段速二命令)
FWD	正轉運轉/停止 命令	Pr2-00/(正轉運轉/停止)
REV	反轉運轉/停止 命令	Pr2-00/(反轉運轉/停止)
繼電器接點輸出相關 (必須與其它所有的控制迴路端子分離配線)		
R1A	多功能輸出 1 (繼電器乾接點輸出) R1A-R1C :Relay 1 常開 (a接點) R1B-R1C :Relay 1 常閉 (b接點)	Pr2-20
R1B		電阻性負載 5A(N.O.)/3A(N.C.) 240VAC/24VDC
R1C		電感性負載 1.5A(N.O.)/0.5A(N.C.) 240VAC/24VDC
數位信號控制電源 及 接地端子 (建議採用18 AWG (0.75 mm ²)有遮蔽對絞線配線)		
E	數位及類比訊號隔離線, 外層披覆隔離網連接用的 接地端子.	
COM	數位/類比 控制信號的共同端。	
類比信號輸入輸出相關 (建議採用18 AWG (0.75 mm ²)有遮蔽對絞線配線)		
微弱的類比信號, 特別容易受外部雜訊干擾影響, 所以配線應盡可能短 (小於20m), 遮蔽對絞線的外圍網線基本上應接地 (E 端子), 但若現場的誘導雜訊大時, 連接到ACM端子的效果反而會較好. 如需在此電路中使用接點, 則應使用能處理弱信號的雙叉接點, 但ACM端子不要使用接點控制.		
[+10V]	+10V類比電壓源, 參考點為ACM	Max. 20mA/(+10V)
[AI1]	多功能類比輸入 1 (可選擇輸入電壓或電流信號) (當AI1 類比信號輸入選擇開關選擇" AVI" 時, 可 接入DC 0~10V 電壓信號. 選擇" ACI" 時, 可接 入DC 4(0)~20mA 電流信號)	Pr3-02/ (DC 0~10V 對應 頻率命令)
[ACM]	類比輸入與輸出信號的參考點	
通訊埠 相關 (建議採用18 AWG (0.75 mm ²)有遮蔽對絞線配線)		
[SG+]	RS-485 串列通訊埠的連接端子 +	應選用有遮蔽對絞線連接
[SG-]	RS-485 串列通訊埠的連接端子 -	

[] :需選配擴充卡才有此功能

操作面板各部位功能說明



操作功能說明

項目	功能說明
多功能輸入端子 (MI1、MI2)	多功能輸入設定方式: 1. 依出廠設定值 2. 依客戶指定
運轉命令端子 (FWD、REV)	可執行 正轉/停止、反轉/停止 命令
多功能接點輸出端子(R1A、R1B、R1C)	多功能接點輸出設定方式: 1. 依出廠設定值 2. 依客戶指定
PU 接口 (操作器插槽)	可連接數位操作器(PU-01及PU-05)

選配件一：

面板操作—REV-STOP-FWD 開關及調速旋鈕

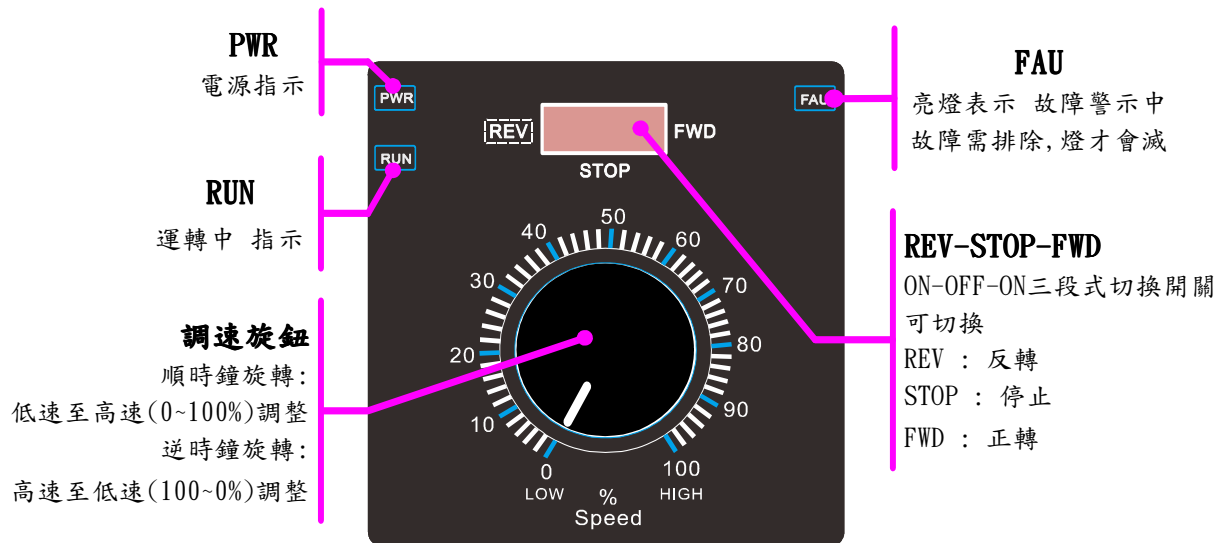

操作功能說明

項目	功能說明
多功能輸入端子 (MI1、MI2)	多功能輸入設定方式: 2. 依出廠設定值 2. 依客戶指定
運轉命令端子 (FWD、REV)	可執行 正轉/停止、反轉/停止 命令
多功能接點輸出端子(R1A、R1B、R1C)	多功能接點輸出設定方式: 2. 依出廠設定值 2. 依客戶指定
PU 接口 (操作器插槽)	可連接數位操作器(PU-01及PU-05)
REV-STOP-FWD 切換開關	採用ON-OFF-ON 三段式切換開關， 提供 正轉/停止/反轉(REV-STOP-FWD) 三種模式選擇
調速旋鈕	旋轉旋鈕可調整(0~100%)高/低速度

選配件二：
AI/DI 擴充卡

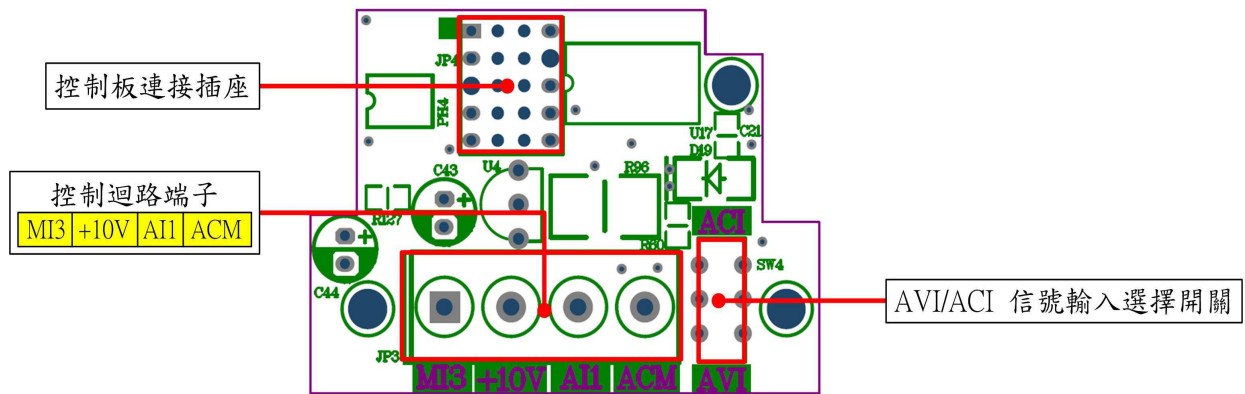

操作功能說明

項目	功能說明
外部數位信號 (DI) MI1、MI2、MI3 多功能輸入端子	數位信號多功能輸入設定方式： 1. 依出廠設定值 2. 依客戶指定
運轉命令端子 (FWD、REV)	可執行 正轉/停止、反轉/停止 命令
多功能接點輸出端子(R1A、R1B、R1C)	多功能接點輸出設定方式： 1. 依出廠設定值 2. 依客戶指定
PU 接口 (操作器插槽)	可連接數位操作器(PU-01及PU-05)
外部類比信號 (AI) AI1 多功能輸入端子	類比信號多功能輸入設定方式： 1. 依出廠設定值 2. 依客戶指定
AVI/ACI 信號輸入選擇	使用指撥開關可選擇輸入電壓或電流信號 選擇” AVI” 時,可接入DC 0~10V 電壓信號。 選擇” ACI” 時,可接入DC 4(0)~20mA 電流信號。

選配件三：

RS-485 串列通訊埠—通訊接口

操作功能說明

項目	功能說明
外部數位信號 (DI) MI1、MI2 多功能輸入端子	數位信號多功能輸入設定方式： 1. 依出廠設定值 2. 依客戶指定
運轉命令端子 (FWD、REV)	可執行 正轉/停止、反轉/停止 命令
多功能接點輸出端子(R1A、R1B、R1C)	多功能接點輸出設定方式： 1. 依出廠設定值 2. 依客戶指定
PU 接口 (操作器插槽)	可連接數位操作器(PU-01及PU-05)
通訊接口 RS-485串列通訊埠連接端子 (SG+、SG-)	提供RS-485串列通訊埠,並使用Modbus networks通訊協定進行串列通訊. 串列通訊埠以2 pin可拔式端子連接,應使用對絞線配綫,若欲使用8 pin RJ-45 插座連接時可另選購TB/ RJ-45轉換器.

選配件四：

數位操作器 PU-01

PU-01 數位操作器各部位功能說明

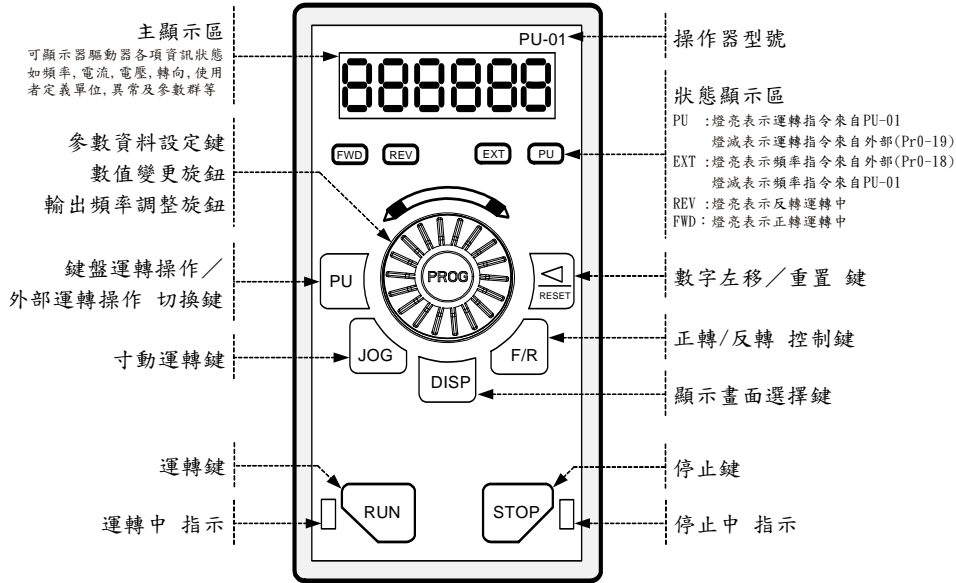

數位操作器 PU-05

PU-05 數位操作器各部位功能說明

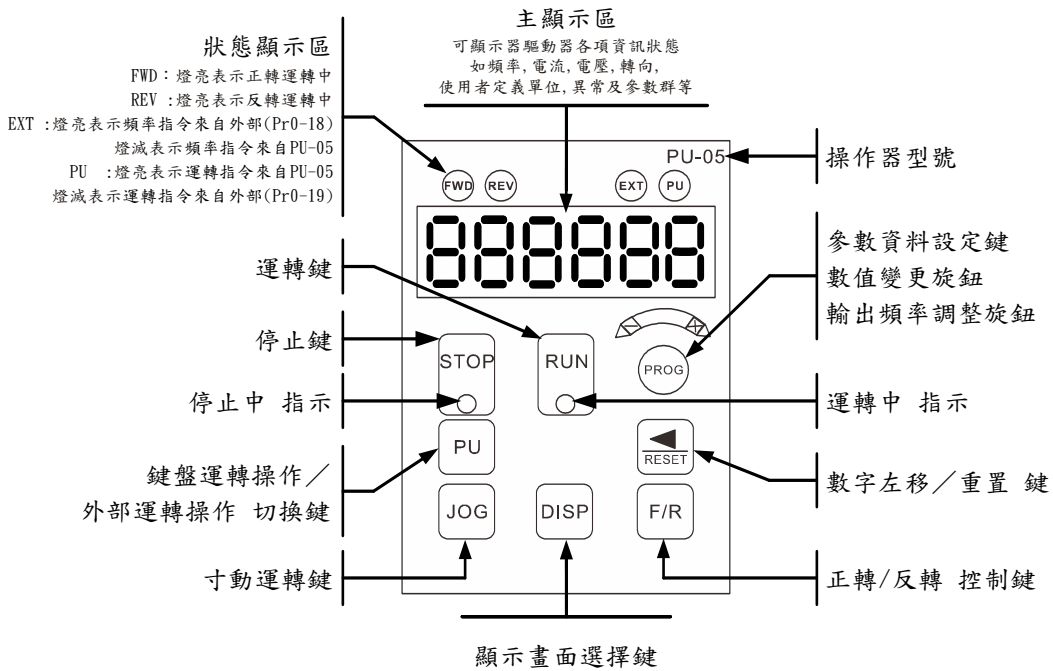

操作功能說明

項目	功能說明
外部數位信號 (DI) MI1、MI2 多功能輸入端子	數位信號多功能輸入設定方式: 2. 依出廠設定值 2. 依客戶指定
運轉命令端子 (FWD、REV)	可執行 正轉/停止、反轉/停止 命令
多功能接點輸出端子(R1A、R1B、R1C)	多功能接點輸出設定方式: 2. 依出廠設定值 2. 依客戶指定
PU 接口 (操作器插槽)	可連接數位操作器(PU-01及PU-05)
數位操作器 PU-01/PU-05	率先採用了360度編碼器式飛梭旋鈕, 使得參數的設定變的快速方便, 也突破了傳統可變電阻(VR)式旋鈕解析度低的缺點, 從數位操作器以飛梭旋鈕設定輸出頻率解析度可高達0.01Hz.

顯示功能說明

顯示項目	說明
	'F' 顯示變頻器目前的設定頻率 (可按 DISP 鍵觀看)
	'H' 顯示變頻器實際輸出到電動機的頻率 (可按 DISP 鍵觀看)
	'A' 顯示負載電流 (可按 DISP 鍵觀看)
	'u' 顯示用戶在多功能顯示選擇(Pr0-07)所選擇的內容 (可按 DISP 鍵觀看)
	顯示Read/Save的選擇內容 (只適用於PU-02) (可按 DISP 鍵觀看)
	選擇參數位址 (可“按下”與“旋轉”  飛梭旋鈕來選擇參數位址) (按下  鍵可依序顯示已更改過的參數位址)
	顯示參數內容值 (可“按下”與“旋轉”  飛梭旋鈕來設定參數內容值)
	表示資料已被接受並存入內部記憶體 (參數設定完成後按一下  旋鈕來完成資料存入內部記憶體並顯示End)

操作功能說明

顯示訊息的操作

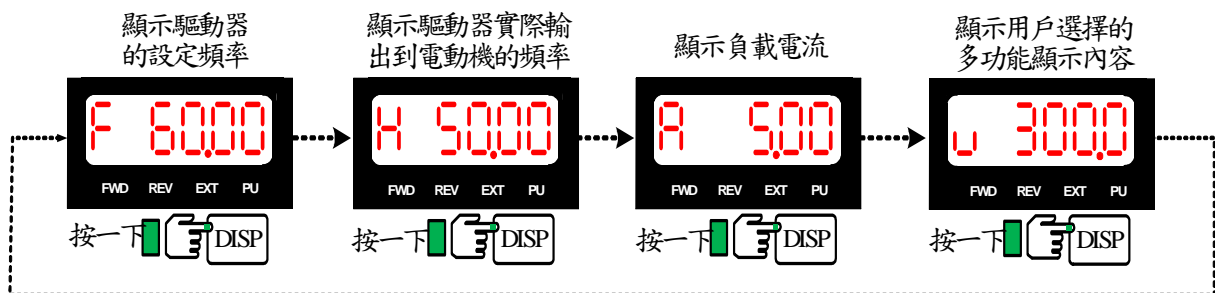

每按一下” DISP” 鍵，顯示器可在F頁面、H頁面、A頁面及U面切換

參數設定的操作 (以將Pr0-07設定成2 為例)

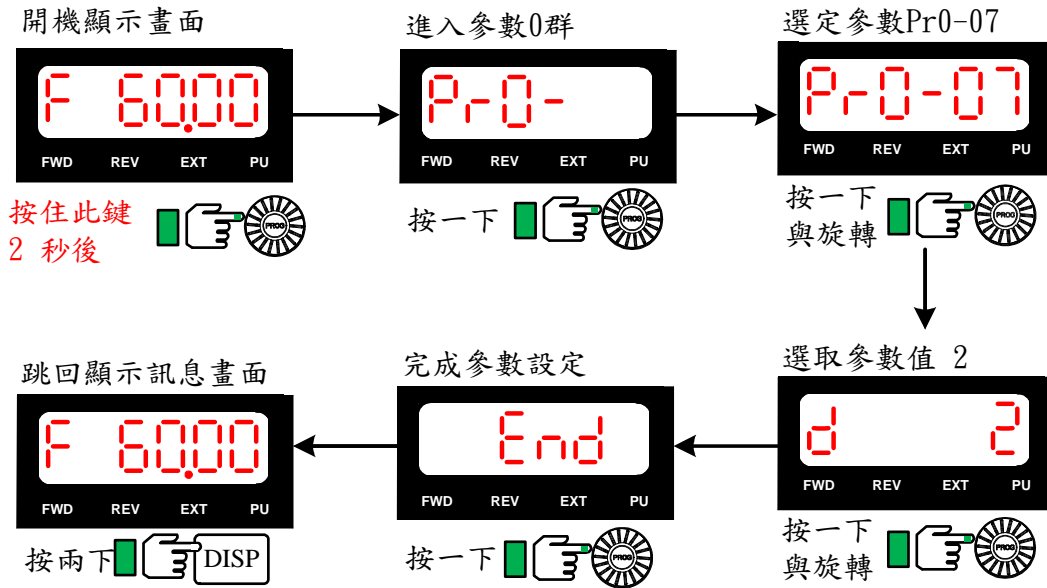

運轉的操作 (以從PU執行以50Hz運轉為例)

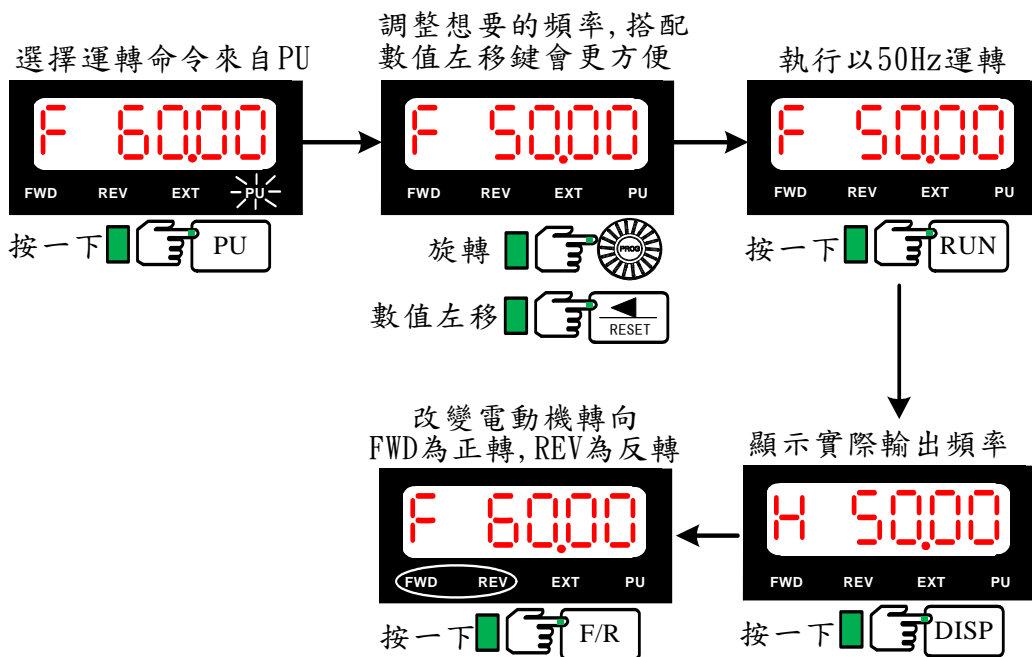

功能・參數一覽表

0 參數群：系統參數

★=運轉中不可設定 ◎:僅適用於韌體版本:2.xx以後之產品 []內為1.xx 韌體版本原參數編號

參數	參數功能	設定範圍	出廠值	客戶	
★ Pr0-00	機型顯示	依機型顯示,僅能讀取	工廠設定		
★ Pr0-01	額定輸出電流顯示	依機型顯示,僅能讀取	工廠設定		
★ Pr0-02	參數重置 (電動機規格選擇)	10: 參數重置成為符合 60Hz - 230/460V 之電動機的環境	8		
		9: 參數重置成為符合 50Hz - 220/380V 之電動機的環境			
		8: 參數重置成為符合 60Hz - 220/380V 之電動機的環境			
		7: 參數重置成為符合 50Hz - 230/460V 之電動機的環境			
		6: 參數重置成為符合 60Hz - 240/415V 之電動機的環境			
		5: 參數重置成為符合 50Hz - 240/415 之電動機的環境			
Pr0-03	參數保護密碼輸入 (鑰匙)	0~9999	0		
Pr0-04	參數保護密碼設定 (鎖頭)	0~9999	0		
Pr0-05	參數保護等級	Bit 0 (bxxxx0)	b00000		
		0: 所有參數皆可讀取			
		1: Pr0-05 之後的參數不可讀取。 (嘗試讀取會顯示"Err")			
		Bit 1 (bxxx0x)			0: 頻率命令可改
		1: 頻率命令不可改			
		Bit 2 (bxx0xx)	0: 數位操作器可執行運轉操作		
		1: 數位操作器不可執行運轉操作			
Pr0-06	預設開機顯示頁面	0: 顯示 頻率命令值 (F)	0		
		1: 顯示 實際輸出頻率 (H)			
		2: 顯示 輸出電流 (A)			
		3: 顯示 使用者於 Pr0-07 所定義的顯示內容 (U)			
Pr0-07	定義多功能顯示內容	0: 電動機轉速 (RPM)	0		
		1: DC-Bus 電壓 (Vdc)			
		2: 實際輸出電壓 (Vac)			
		3: 輸出電壓命令值 (Vac)			
		4: PID 回授頻率值 (Hz)			
		5: 多段速運轉執行中之段數			
		6: 睡眠時間 (Pr8-07)			
		7: 異常再啟動次數 (Pr6-10)			
		8: PID 命令值 (Hz)			
		9: (廠內保留)			
		10: 輸出功率因數 ()			
		11: 計數器計數值			
		12: 過轉矩檢出時間 1 (Pr5-17)			
		13: (廠內保留)			
		14: 加速時齒隙暫停時間 (Pr6-14)			
		15: 減速時齒隙暫停時間 (Pr6-16)			
		16: 啟動時直流制動時間 (Pr6-01)			
		17: 停車時直流制動時間 (Pr6-02)			
		18: 多段速運轉執行中未完時間			
		19: (廠內保留)			
		20: (廠內保留)			
		21: 累積上電的天數 (Day)			
		22: 累積上電的時間 (hh:mm)			
		23: (廠內保留)			
		24: (廠內保留)			
		25: (廠內保留)			
26: A11 端子比例值					

			27：(廠內保留)																										
			28：(廠內保留)																										
			29：(廠內保留)																										
			30：(廠內保留)																										
			31：(廠內保留)																										
			32：(廠內保留)																										
			33：(廠內保留)																										
			34：過轉矩檢出準位 1 (Pr5-16)																										
			35：電動機 1 自動轉矩補償(Pr5-01)																										
			36：(廠內保留)																										
			37：(廠內保留)																										
			38：定轉矩區恆速中失速防止電流值(Pr5-12)																										
			39~ 52：(廠內保留)																										
			53：輸出功率 (kW)																										
			54：輸出容量 (kVA)																										
			55：(廠內保留)																										
			56：IGBT 模組或散熱器溫度-TH1(°C)																										
			57：變頻器週溫-TH2 (°C)																										
			58~59 (廠內保留)																										
			60：變頻器過載累積時間 (Sec)																										
			61~63：(廠內保留)																										
			64：跳脫時 DC-Bus 電壓(Vdc)																										
			65：跳脫時輸出電壓值(Vac)																										
			66：跳脫時輸出頻率 (Hz)																										
			67：跳脫時 IGBT 模組的溫度 (°C)	◎																									
			68：跳脫時輸出電流值 (A)																										
			69：跳脫時變頻器週溫(°C)	◎																									
			70~86：(廠內保留)																										
			87：DC-Bus 漣波電壓(Vdc)	◎																									
			88：(廠內保留)	◎																									
			89~132：(廠內保留)																										
Pr0-08	使用者定義比例係數	0~39(不使用) 40~60000(對應於 Pr1-00 參數之含意)		0																									
Pr0-09	使用者定義比例之小數點位數	0~3 (0=無小數點, 1=小數點 1 位, 2=小數點 2 位, 3=小數點 3 位)		0																									
Pr0-10	韌體版本	僅能讀取		X. XX																									
Pr0-11	EPROM 儲存設定	<table border="1"> <tr> <td rowspan="2">Bit 0 (bxxxx0)</td> <td>0</td> <td>FWD/REV轉向命令會儲存</td> </tr> <tr> <td>1</td> <td>FWD/REV轉向命令不儲存, 關電後再通電會回復舊值</td> </tr> <tr> <td rowspan="2">Bit 1 (bxxx0x)</td> <td>0</td> <td>由PU來的頻率命令會儲存</td> </tr> <tr> <td>1</td> <td>由PU來的頻率命令不儲存, 關電後再通電會回復舊值</td> </tr> <tr> <td rowspan="2">Bit 2 (bxx0xx)</td> <td>0</td> <td>由RS485通訊埠來的頻率命令會記憶</td> </tr> <tr> <td>1</td> <td>由RS485通訊埠來的頻率命令不記憶, 關電後再通電會回復舊值</td> </tr> <tr> <td rowspan="2">Bit 3 (bx0xxx)</td> <td>0</td> <td>由Up/Down來的頻率命令會記憶</td> </tr> <tr> <td>1</td> <td>由Up/Down來的頻率命令不記憶, 關電後再通電會回復舊值</td> </tr> <tr> <td rowspan="2">Bit 4 (b0xxxx)</td> <td>0</td> <td>所異動的參數會記憶.</td> </tr> <tr> <td>1</td> <td>所異動的參數不記憶, 關電後再通電會回復舊值</td> </tr> </table>	Bit 0 (bxxxx0)	0	FWD/REV轉向命令會儲存	1	FWD/REV轉向命令不儲存, 關電後再通電會回復舊值	Bit 1 (bxxx0x)	0	由PU來的頻率命令會儲存	1	由PU來的頻率命令不儲存, 關電後再通電會回復舊值	Bit 2 (bxx0xx)	0	由RS485通訊埠來的頻率命令會記憶	1	由RS485通訊埠來的頻率命令不記憶, 關電後再通電會回復舊值	Bit 3 (bx0xxx)	0	由Up/Down來的頻率命令會記憶	1	由Up/Down來的頻率命令不記憶, 關電後再通電會回復舊值	Bit 4 (b0xxxx)	0	所異動的參數會記憶.	1	所異動的參數不記憶, 關電後再通電會回復舊值	b00000	
Bit 0 (bxxxx0)	0	FWD/REV轉向命令會儲存																											
	1	FWD/REV轉向命令不儲存, 關電後再通電會回復舊值																											
Bit 1 (bxxx0x)	0	由PU來的頻率命令會儲存																											
	1	由PU來的頻率命令不儲存, 關電後再通電會回復舊值																											
Bit 2 (bxx0xx)	0	由RS485通訊埠來的頻率命令會記憶																											
	1	由RS485通訊埠來的頻率命令不記憶, 關電後再通電會回復舊值																											
Bit 3 (bx0xxx)	0	由Up/Down來的頻率命令會記憶																											
	1	由Up/Down來的頻率命令不記憶, 關電後再通電會回復舊值																											
Bit 4 (b0xxxx)	0	所異動的參數會記憶.																											
	1	所異動的參數不記憶, 關電後再通電會回復舊值																											
Pr0-12	最佳化自動加/減速設定	<table border="1"> <tr> <td>0</td> <td>直線加速, 直線減速(無自動加速/減速)</td> </tr> <tr> <td>1</td> <td>自動加速, 直線減速</td> </tr> <tr> <td>2</td> <td>直線加速, 自動減速</td> </tr> <tr> <td>3</td> <td>自動加速, 自動減速</td> </tr> <tr> <td>4</td> <td>直線加/減速, 但以自動加/減速做失速防止</td> </tr> </table>	0	直線加速, 直線減速(無自動加速/減速)	1	自動加速, 直線減速	2	直線加速, 自動減速	3	自動加速, 自動減速	4	直線加/減速, 但以自動加/減速做失速防止	0																
0	直線加速, 直線減速(無自動加速/減速)																												
1	自動加速, 直線減速																												
2	直線加速, 自動減速																												
3	自動加速, 自動減速																												
4	直線加/減速, 但以自動加/減速做失速防止																												

★	Pr0-13	加/減速時間單位	0: 0.01 秒		0		
			1: 0.1 秒				
			2: 1 秒				
	Pr0-14	PWM 載波頻率上限	0=0.7kHz		請參照 Pr0-01		
1~18kHz							
	Pr0-15	PWM 載波頻率下限	0=0.7kHz		請參照 Pr0-01		
1~18kHz							
	Pr0-16	自動穩壓功能 (AVR)	0: 開啟自動穩壓功能		0		
1: 取消自動穩壓功能							
2: 減速時取消自動穩壓功能							
	Pr0-17	自動節能運轉(AESO)及其它	Bit 0 (bxxxx0)	0	取消自動節能運轉	b00000	
				1	開啟自動節能運轉		
			Bit 1 (bxxx0x)	0	最大輸出電壓可大於電源電壓 (可過調變)		
				1	最大輸出電壓等於電源電壓		
			Bit 2 (bxx0xx)	0	適用於:定轉矩通用負載		
				1	適用於:風機/水泵變轉矩負載		
			Bit 3 (bx0xxx)	0	負轉矩無滑差補償		
				1	負轉矩有滑差補償		
			Bit 4 (b0xxxx)	0	低噪音模式運轉		
				1	靜音模式運轉		
	Pr0-18	頻率命令來源設定	0: 由數位操作器(PU)		0		
1: 由RS485通訊埠							
2: 由外部類比信號端子							
3: 由外部 Up/Down 端子 (多功能輸入端子 MIx)							
4: (廠內保留)							
	Pr0-19	運轉命令來源設定	0: 由 RS485 通訊埠或數位操作器(PU)		0		
1: 由外部端子或數位操作器(PU)							
2: 由數位操作器(PU)							
3: 由外部端子							
	Pr0-20	停車/運轉/安全模式	Bit 0 (bxxxx0)	0	以減速煞車方式停止	b00000	
				1	以自由滑行方式停止		
			Bit 1 (bxxx0x)	0	外部端子運轉命令Reset後不可重新運轉		
				1	外部端子運轉命令Reset後可重新運轉		
			Bit 2 (bxx0xx)	0	外部端子不可電源通電運轉		
				1	外部端子可電源通電運轉		
			Bit 3 (bx0xxx)	0	正/反轉經過零點		
				1	正/反轉不經過零點		
			Bit 4 (b0xxxx)	0	高速區直線加/減速		
				1	高速區曲線加/減速		
	Pr0-21	轉向限制	0 可正反轉		0		
1 禁止反轉							
2 禁止正轉							
	Pr0-22	停機後等待時間	0.00~60.00 Sec		0.00		
	Pr0-23	散熱風扇控制及PID方向	Bit 0 (bxxxx0)	0	通電後風扇即運轉	b00001	
				1	運轉命令執行後風扇才運轉		
			Bit 1 (bxxx0x)	0	廠內保留		
				1	廠內保留		
			Bit 3	0	PID可反方向運轉		

			(bx0xxx)	1	PID禁止反方向運轉		
	Pr0-24	PU 飛梭旋鈕頻率解析度	0	0.01 Hz		1	
			1	0.10Hz			
			2	1.00Hz			
			3	10.00 Hz			
◎	Pr0-25	參數組別選擇	0	A 組參數		0	
			1	B 組參數			
			2	由 MI3 選擇 A 組或 B 組參數			

1 參數群：基本參數

參數	參數功能	設定範圍		出廠值	客戶
★ Pr1-00	最高操作頻率	3.00~600.00Hz		60.00/50.00	
★ Pr1-01	第一點頻率 1 (電動機 1 額定頻率) (Fbase 1)	0.00~600.00Hz		60.00/50.00	
Pr1-02	第一點電壓 1 (電動機 1 額定電壓) (Vbase 1)	230V 機種: 0.0~255.0V	460V 機種: 0.0~510.0V	230V: 230.0 460V: 460.0	
★ Pr1-03	第二點頻率 1 (中點頻率 1) (Fmid 1)	0.00~600.00Hz		0.50	
Pr1-04	第二點電壓 1 (中點電壓 1) (Vmid 1)	230V 機種: 0.0~255.0V	460V 機種: 0.0~510.0V	230V:5.0 460V:10.0	
★ Pr1-05	第三點頻率 1 (低點頻率 1) (Flow 1)	0.00~600.00Hz		0.50	
Pr1-06	第三點電壓 1 (低點電壓 1) (Vlow 1)	230V 機種: 0.0~255.0V	460V 機種: 0.0~510.0V	230V:5.0 460V:10.0	
Pr1-07	0Hz 電壓 1 (0Hz 輸出電壓 1) (V0Hz 1)	230V 機種: 0.0~25.5V	460V 機種: 0.0~51.0V	0.0	
Pr1-08	啟動頻率	0.00~600.00Hz		0.50	
Pr1-09	輸出頻率上限 (最高操作頻率 Pr1-00 之設定值=100%)	0.0~150.0%		110.0	
Pr1-10	輸出頻率下限 (最高操作頻率 Pr1-00 之設定值=100%)	0.0~100.0%		0.0	
Pr1-11	第一加速時間	0.00~60000 Sec		10.00/60.00	
Pr1-12	第一減速時間	0.00~60000 Sec		10.00/60.00	
Pr1-13	第二加速時間	0.00~60000 Sec		10.00/60.00	
Pr1-14	第二減速時間	0.00~60000 Sec		10.00/60.00	
Pr1-15	寸動加速時間	0.00~60000 Sec		10.00/60.00	
Pr1-16	寸動減速時間	0.00~60000 Sec		10.00/60.00	
Pr1-17	寸動頻率	0.00~600.00Hz		6.00	
Pr1-18	第一/第二 - 加減速時間 切換點的頻率	0.00~600.00Hz		0.00	
Pr1-19	S 曲線加速起始時間	0.00~12000 Sec		0.00	
Pr1-20	S 曲線加速到達時間	0.00~12000 Sec		0.00	
Pr1-21	S 曲線減速起始時間	0.00~12000 Sec		0.00	
Pr1-22	S 曲線減速到達時間	0.00~12000 Sec		0.00	
Pr1-23 [Pr1-29]	減速時電壓偏移量	230 機種: -50.0~50.0 V	460V 機種: -100.0~100.0V	0.0	
★ Pr1-24 [Pr1-23]	禁止設定頻率 1 上限	0.00~600.00Hz		0.00	
★ Pr1-25 [Pr1-24]	禁止設定頻率 1 下限	0.00~600.00Hz		0.00	
★ Pr1-26 [Pr1-25]	禁止設定頻率 2 上限	0.00~600.00Hz		0.00	
★ Pr1-27 [Pr1-26]	禁止設定頻率 2 下限	0.00~600.00Hz		0.00	
★ Pr1-28 [Pr1-27]	禁止設定頻率 3 上限	0.00~600.00Hz		0.00	

★	Pr1-29 [Pr1-28]	禁止設定頻率 3 下限	0.00~600.00Hz		0.00	
★ ◎	Pr1-30	禁止設定頻率 4 上限	0.00~600.00Hz		0.00	
★ ◎	Pr1-31	禁止設定頻率 4 下限	0.00~600.00Hz		0.00	
★ ◎	Pr1-32	禁止設定頻率 5 上限	0.00~600.00Hz		0.00	
★ ◎	Pr1-33	禁止設定頻率 5 下限	0.00~600.00Hz		0.00	
★ ◎	Pr1-34	禁止設定頻率 6 上限	0.00~600.00Hz		0.00	
★ ◎	Pr1-35	禁止設定頻率 6 下限	0.00~600.00Hz		0.00	
★ ◎	Pr1-36	第一點頻率 2 (電動機 2 額定頻率) (Fbase 2)	0.00~600.00Hz		60.00/50.00	
◎	Pr1-37	第一點電壓 2 (電動機 2 額定電壓) (Vbase 2)	230V 機種: 0.0~255.0V	460V 機種: 0.0~510.0V	230V:230.0 460V:460.0	
★ ◎	Pr1-38	第二點頻率 2 (中點頻率 2) (Fmid 2)	0.00~600.00Hz		0.50	
◎	Pr1-39	第二點電壓 2 (中點電壓 2) (Vmid 2)	230V 機種: 0.0~255.0V	460V 機種: 0.0~510.0V	230V:5.0 460V:10.0	
★ ◎	Pr1-40	第三點頻率 2 (低點頻率 2) (Flow 2)	0.00~600.00Hz		0.50	
◎	Pr1-41	第三點電壓 2 (低點電壓 2) (Vlow 2)	230V 機種: 0.0~255.0V	460V 機種: 0.0~510.0V	230V:5.0 460V:10.0	
◎	Pr1-42	0Hz 電壓 2 (0Hz 輸出電壓 2) (V0Hz 2)	230V 機種: 0.0~255.0V	460V 機種: 0.0~510.0V	0.0	

2 參數群：數位輸入/輸出 相關參數

參數	參數功能	設定範圍	出廠值	客戶	
★	Pr2-00	外部運轉控制的組態	0：二線式(1):正轉/停止, 反轉/停止 1：二線式(2):運轉/停止, 反轉/正轉 2：三線式(MI1) 運轉, 停止, 正轉/反轉	0	
★	Pr2-01	多功能數位輸入 MI1 (三線式運轉時, STOP指定端子)	0：無定義	1	
★	Pr2-02	多功能數位輸入 MI2 (計數輸入指定端子)	1：多段速命令一	2	
★	Pr2-03	多功能數位輸入 MI3	2：多段速命令二	3	
★	Pr2-04	(廠內保留)	3：多段速命令三		
★	Pr2-05	(廠內保留)	4：多段速命令四		
★	Pr2-06	(廠內保留)	5：異常復歸命令(Reset) 6：計數器清除命令 7：第一, 二加減速時間切換 8：禁止加/減速命令 9：強制頻率命令為 AV1 10：(廠內保留) 11：(廠內保留) 12：強制停止 13：PID 功能取消 14：EF 外部異常輸入 15：外部中斷(B.B.)由下往上追蹤 16：外部中斷(B.B.)由上往下追蹤 17：強制運轉命令由外部端子 18：取消最佳化自動加速/減速 19：(廠內保留)	0	

			20：(廠內保留)																											
			21：(廠內保留)																											
			22：取消可編程自動程序運轉(PLC Run)																											
			23：暫停可編程自動程序運轉(PLC Run)																											
			24：頻率遞增命令(Up Command)																											
			25：頻率遞減命令(Down Command)																											
			26：零速以直流制動模式取代																											
			27：暫時停機																											
			28：取消 加/減速時齒隙暫停																											
			29：取消擺頻功能																											
			30：取消啟動時速度追蹤																											
			31：EEPROM 不寫入																											
			32：計數器觸發信號輸入(指定MI2)																											
			33~41：廠內保留																											
			42：電動機切換命令		◎																									
			43：電動機切換完成確認信號		◎																									
			44：禁止反轉		◎																									
			45：禁止正轉		◎																									
	Pr2-07	頻率遞增/遞減之加/減速模式	<table border="1"> <tr> <td rowspan="2">Bit 0 (bxxxx0)</td> <td>0</td> <td>頻率遞增(Up)時依加速時間遞增</td> <td rowspan="6">◎</td> <td rowspan="6">b00000</td> </tr> <tr> <td>1</td> <td>頻率遞增(Up)時依 Pr2-08 所指定速率遞增</td> </tr> <tr> <td rowspan="2">Bit 1 (bxxx0x)</td> <td>0</td> <td>頻率遞減(Down)時依減速時間遞減</td> </tr> <tr> <td>1</td> <td>頻率遞減(Down)時依 Pr2-08 所指定速率遞減</td> </tr> <tr> <td>Bit 2 (bxx0xx)</td> <td></td> <td>廠內保留</td> </tr> <tr> <td rowspan="2">Bit 3 (bx0xxx)</td> <td>0</td> <td>FWD/REV 端子依邊緣觸發動作 (Edge trigger)</td> </tr> <tr> <td>1</td> <td>FWD/REV 端子依準位觸發動作 (Level trigger)</td> </tr> <tr> <td rowspan="2">Bit 4 (b0xxxx)</td> <td>0</td> <td rowspan="2">(廠內保留)</td> <td>◎</td> </tr> <tr> <td>1</td> </tr> </table>	Bit 0 (bxxxx0)	0	頻率遞增(Up)時依加速時間遞增	◎	b00000	1	頻率遞增(Up)時依 Pr2-08 所指定速率遞增	Bit 1 (bxxx0x)	0	頻率遞減(Down)時依減速時間遞減	1	頻率遞減(Down)時依 Pr2-08 所指定速率遞減	Bit 2 (bxx0xx)		廠內保留	Bit 3 (bx0xxx)	0	FWD/REV 端子依邊緣觸發動作 (Edge trigger)	1	FWD/REV 端子依準位觸發動作 (Level trigger)	Bit 4 (b0xxxx)	0	(廠內保留)	◎	1		
Bit 0 (bxxxx0)	0	頻率遞增(Up)時依加速時間遞增	◎		b00000																									
	1	頻率遞增(Up)時依 Pr2-08 所指定速率遞增																												
Bit 1 (bxxx0x)	0	頻率遞減(Down)時依減速時間遞減																												
	1	頻率遞減(Down)時依 Pr2-08 所指定速率遞減																												
Bit 2 (bxx0xx)		廠內保留																												
Bit 3 (bx0xxx)	0	FWD/REV 端子依邊緣觸發動作 (Edge trigger)																												
	1	FWD/REV 端子依準位觸發動作 (Level trigger)																												
Bit 4 (b0xxxx)	0	(廠內保留)	◎																											
	1																													
	Pr2-08	頻率遞增/遞減 (Up/Down) 命令之指定速率	0.01~1.00 Hz/mSec (也等於:10~1000Hz/Sec)		0.01																									
	Pr2-09	數位輸入端子濾波時間	0.000~30.000 Sec		0.005																									
◎	Pr2-10	數位輸入端子極性	00000~007FF (外部端子閉合定義為"0")		h00000																									
	Pr2-11	目標計數值	0~65500		0																									
	Pr2-12	指定預警到達計數值	0~65500		0																									
	Pr2-13	(廠內保留)	(廠內保留)																											
	Pr2-14	任意頻率到達 1	0.00~600.00Hz		60.00/50.00																									
	Pr2-15	任意頻率到達 1 檢出幅度	0.00~600.00Hz		2.00																									
	Pr2-16	任意頻率到達 2	0.00~600.00Hz		60.00/50.00																									
	Pr2-17	任意頻率到達 2 檢出幅度	0.00~600.00Hz		2.00																									
	Pr2-18	(廠內保留)	(廠內保留)																											
◎	Pr2-19	(廠內保留)	(廠內保留)																											
	Pr2-20 [Pr2-19]	多功能數位輸出 1 (Relay 1)	0：無定義		11																									
	Pr2-21 [Pr2-20]	(廠內保留)	1：運轉中																											
	Pr2-22 [Pr2-21]	(廠內保留)	2：運轉頻率到達1 (正轉及反轉均有效)																											
	Pr2-23 [Pr2-22]	(廠內保留)	3：運轉頻率到達2 (正轉及反轉均有效)																											

◎	Pr2-24	(廠內保留)	4: 任意頻率到達 1 (正轉及反轉均有效)	
		(廠內保留)	5: 任意頻率到達 1 (只有正轉有效)	
◎	Pr2-25		6: 任意頻率到達 2 (正轉及反轉均有效)	
			7: 任意頻率到達 2 (只有正轉有效)	
			8: 減速中	
			9: 變頻器準備完成	
			10: 低電壓警報 (LU) (LUr)	
			11: 變頻器故障	
			12: 外部中斷中 (B. B.)	
			13: 零速(含停機)	
			14: 零速 (必須在 RUN 命令執行中)	
			15: 目標計數值到達	
			16: 指定預警計數值到達	
			17: 可編程自動程序運轉 (PLC Run) 執行中	
			18: 可編程自動程序運轉 (PLC Run) 暫停	
			19: 可編程自動程序運轉(PLC Run) 一階段運轉完成	
			20: 可編程自動程序運轉 (PLC Run) 完成	
			21: OH1 過熱預警告	
			22: 加/減速時齒隙暫停中	
			23: 變頻器設定為外部端子運轉控制模式	
			24: 過轉矩輸出 1(ot1)	
			25: (廠內保留)	
			26: (廠內保留)	
			27: 輔助電動機 1	
			28: 輔助電動機 2	
			29: 輔助電動機 3	
			30: 過轉矩輸出 2 (ot2)	◎
			31: OH2 過熱預警告	◎
			32: 電動機切換輸出	◎
			33~47: 廠內保留	
			48: 主速頻率命令執行中	
			49: 自動程序運轉(PLC Run)第 1 段執行中	
			50: 自動程序運轉(PLC Run)第 2 段執行中	
			51: 自動程序運轉(PLC Run)第 3 段執行中	
			52: 自動程序運轉(PLC Run)第 4 段執行中	
53: 自動程序運轉(PLC Run)第 5 段執行中				
54: 自動程序運轉(PLC Run)第 6 段執行中				
55: 自動程序運轉(PLC Run)第 7 段執行中				
56: 自動程序運轉(PLC Run)第 8 段執行中				
57: 自動程序運轉(PLC Run)第 9 段執行中				
58: 自動程序運轉(PLC Run)第 10 段執行中				
59: 自動程序運轉(PLC Run)第 11 段執行中				
60: 自動程序運轉(PLC Run)第 12 段執行中				
61: 自動程序運轉(PLC Run)第 13 段執行中				
62: 自動程序運轉(PLC Run)第 14 段執行中				
63: 自動程序運轉(PLC Run)第 15 段執行中				
64~79: 廠內保留				

3 參數群：類比 輸入/輸出 相關參數

參數	參數功能	設定範圍	出廠值	客戶
Pr3-00	類比輸入相加減功能	0 可相加減	0	
		1 不可相加減		
Pr3-01	類比輸入濾波時間	0.00~2.00 Sec	0.10	
Pr3-02	A11 類比輸入功能	0: 無功能	1	

	(選配)	1: 頻率命令(Pr1-00=100%) 2: 調整第一加/減速時間 (如同 Pr1-11, Pr1-12) 3: 恆速中過電流失速防止準位調整 (如同 Pr5-12) 4: 加速中過電流失速防止準位 (如同 Pr5-10) 5: 過轉矩檢出準位 1 調整(如同 Pr5-16) 6: 電動機 1 自動轉矩補償調整 (如同 Pr5-01) 7: 頻率命令來源單一為 AI1 時的輔助頻率信號 8: (廠內保留) 9: (廠內保留) 10: 主頻的輔助頻率信號 11: PID 回授信號 12: PID 偏移信號 (如同 Pr7-05) 13: 直流制動電流準位調整(如同 Pr6-00) 14: 運轉中輸出電壓調整 (僅適用於 AI1: Pr3-02) 15: 外部溫度信號顯示及保護 16: 轉矩調整			
	Pr3-03	AI1 類比輸入偏壓 (選配)	-10.00~10.00V	0.00	
	Pr3-04	AI1 類比輸入增益(選配)	-500.0~+500.0%	100.0	
	Pr3-05	AI1 偏壓模式 (選配)	0 以偏壓為中心 1 低於偏壓=偏壓 2 高於偏壓=偏壓 3 以偏壓為中心取絕對值	0	

4 參數群：多段速運轉(MSS Run)與可編程自動程序運轉(PLC Run)相關參數

參數	參數功能	設定範圍	出廠值	客戶
Pr4-00	PLC Run 或 MSS Run 第一段速度	0.00~600.00Hz	0.00	
Pr4-01	PLC Run 或 MSS Run 第二段速度	0.00~600.00Hz	0.00	
Pr4-02	PLC Run 或 MSS Run 第三段速度	0.00~600.00Hz	0.00	
Pr4-03	PLC Run 或 MSS Run 第四段速度	0.00~600.00Hz	0.00	
Pr4-04	PLC Run 或 MSS Run 第五段速度	0.00~600.00Hz	0.00	
Pr4-05	PLC Run 或 MSS Run 第六段速度	0.00~600.00Hz	0.00	
Pr4-06	PLC Run 或 MSS Run 第七段速度	0.00~600.00Hz	0.00	
Pr4-07	PLC Run 或 MSS Run 第八段速度	0.00~600.00Hz	0.00	
Pr4-08	PLC Run 或 MSS Run 第九段速度	0.00~600.00Hz	0.00	
Pr4-09	PLC Run 或 MSS Run 第十段速度	0.00~600.00Hz	0.00	
Pr4-10	PLC Run 或 MSS Run 第十一段速度	0.00~600.00Hz	0.00	
Pr4-11	PLC Run 或 MSS Run 第十二段速度	0.00~600.00Hz	0.00	
Pr4-12	PLC Run 或 MSS Run 第十三段速度	0.00~600.00Hz	0.00	

	Pr4-13	PLC Run 或 MSS Run 第十四段速度	0.00~600.00Hz	0.00			
	Pr4-14	PLC Run 或 MSS Run 第十五段速度	0.00~600.00Hz	0.00			
	Pr4-15	PLC Run 或 MSS Run 主速時間	0.0~6550.0 Sec	0.0			
	Pr4-16	PLC Run 或 MSS Run 第一段時間	0.0~6550.0 Sec	0.0			
	Pr4-17	PLC Run 或 MSS Run 第二段時間	0.0~6550.0 Sec	0.0			
	Pr4-18	PLC Run 或 MSS Run 第三段時間	0.0~6550.0 Sec	0.0			
	Pr4-19	PLC Run 或 MSS Run 第四段時間	0.0~6550.0 Sec	0.0			
	Pr4-20	PLC Run 或 MSS Run 第五段時間	0.0~6550.0 Sec	0.0			
	Pr4-21	PLC Run 或 MSS Run 第六段時間	0.0~6550.0 Sec	0.0			
	Pr4-22	PLC Run 或 MSS Run 第七段時間	0.0~6550.0 Sec	0.0			
	Pr4-23	PLC Run 或 MSS Run 第八段時間	0.0~6550.0 Sec	0.0			
	Pr4-24	PLC Run 或 MSS Run 第九段時間	0.0~6550.0 Sec	0.0			
	Pr4-25	PLC Run 或 MSS Run 第十段時間	0.0~6550.0 Sec	0.0			
	Pr4-26	PLC Run 或 MSS Run 第十一段時間	0.0~6550.0 Sec	0.0			
	Pr4-27	PLC Run 或 MSS Run 第十二段時間	0.0~6550.0 Sec	0.0			
	Pr4-28	PLC Run 或 MSS Run 第十三段時間	0.0~6550.0 Sec	0.0			
	Pr4-29	PLC Run 或 MSS Run 第十四段時間	0.0~6550.0 Sec	0.0			
	Pr4-30	PLC Run 或 MSS Run 第十五段時間	0.0~6550.0 Sec	0.0			
	Pr4-31	PLC Run 或 MSS Run 時間倍數	1~10	1			
◎	Pr4-32	PLC Run 或 MSS Run 各段速之旋轉方向	00000~07FFF (0:正轉;1:反轉)	h00000			
	Pr4-33	(PLC Run)可編程自動程序運轉模式	Bit 0 (bxxxx0)	0	旋轉方向由 Pr4-32 決定	◎	b01000
1				旋轉方向由主速決定			
Bit 1 (bxxx0x)			0	無零速間隔運轉 (連續模式)			
			1	有零速間隔運轉 (STOP 模式)			
Bit 2 (bxx0xx)			0	暫停時以零速運轉			
			1	暫停時以該段原定速度運轉			
Bit 3 (bx0xxx)	0	電源中斷復電後,再啟動時從頭執行					
	1	電源中斷復電後,再啟動時從中斷處繼續執行					
	Pr4-34	(PLC Run)可編程自動程序運轉執行週期	0:可編程自動程序運轉無效	0			
1~60000:執行 1~60000 次週期							
60001:持續循環運轉							
	Pr4-35	(PLC Run)可編程自動程序運轉完成後之動作	0~15:依主速或多段速之一運轉(0=主速)	16			
16:停止運轉							

Pr4-36	(MSS Run)多段速運轉模式	Bit 0 (bxxxx0)	0	旋轉方向由Pr4-32 決定	b00001		
			1	旋轉方向由主速決定			
		Bit 1 (bxxx0x)	0	各段速的運轉時間由依MIx之多段速端子控制			
			1	各段速的運轉時間由Pr4-15~Pr4-30 的設定值決定			
		Bit 2 (bxx0xx)	0	無零速間隔運轉 (連續模式)			
			1	有零速間隔運轉 (STOP 模式)			
		Bit 3 (bx0xxx)	0	PID偏移無效			
			1	多段速 + PID 偏移有效			
		Bit 4 (b0xxxx)	0	(廠內保留)			◎
			1	(廠內保留)			◎

5 參數群：電動機調適及保護參數

參數	參數功能	設定範圍	出廠值	客戶	
★ Pr5-00	電動機 1 滿載電流	安培 (變頻器額定輸出電流之 10~120%)	xxxA(100%)		
Pr5-01	電動機 1 轉矩補償	0.0~25.0 %	0.0		
◎ Pr5-02	電動機 1 滑差補償	0~20% RPM (依 Pr1-01 設定頻率對應之 2 極至 20 極電動機的同步轉速*20%)	0		
Pr5-03	電動機 1 極數	2~20	4		
Pr5-04	電動機 1 R1 值	0.000~65.535 Ω	0.0		
★ Pr5-05	電動機參數自動調適及控制模式切換	0	不自動調適	0	
		1	依Pr5-00 所設定的電流值執行電動機參數自動調適並切換成無感測向量控制模式		
		2	重置已調適的參數並恢復成 V/F 模式		
★ Pr5-06	低電壓保護恢復準位	230V 機種: 160~220Vac	460V 機種: 320~440Vac	230V:180 420V:360	
Pr5-07	過電壓失速防止準位	230V 機種: 320~500VDC	460V 機種: 640~1000VDC	230V:380 460V:760	
Pr5-08	回生動態煞車準位設定	230V 機種: 320~500VDC	460V 機種: 640~1000VDC	230V:373 460V:746	
Pr5-09	電源欠相保護	0	提出警告但繼續運轉 (若輸出電流在額定的50%以下)		0
		1	提出警告並且減速停止		
		2	提出警告並且滑行停止		
Pr5-10	恆定轉矩輸出區加速時過電流失速防止準位	安培 (變頻器額定輸出電流之 10~250%)		xxxA (170%)	
Pr5-11	恆定馬力輸出區加速時過電流失速防止下限準位	安培 (變頻器額定輸出電流之 0~250%)		xxxA (120%)	
Pr5-12	恆定轉矩輸出區恆速運轉中過電流失速防止準位	安培 (變頻器額定輸出電流之 10~250%)		xxxA (170%)	
Pr5-13	恆定馬力輸出區恆速運轉中過電流失速防止下限準位	安培 (變頻器額定輸出電流之 0~250%)		xxxA (120%)	
Pr5-14	失速防止動作時之減速時間	0.50~120.00 Sec		3.00	
Pr5-15	過轉矩檢出功能 1 選擇 (ot1)	0	不檢測		0
		1	恆速運轉中過轉矩檢出時停止運轉		
		2	恆速運轉中過轉矩檢出時繼續運轉		
		3	運轉中過轉矩檢出時停止運轉		
		4	運轉中過轉矩檢出時繼續運轉		
Pr5-16	過轉矩檢出準位 1	安培 (變頻器額定輸出電流之 10~250%)		xxxA (150%)	
Pr5-17	過轉矩檢出時間 1	0.0~60.0 Sec		0.1	

Pr5-18	電動機 1 電子熱動電驛選擇 (oL1)	0	電子熱動電驛功能關閉			0
		1	使用變頻專用電動機 (獨立散熱, 不需考量變頻器的輸出頻率)			
		2	使用標準電動機 (同軸散熱, 需考量變頻器的輸出頻率)			
Pr5-19	電動機 1 電子熱動電驛動作時間	30~600 Sec			60	
Pr5-20	IGBT 過熱預警告溫度設定 1 (OH1)	0.0~110.0°C			85.0	
◎ Pr5-21	過轉矩檢出功能 2 選擇 (ot2)	0	不檢測			0
		1	恆速運轉中過轉矩檢出時停止運轉			
		2	恆速運轉中過轉矩檢出時繼續運轉			
		3	運轉中過轉矩檢出時停止運轉			
		4	運轉中過轉矩檢出時繼續運轉			
◎ Pr5-22	過轉矩檢出準位 2	安培 (變頻器額定輸出電流之 10~250%)			xxxA(150%)	
◎ Pr5-23	過轉矩檢出時間 2	0.0~60.0 Sec			0.1	
Pr5-24 [Pr5-21]	最後一次異常記錄	0: 無異常記錄	16: HPF (硬體保護迴路異常)	32: ot2 (過轉矩 2 檢出動作)	0	
Pr5-25 [Pr5-22]	前一次異常記錄	1: Oc (輸出側過電流)	17: oH1 (IGBT 模組內部或散熱器溫度過高)	33: oL2 (電動機 2 過負載)	0	
Pr5-26 [Pr5-23]	前二次異常記錄	2: oU (DC-bus 過電壓)	18: oH2 (變頻器箱體過溫過高) (或其它特定監測點溫度超過容許值)	34: rnot (電動機切換異常)	0	
Pr5-27 [Pr5-24]	前三次異常記錄	3: GF (輸出側對地漏電)	19: SoFt (預充電限流迴路異常)		0	
◎ Pr5-28	前四次異常記錄	4: SC (IGBT 模組異常)		36: LUr (運轉中 DC-bus 低電壓)	0	
◎ Pr5-29	前五次異常記錄	5: oL (變頻器過載)	21: ASC (RS485 串列埠通訊傳輸逾時)	37: oUd (減速時 DC-bus 過電壓)	0	
◎ Pr5-30	前六次異常記錄	6: oL1 (電動機 1 過負載)	22: PI.d (PID 回授訊號異常)	38: x CoPY (參數複製錯誤)	0	
◎ Pr5-31	前七次異常記錄	7: ot1 (過轉矩 1 檢出動作)	23: Pu (操作器 (PU) 斷線逾時)	39: LU (DC-bus 低電壓)	0	
◎ Pr5-32	前八次異常記錄	8: oCn (恆速運轉中輸出側過電流)	24: tunE (電動機參數調適失敗)	40: bb (外部中斷)	0	
◎ Pr5-33	前九次異常記錄	9: oCA (加速時輸出側過電流)	25: bF (動能煞車迴路異常)		0	
◎ Pr5-34	前十次異常記錄	10: oCd (減速時輸出側過電流)			0	
◎ Pr5-35	前十一次異常記錄	11: EP1 (EEPROM 記憶體資料讀出異常)	27: PHL DC-Bus連波電壓過高 (電源欠相)		0	
◎ Pr5-36	前十二次異常記錄	12: EP2 (EEPROM 記憶體資料寫入異常)	28: CC (停機中電流訊號異常)		0	
◎ Pr5-37	前十三次異常記錄	13: EF (外部異常輸入動作)	29: CPu (變頻器偵測線路異常)		0	
◎ Pr5-38	前十四次異常記錄	14: Ct1 (U 相電流傳感迴路或 A/D 轉換迴路異常)	30: FAn (散熱風扇異常)		0	
◎ Pr5-39	前十五次異常記錄	15: Ct2 (W 相電流傳感迴路或 A/D 轉換迴路異常)	31: An1 (類比輸入信號異常)		0	
★ Pr5-40	電動機 2 滿載電流	***A (10~120%)			xxxA (100%)	

◎	Pr5-41	電動機 2 自動轉矩補償	0.0~25.0%	0.0		
◎	Pr5-42	電動機 2 滑差補償	0~20% RPM (依 Pr1-36 設定頻率對應之 2 極至 20 極電動機的同步轉速*20%)	0		
◎	Pr5-43	電動機 2 極數	2~20	4		
◎	Pr5-44	電動機 2 R1 值	0.000~65.535Ω	0.0		
◎	Pr5-45	電動機 2 電子熱動電驛選擇(OL2)	0	電子熱動電驛功能關閉	0	
			1	使用變頻專用電動機 (獨立散熱,不需考量變頻器的輸出頻率)		
			2	使用標準電動機 (同軸散熱,需考量變頻器的輸出頻率)		
◎	Pr5-46	電動機 2 電子熱動電驛動作時間	30~600 Sec	60		
◎	Pr5-47	變頻器過熱預警告溫度設定 2 (OH2)	0.0~110.0°C	75.0		
◎	Pr5-48	電動機切換完成確認信號之容許等待時間	0.00~60.00 Sec	0.05		
◎	Pr5-49	電動機切換模式	Bit 0 (bxxxx0)	0	運轉中不可切換	b00000
				1	運轉中可切換	
			Bit 1 (bxxx0x)	0	切換時不需等待確認信號	
				1	切換時必需等待確認信號	

6 參數群：特殊參數

參數	參數功能	設定範圍	出廠值	客戶
Pr6-00	直流制動電流準位	安培 (變頻器額定輸出電流之 0~125%)	A(0%)	
Pr6-01	啟動時直流制動時間	0.00~60.00 Sec	0.00	
Pr6-02	停車時直流制動時間	0.00~60.00 Sec	0.00	
Pr6-03	停車時直流制動起始頻率	0.00~600.00Hz	0.00	
Pr6-04	直流制動電壓的增加速率	0.01~300.00%	20.00	
Pr6-05	瞬時停電後再運轉選擇	0	瞬時停電後不繼續運轉	0
		1	瞬時停電後由停電前速度往下追蹤繼續運轉	
		2	瞬時停電後由啟動頻率往上追蹤繼續運轉	
Pr6-06	允許瞬時停電之最長時間設定	0.1~25.0 Sec	2.0	
Pr6-07	速度追蹤之延遲時間設定(B.B.時間)	0.1~5.0 Sec	0.5	
Pr6-08	速度追蹤動作電流準位	安培(變頻器額定輸出電流之 20~200%)	xxxA (120%)	
Pr6-09	速度追蹤減速時間	0.50~120.00 Sec	3.00	
Pr6-10	異常自動再啟動次數	0~30	0	
Pr6-11	啟動時速度追蹤	0	不執行啟動時速度追蹤	0
		1	依頻率命令做速度追蹤	
		2	只執行正向速度追蹤	
		3	只執行反向速度追蹤	
		4	執行正/反向速度追蹤 (正向優先)	
		5	執行反/正向速度追蹤 (反向優先)	
Pr6-12	正向啟動時速度追蹤頻率	0.00~600.00Hz	60.00/50.00	
Pr6-13	反向啟動時速度追蹤頻率	0.00~600.00Hz	60.00/50.00	
Pr6-14	加速時齒隙暫停時間	0.00~60.00 Sec	0.00	
Pr6-15	加速時齒隙暫停頻率	0.00~600.00Hz	6.00	
Pr6-16	減速時齒隙暫停時間	0.00~60.00 Sec	0.00	
Pr6-17	減速時齒隙減速暫停頻率	0.00~600.00Hz	6.00	
Pr6-18	齒隙暫停中之電流限制	安培 (變頻器額定輸出電流之 0~150%)	A(0%)	

Pr6-19	擺頻功能跳躍頻率	0.00~100.00Hz	0.00	
Pr6-20	擺頻功能頻率寬度	0.00~200.00Hz	0.00	

7 參數群：PID 及 通訊傳輸相關參數

參數	參數功能	設定範圍	出廠值	客戶
Pr7-00	PID 比例值增益 (P)	0~500%	80	
Pr7-01	PID 積分時間 (I)	0.00~100.00 Sec	1.00	
		0.00：無積分		
Pr7-02	PID 微分時間 (D)	0.00~5.00 Sec	0.00	
Pr7-03	PID 積分上限值	0.0~100.0%	100.0	
Pr7-04	PID 輸出頻率限制	0.0~100.0%	100.0	
Pr7-05	PID 偏移量	-100.0~+100.0%	0.0	
Pr7-06	PID 濾波延遲時間	0.000~0.100 Sec	0.000	
Pr7-07	PID 回授訊號異常檢出時間	0.0~6000.0 Sec	0.0	
Pr7-08	PID 回授訊號錯誤處置方式	0 警告但繼續運轉	0	
		1 警告且減速停止		
		2 警告且滑行停止		
Pr7-09	操作器 (PU) 斷線處置方式 (選配)	0 警告且減速停止	0	
		1 警告且滑行停止		
Pr7-10	操作器 (PU) 斷線逾時檢出 (選配)	0.0：不檢出且繼續運轉	0.0	
		0.1~60.0 Sec		
Pr7-11	RS-485 串列通訊埠位址 (選配)	1~254	1	
Pr7-12	RS-485 串列通訊埠傳輸速率 (選配)	1.2~125 k bps (位元 / 秒)	9.6	
Pr7-13	RS-485 串列通訊埠傳輸錯誤處置 (選配)	0 警告但繼續運轉	3	
		1 警告且減速停止		
		2 警告且滑行停止		
		3 不警告且繼續運轉		
Pr7-14	RS-485 串列通訊埠傳輸逾時檢出 (選配)	0.0：無傳輸逾時檢出	0.0	
		0.1~60.0 Sec		
Pr7-15	RS-485 通訊協定 (選配)	0：7，N，2 ASCII	0	
		1：7，E，1 ASCII		
		2：7，0，1 ASCII		
		3：7，E，2 ASCII		
		4：7，0，2 ASCII		
		5：8，N，1 ASCII		
		6：8，N，2 ASCII		
		7：8，E，1 ASCII		
		8：8，0，1 ASCII		
		9：8，E，2 ASCII		
		10：8，0，2 ASCII		
		11：8，N，1 RTU		
		12：8，N，2 RTU		
		13：8，E，1 RTU		
		14：8，0，1 RTU		
		15：8，E，2 RTU		
16：8，0，2 RTU				

8 參數群：風機，水泵控制相關參數

參數	參數功能	設定範圍		出廠值	客戶
		0	1		
★ Pr8-00	V/F 曲線選擇	0	V/F 曲線由參數群 1 設定	0	
		1	1.5次方曲線		
		2	2次方曲線		
Pr8-01	輔助電動機啟動頻率	0.00~600.00Hz		0.00	
Pr8-02	輔助電動機停止頻率	5.00~600.00Hz		5.00	
Pr8-03	輔助電動機啟動延時	0.0~6000.0Sec		0.0	
Pr8-04	輔助電動機停止延時	0.0~6000.0Sec		0.0	
Pr8-05	睡眠頻率	0.00~600.00Hz		0.00	
Pr8-06	甦醒頻率	0.00~600.00Hz		0.00	
Pr8-07	睡眠時間	0.0~6000.0 Sec		0.0	

錯誤訊息指示與故障排除

變頻器本身有過電壓，低電壓及過電流等多項警示訊息及保護功能，一旦異常故障發生，保護功能動作，變頻器停止輸出，電動機滑行停止。異常原因會顯示於數位操作器，同時異常接點輸出端子動作，請依變頻器之異常顯示符號對照其異常原因及處置方法。異常記錄會儲存在變頻器內部記憶體（可記錄最近 16 次異常訊息），可由數位操作器讀出也可經通信方式讀取。而當發生警告機能動作時，僅數位操作器上閃爍顯示警告內容（有些例外），異常接點輸出端子不動作。

變頻器由 IC，電阻，電容，電晶體等電子零件及冷卻風扇等為數眾多的零件組成。這些零件不是能夠永久不壞，不是可以永久使用，即使在正常環境運用，若超過其耐用年限，則容易發生故障。因此要實施預防性定期檢查，把不符合規格要求或已有品質不良品發掘出來，及早摒除會造成變頻器不良之潛在原因。同時也把逾期耐用年限的各部品趁機會換掉，以確保良好可安全地運轉，平常就需要從外部目視檢查變頻器的運轉，確認沒有異常狀況發生，並檢查是否有下列警示訊息發生。

異常跳脫復歸：

由異常跳脫狀態，消除警報原因後，可按面板上的復歸鍵執行異常復歸，或將外部端子設定為”異常復歸指令”並導通此端子執行異常復歸或以通訊方式傳送異常復歸指令，便可解除異常跳脫狀態。任何異常警報解除前，應使運轉信號為斷路(OFF)狀態，以防止異常訊號復歸後立即重新運轉而導致機械損害或人員傷亡。

請注意：異常發生後，必須先將異常狀況排除，再等待 5 秒後(oC、GF、SC異常需等待15秒後)按RESET 鍵才能有效復歸。

異常訊息及排除方法

顯示符號	異常現象說明 (符號字元) {異常碼}	排除方法
oC	輸出側過電流 (oC) {01}	<ul style="list-style-type: none"> ◆ 檢查與電動機連接線是否有短路現象或接地 ◆ 延長加速時間(Pr1-11, Pr1-12) ◆ 檢查電動機額定與變頻器額定是否相匹配 ◆ 檢查變頻器與電動機的螺絲有無鬆動 ◆ 檢查電動機是否有超額負載 ◆ 是否驅動特殊馬達(高速馬達或脈衝馬達) ◆ 異常排除需等待15秒後，按RESET鍵才能有效復歸
oU	DC-bus過電壓 (oU) {02}	<ul style="list-style-type: none"> ◆ 檢查電源電壓是否在變頻器額定輸入電壓範圍內，並監測是否有突波電壓產生 ◆ 若是由於電動機慣量回升電壓，造成變頻器內部直流高壓側電壓過高，可加長減速時間或加裝煞車器及煞車電阻(選配)

oUd	減速時DC-bus過電壓 (oUd) {37}	<ul style="list-style-type: none"> ◆ 檢查電源電壓是否在變頻器額定輸入電壓範圍內，並監測是否有突波電壓產生 ◆ 電動機慣量回升電壓，造成變頻器內部直流高壓側電壓過高，可加長減速時間或加裝煞車器及煞車電阻(選用)
GF	輸出側對地漏電 (GF) {03} 變頻器偵測到輸出端對地漏電且接地電流高於變頻器額定電流的50%以上。 注意:此保護係針對變頻器而非人體	<ul style="list-style-type: none"> ◆ 檢查與電動機連線是否有短路現象或接地 ◆ 確定IGBT功率模組是否損壞 ◆ 檢查輸出側接線是否絕緣不良 ◆ 異常排除需等待15秒後，按RESET鍵才能有效復歸
SC	IGBT模組異常 (SC){04} 變頻器偵測到 IGBT 模組異常	<ul style="list-style-type: none"> ◆ 檢查電動機的阻抗及絕緣是否正常 ◆ 檢查與電動機連接線是否有短路現象 ◆ 將變頻器的電動機連接線切斷後若仍發生則確定IGBT功率模組異常--送廠維修 ◆ 異常排除需等待15秒後，按RESET鍵才能有效復歸
oL	變頻器過載 (oL){05} 輸出電流長時間超過可承受的電流額定電流的150 %可承受60秒	<ul style="list-style-type: none"> ◆ 減輕負載及延長加速時間 ◆ 檢查電動機是否過負載 ◆ 減低(Pr5-01) 轉矩提升設定值 ◆ 選用較大輸出容量變頻器
oL1	電動機1 過負載 (oL1) {06} (電子熱動電驛1保護動作)	<ul style="list-style-type: none"> ◆ V/F 1曲線設定是否適當 ◆ 是否長時間低速運轉 ◆ 檢查電動機1是否過載 ◆ 檢查(Pr5-00) 電動機1額定電流值是否適當 ◆ 檢查電子熱動電驛1功能設定(Pr5-18~ Pr5-19) ◆ 增加電動機1容量
ot1	過轉矩1檢出動作 (ot1) {07}	<ul style="list-style-type: none"> ◆ 檢查電動機1負載是否過大 ◆ 檢查(Pr5-00) 電動機1額定電流值是否適當 ◆ 檢查過轉矩檢出位準1設定值(Pr5-15~Pr5-17) ◆ 機械負載是否異常 ◆ 增加電動機1容量，選用較大輸出容量變頻器
oCn	恆速運轉中輸出側過電流 (oCn) {08}	<ul style="list-style-type: none"> ◆ 輸出連接線是否絕緣不良 ◆ 檢查電動機是否堵死 ◆ 更換較大輸出容量的變頻器
oCA	加速時輸出側過電流 (oCA) {09}	<ul style="list-style-type: none"> ◆ 檢查變頻器與電動機的螺絲有無鬆動 ◆ 檢查輸出連接線是否絕緣不良 ◆ 延長加速時間 ◆ 減低(Pr5-01) 轉矩提升設定值 ◆ 更換較大輸出容量的變頻器
oCd	減速時輸出側過電流 (oCd) {10}	<ul style="list-style-type: none"> ◆ 輸出連接線是否絕緣不良 ◆ 延長減速時間 ◆ 更換較大輸出容量的變頻器
EP1	EEPROM記憶體資料讀出異常 (EP1) {11}	<ul style="list-style-type: none"> ◆ 待顯示幕熄滅後再重新上電 ◆ 將參數復歸為出廠設定，若無效則送廠維修

EP2	EEPROM記憶體資料寫入異常 (EP2) {12}	
EF	外部異常輸入動作 (EF) {13} (Pr2-01~Pr2-03 之一=14 且作動)	◆ 清除外部故障來源後執行RESET命令即可復歸
Ct1	U 相電流傳感迴路或CPU板A/D轉換迴路異常 (Ct1) {14}	◆ 將變頻器的電源切斷後待顯示幕熄滅後再重新上電後若再次出現異常則送廠維修 ◆ 更換控制板或U 相電流傳感器
Ct2	W 相電流傳感迴路或CPU板A/D轉換迴路異常 (Ct2) {15}	◆ 將變頻器的電源切斷後待顯示幕熄滅後再重新上電後若再次出現異常則送廠維修 ◆ 更換控制板或W 相電流傳感器
HPF	硬體保護迴路異常 (HPF) {16}	◆ 將變頻器的電源切斷後待顯示幕熄滅後再重新上電後若再次出現異常則送廠維修
oH1	IGBT模組內部或散熱器溫度過高 (oH1) {17}	◆ 檢查風扇動作是否正常 ◆ 檢查環境溫度是否過高 ◆ 檢查散熱器是否有異物或油污覆蓋 ◆ 檢查散熱風道是否暢通 ◆ 檢查是否有足夠散熱空間及足夠冷空氣對流
oH2	變頻器箱體週溫過高 (oH2) {18} (或其它特定監測點溫度超過容許值)	◆ 檢查風扇動作是否正常 ◆ 檢查環境溫度是否過高 ◆ 檢查是否有足夠散熱空間及足夠冷空氣對流
Soft	預充電限流迴路異常 (Soft) {19}	◆ 將變頻器的電源切斷後待顯示幕熄滅後再重新上電後若再次出現異常則送廠維修
ASC	RS485串列埠通訊傳輸逾時 (ASC) {21}	◆ 檢查RS-485配線
PI.d	PID回授訊號異常 (PI.d) {22}	◆ 檢查PID回授配線 ◆ 檢查PID參數是否設定恰當
Pu	操作器(PU)斷線逾時 (Pu) {23}	◆ 檢查Keypad連接線
tunE	電動機參數調適失敗 (tunE) {24}	◆ 檢查電動機接線是否正確 ◆ 變頻器的輸出容量與電動機容量是否懸殊 ◆ 重新檢查配線及參數後再執行
bF	動能煞車迴路異常 (bF) {25}	◆ 將變頻器的電源切斷後待顯示幕熄滅後再重新上電後若再次出現異常則送廠維修
PHL	變頻器內部DC-Bus連波電壓過高 (電源欠相) (PHL) {27}	電源輸入異常所引起: ◆ 檢查電源電壓是否正常 ◆ 檢查電源三相電壓是否平衡 ◆ 檢查電源輸入端點螺絲是否鎖緊 ◆ 是否三相電源機種只接單相電源或欠相 直流濾波電容異常所引起: ◆ 檢查直流濾波電容是否已老化
CC	停機中電流訊號異常, 電流偵測硬體電路異常 (CC) {28}	◆ 若偶而發生且復歸後即恢復正常, 為雜訊干擾, 若無效則送廠維修
CPu	變頻器偵測線路異常 (CPu) {29}	◆ 將變頻器的電源切斷後待顯示幕熄滅後再重新上電後若再次出現異常則送廠維修

FAn	散熱風扇異常 (FAn) {30}	<ul style="list-style-type: none"> ◆ 檢查風扇是否被堵住 ◆ 更換風扇
An1	類比輸入信號異常 (AnI.) {31}	<ul style="list-style-type: none"> ◆ 檢查類比輸入信號是否超出範圍
ot2	過轉矩2檢出動作 (ot2) {32}	<ul style="list-style-type: none"> ◆ 檢查電動機2負載是否過大 ◆ 檢查(Pr5-40) 電動機2額定電流值是否適當 ◆ 檢查過轉矩檢出位準1設定值(Pr5-21~Pr5-23) ◆ 機械負載是否異常 ◆ 增加電動機2容量, 選用較大輸出容量變頻器
oL2	電動機2 過負載 (oL2) {33} (電子熱動電驛2保護)	<ul style="list-style-type: none"> ◆ V/F 2曲線設定是否適當 ◆ 是否長時間低速運轉 ◆ 檢查電動機2是否過載 ◆ 檢查(Pr5-40) 電動機1額定電流值是否適當 ◆ 檢查電子熱動電驛1功能設定(Pr5-45~ Pr5-46) ◆ 增加電動機2容量
rnot	電動機切換異常 (rnot) {34}	<ul style="list-style-type: none"> ◆ 檢查電動機接線是否正確 ◆ 檢查參數設定是否正確
LUr	運轉中DC-bus低電壓 (LUr) {36}	<ul style="list-style-type: none"> ◆ 檢查輸入電源電壓及配線是否正常 ◆ 檢查電源容量及電源系統是否不足 ◆ 檢查負載是否有突然的重載 ◆ 是否三相電源機種只接單相電源或欠相
LU	DC-bus低電壓 (LU) {39}	<ul style="list-style-type: none"> ◆ 檢查輸入充電限流迴路是否正常 ◆ 檢查運轉中輸入電源是否中斷 ◆ 電源側電磁接觸器是否不良或故障 ◆ 同一電源系統中是否有大容量馬達起動
bb	外部中斷 (bb) {40}	<ul style="list-style-type: none"> ◆ 當外部多功能輸入端子(MI1~MI3=15或16)有設定此外部中斷功能動作時, 變頻器停止輸出, 清除外部中斷信號後”bb”立刻消失

外觀尺寸

Unit: mm(inch)

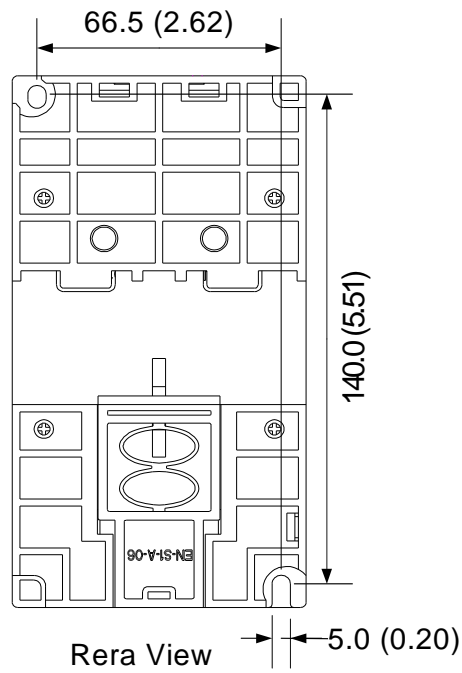
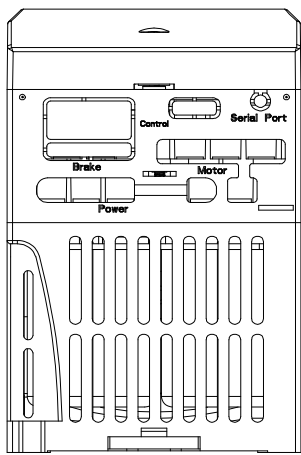
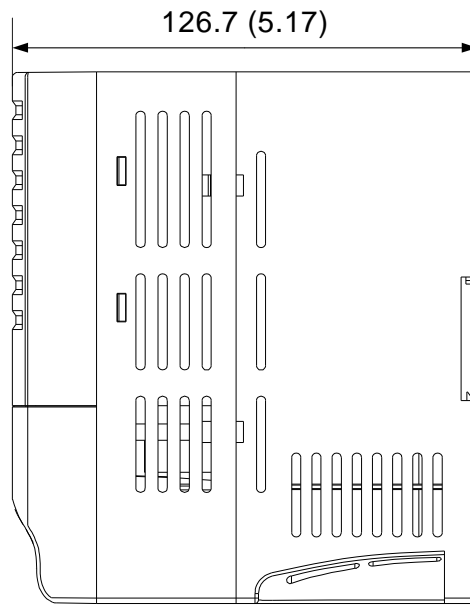
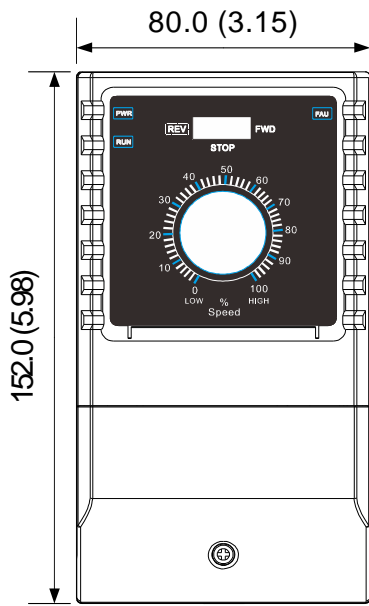

陽岡科技股份有限公司
TOPTEK ELECTRONICS CORPORATION

台灣省 桃園縣 中壢市 自強六路1號 (中壢工業區)
No.1, Tzu-Chiang 6 Road,
Chung-Li City, Taoyuan Hsien
Taiwan

Tel: +886-3-462-9199 Fax: +886-3-462-8829
<http://www.toptek.biz> E-mail: tt@toptek.biz

ML-QSL101

Date Code:3116