



TOPTEK ELECTRONICS CORPORATION

TOPVERT G1 series

TOPVERT H1 series

TOPVERT P1 series

QUICK START

快速安裝手冊

High performance Vector Control AC drive

高性能 向量控制 變頻器

ISO 9001:2008



PREFACE

Thank you for choosing TOPTEK'S TOPVERT G1, H1 and P1 Series Drive. TOPVERT G1, H1 and P1 Series are Sensorless current vector control high-performance drive. They were manufactured by adopting high-quality components, material and incorporating the latest microprocessor technology available.

Copyright statement

All information in this Quick start manual are Toptek's intellectual property. Even we had done our best to make this manual but is unable to guarantee 100% correct. Based on " Never Stop for better but perfect accomplished " quality policy, our product permanently in the journey which perfectly strives for perfection to the pursue, Therefore we reserve the right to change the information in this manual without prior notice. But we will continue the latest edition document in our website, for free download.

<http://www.toptek.biz>

Getting Started

This manual will be helpful in the installation, parameter setting, troubleshooting, and daily maintenance of the drives. To guarantee safe operation of the equipment, read the following safety guidelines before connecting power to the drives. Keep this operating manual handy and distribute to all users for reference.



 Always read this manual thoroughly before using TOPVERT G1, H1 and P1 Series drives.

 **DANGER!**

- 1- AC input power must be disconnected before any maintenance. Do not connect or disconnect wires and connectors while power is applied to the circuit. Maintenance must be performed by qualified technicians.
- 2- A charge may still remain in the DC-link capacitor with voltages even if the power has been turned off. To avoid personal injury, please ensure that power has turned off before operating drive and wait ten minutes for capacitors to discharge to safe voltage levels.
- 3- The drive may be destroyed beyond repair if incorrect cables are connected to the input/output terminals. Never connect the drive output terminals U/T1, V/T2, and W/T3 directly to the AC main circuit power supply

 **CAUTION!**

- 1- There are highly sensitive MOS components on the printed circuit boards. These components are especially sensitive to static electricity. To avoid damage to these components, do not touch these components or the circuit boards with metal objects or your bare hands.
- 2- Ground the drive using the ground terminal. The grounding method must comply with the laws of the country where the drive is to be installed. Refer to Basic Wiring Diagram.
- 3- The final enclosures of the drive must comply with EN50178. (Live parts shall be arranged in enclosures or located behind barriers that meet at least the requirements of the Protective Type IP20. The top surface of the enclosures or barrier that is easily accessible shall meet at least the requirements of the Protective Type IP40). (TOPVERT G1, H1 and P1 Series correspond with this regulation.)
- 4- Heat sink may heat up over 70°C (158°F), during the operation. Do not touch the heat sink.
- 5- The rated voltage for the drive must be $\leq 240\text{V}$ ($\leq 480\text{V}$ for 460V models, $\leq 600\text{V}$ for 575V models) and the mains supply current capacity must be $\leq 5000\text{A RMS}$ ($\leq 10000\text{A RMS}$ for the $\geq 40\text{hp}$ (30kW) models).
- 6- The leakage current between chassis and earth could be up to 22mA.
- 7- The load motor should meet IEC:60034-1 standard.

Nameplate Information

Example for G1 series, 3HP/2.2kW 230V 3-Phase, a speed feedback PG card equipped.

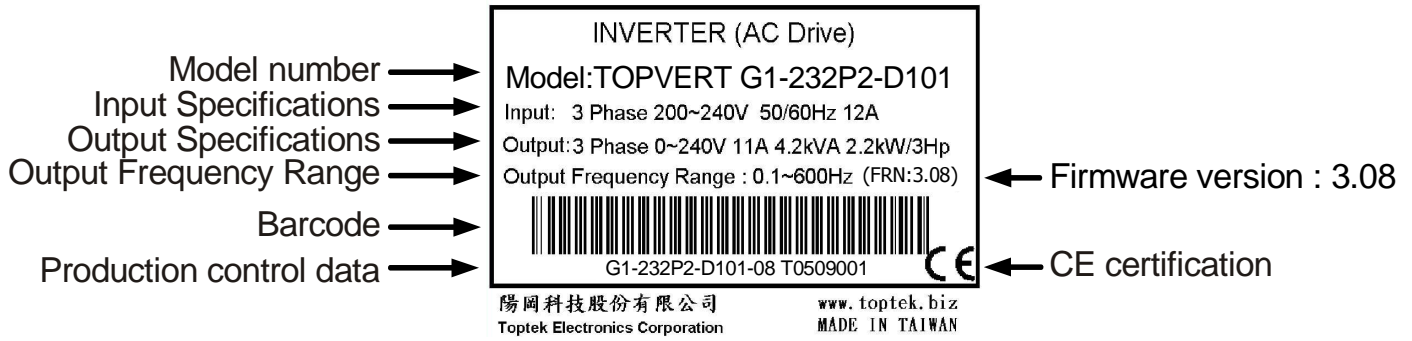

Model Explanation

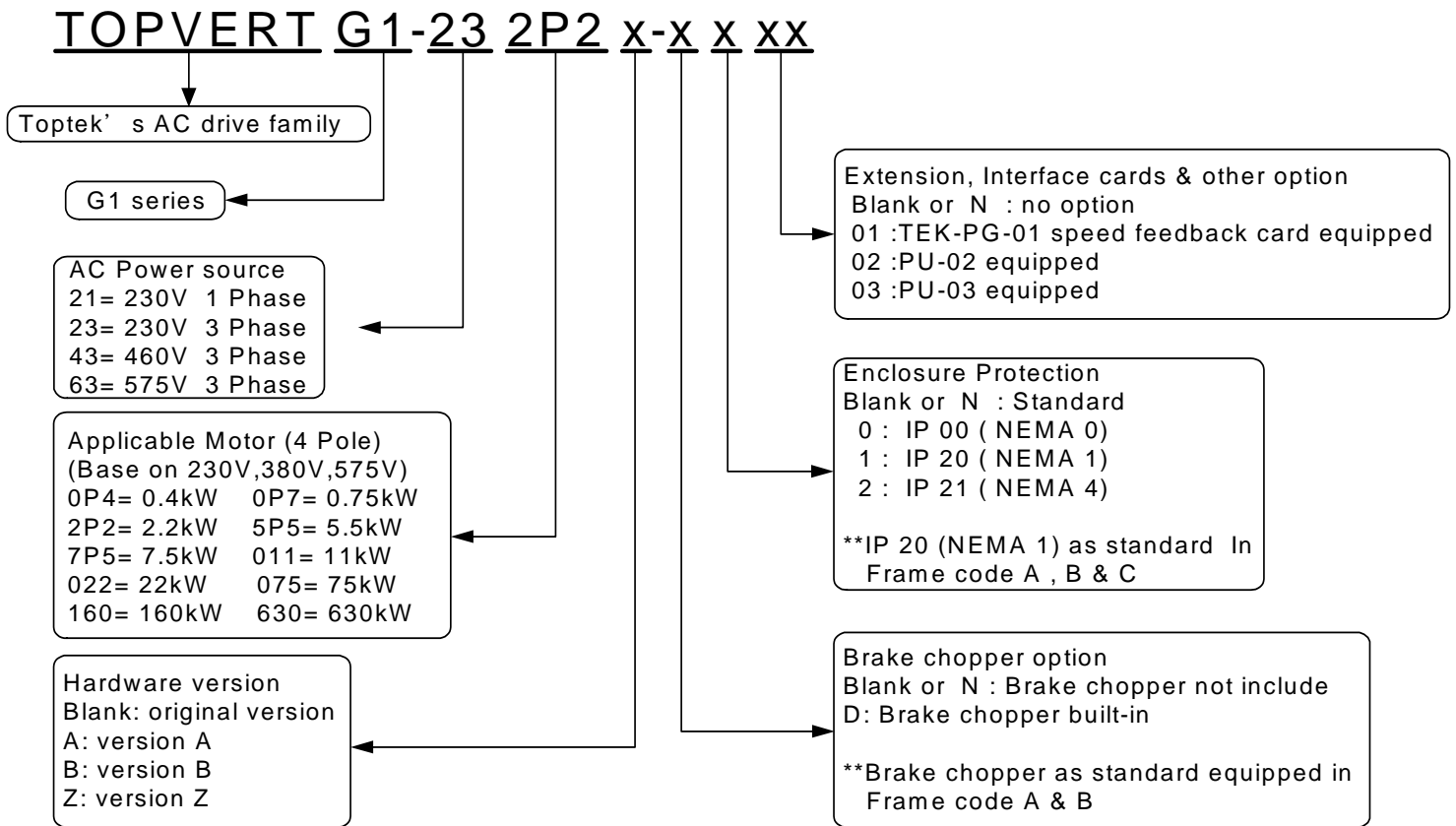

Explanation of Production control data

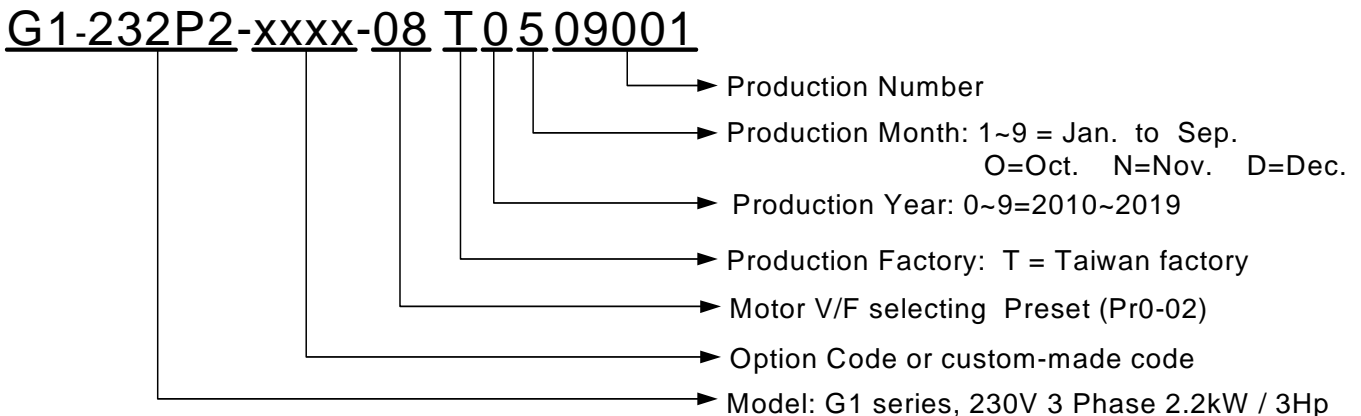

● Please contact the dealers immediately if any discrepancy occurred.

STANDARD SPECIFICATIONS

Series	TOPVERT G1 series High performance general purpose multi-function drive	TOPVERT H1 series High performance high speed drive	TOPVERT P1 series High performance variable torque drive for Fan & Pump	
Control Characteristics	Output frequency range	0.1 - 600Hz, Programmable	0.1 - 6000Hz, Programmable	
	Overload endurance	150% of rated current for 1 minute/10 minutes, Ta <=40, 200% of rated current for 2 seconds	125% of rated current for 1 minute/10 minutes, Ta <=40, 165% of rated current for 2 seconds	
	Maximum output voltage	Proportional to Input Voltage, 3-Phase output		
	Power factor/Efficiency	Power factor no lower than 0.95. Efficiency no lower than 95% at full load		
	Control system	SPWM (Sinusoidal Pulse Width Modulation) vector control, 4 control modes :V/F, V/F + PG, SVC & VC + PG		
	Speed control range	V/F mode 20:1; V/F+PG mode 120:1; SVC mode 120:1; VC+PG mode 600:1		
	Output frequency resolution	Analog input: 10Bit(1/1024), Digital input: 0.01Hz, Fly-Shuttle dial input: 0.01Hz		
	Output frequency accuracy	Analog input: Within ±0.2% of max. output frequency (25°C ±10°C). Digital input: Within 0.01% of set output frequency		
	PWM carrier Frequency	0.7 -18kHz, Adjustable (Some models are limited), H1: 1.4kHz ~ 36kHz, Adjustable		
	Torque characteristics	auto-torque boost, auto-slip compensation; starting torque can be 150% at 1.0Hz		
	Skip frequency	Setting range 0.00 -600Hz (H1series: 0.00 ~ 6000 Hz), Max. 6 points, skip width are adjustable		
	Accel/Decel time	0.1-60000 seconds (2 Independent settings for Accel/Decel Time)		
	Stall prevention	0 to 250% of Rated Current, independent adjustable both in acceleration and constant speed operation.		
	DC Braking	DC Braking both when start up and stop , Braking Current Level: 0 to 125% of rated output current. Braking time: 0 to 60 seconds. Braking Start-Point when stop: 0.1-600Hz (H1series: 0.00 ~ 6000 Hz)		
	OPERATING Characteristics	Frequency Setting	Keypad	By an Encoder style Fly-Shuttle dial. (setting resolution 0.01Hz/0.1Hz/1Hz/10Hz adjustable)
External Signal			0 ~ +10VDC((Input impedance 20kΩ), -10 ~ +10VDC((Input impedance 10kΩ), 4 ~20mA DC ((Input impedance 250Ω), Multi-Function Inputs 1 ~ 6 (15 Steps Jog, up/down), PLC run, RS-485 port MODBUS protocol	
Operation Setting		Keypad	Set by RUN, STOP and JOG. Switch-able between Keypad and External signal	
		External Signal	2 wire control(FWD/STOP · REV/STOP · RUN/STOP · FWD/REV), 3 wire control, FWD, REV, M1 to M16 can be combined to offer various modes of operation, RS-485 serial interface MODBUS protocol	
Multi-Function Digital Input (DI) (6 terminals)		Multi-step selection 0 to 15, first to second accel/decel switches, accel/decel inhibit, Input the counter, Pause Stop, EF Input, Emergency Stop, auxiliary motor control is invalid, ACI/AVI/AUI speed command selection, Reset, PLC Run, Jog, Up/Down command, Sink/Source selection, Parameter team selection...etc, up to 43 functions.		
Multi-Function Output Indication (DO) (4 indications)		Include a form C relay contact, a form A relay contact and 2 Open collector output. They can be programmed to below indications: Drive Operating, Frequency Attained, zero speed, Base Block, Over torque, Fault Indication, Local/Remote indication, PLC Operation indication, and Auxiliary Motor Output, Drive ready for use, IGBT over-heat indication ...etc, up to 63 functions.		
Multi-Function Analog Input (AI)		AVI: 0 ~ +10VDC((Input impedance 20kΩ), AUI: -10 ~ +10VDC((Input impedance 10kΩ), ACI: 4 ~20mA DC ((Input impedance 250Ω). 3 different Input terminals can be programmed to 15 functions		
Multi-Function Analog Output (AO)		Include ACO and AVO, They can be programmed to Proportional to output frequency, output current, voltage, frequency command or motor's speed ...etc, up to 15 functions.		
Fault Indication		The output will be activated when faults occur (User may get 1 or up to 4 indications from below terminals: 2 Relay contact point RA, RB, RC, or 2 Open-collector		
Communication function		RS-485 serial port, MODBUS protocol, ASCII & RTU. (Baud rate up to 125 k bps)		
Other Functions		PID feedback control, Flying start, Automatic voltage regulation (AVR), 2 accel./decel time selection , Auto-optimum accel./decel. Time, S-curves, External fault interlock, External fault reset, Auto Restart after fault, 16 Fault records, Automatic energy-saving, Upper/Lower limit, Programmable pulse output, Password protection, Pump and Fan process control, Sleep/Wakeup function , Auto-Tuning, By-Pass, Y-Delta control, Bi-Directional Speed search, Reverse inhibit, Automatic torque boost & slip compensation, 16-step PLC run, 16 step preset speed, Coast or ramp to stop, Random V/F curve, Mechanical brake release control, IGBT/ Heatsink temperature display & Pre-warning, Quiet operation mode (No noise), User define Multi-function display, Over torque detection, Over current/voltage t stall prevention, Sink/Source (NPN/PNP) mode, Electronic Thermal Relay, Internal Counter, DC injection brake both in start and stop, Dynamic brake, Controlled cooling Fan, Removable keypad operator, Programmable Multi-Function DI, DO, AI, AO and Ry terminals.		
Intelligent Protection Functions		Self-testing, AC source Over Voltage, Phase loss, Over Voltage, Over Current, Under Voltage, Over Torque, External Fault, Motor over-load, IGBT Over-temperature, Heat-sink Over-temperature, Electronic thermal, Ground Fault, Output short circuit, Stall Prevention, Fuse protection, IGBT short circuit , Drive Over Load , DC bus capacitor life monitoring, Auto carrier frequency adjust according temperature, 16 Trip records, Run information of latest Fault such like DC-BUS voltage, Output voltage/Frequency/Current, Command frequency, IGBT temperature, Heat-sink temperature....etc.		
Digital Keypad (PU-02 Digital Keypad with copy function and PU-03 Digital Keypad with LCD display are available as an option)		<p>Eight Function keys: Access R un, Stop, Reset/ Digit Shift, Forward/ Reverse run, Display mode, Keypad Enable, Programming data and Jog operation...etc.</p> <p>One Encoder style Fly-Shuttle dial: Sets the parameter number and changes the numerical data</p> <p>One 6 digits 7 segment display: Display the Setting frequency/actual operation frequency, Output current/Voltage, motor speed, Fault trip User defined unit(up to 88 type)...etc.</p> <p>Six LED Display for status indication: Display the Drive run/stop status, Forward/Reverse run status, Keypad enable, and Frequency command source.</p> <p>One RJ-45 connector: Removable Keypad, remote control distance up to 150 meters.</p>		
Environment		Certificate	Complies with CE (EN61800-3) standard	
		Temperature	Ambient: -10°C ~ +40°C/(-10°C ~ +50°C) (Non-Condensing and not frozen). Storage: -20°C ~ +60°C	
	Humidity	Below 98% R.H. (Non-Condensing)		
	Vibration	Below 20Hz: 1G, above 20Hz: 0.6G		
	Installation Location	Altitude 1,000 m or lower, keep away from corrosive gasses, liquid and dust		

* All series in TOPVERT family are designed and manufactured base on CNS and IEC, IEEE, CE & UL standard.

TOPVERT G1, H1 Series: 1-Phase, 200/-15% ~ 240/+10%Vac, 47 ~ 63Hz [400Hz]											
Model	Applicable Motor (230V 4 P)		Rated Output				Source	Enclosure structure			
	Power (kW)	Horse Power (Hp)	Capacity (kVA)	Current (A)	Voltage (V)	Frequency (Hz)		Current (Amax.)	Cooling Method (Noise level)	Degree of protection	Net Weight (kg)
TOPVERT G1-xxxxx H1-xxxxx											
210P4	0.4	0.5	1.2	3	3- Phase, 0-100% of supply voltage	G1 series 0 ~ 600	5.7	Fan- cooled (<70 dB/1M)	IP 20 NEMA 1 [IP 21/40/42 /50/52 Optional]	2.6	G1-A H1-A
210P7	0.75	1	2	5			9.5			2.7	
211P5	1.5	2	3	7.5		H1 series 0 ~ 6000	14			2.7	
212P2	2.2	3	4.4	11			21			3.0	

TOPVERT G1, H1 Series: 3-Phase, 200/-15% ~ 240/+10%Vac, 47 ~ 63Hz [400Hz]												
Model	Applicable Motor (230V 4 P)		Rated Output				Source	Enclosure structure				
	Power (kW)	Horse Power (Hp)	Capacity (kVA)	Current (A)	Voltage (V)	Frequency (Hz)		Current (Amax.)	Cooling Method (Noise level)	Degree of protection	Net Weight (kg)	Frame Code
TOPVERT G1-xxxxx H1-xxxxx												
230P4	0.4	0.5	1.2	3	3- Phase - 0-100% of supply voltage	G1 series : 0 ~ 600	3.3	Fan- cooled (<70 dB/1M)	IP 20 NEMA 1 [IP 21/40/ 42/50/52 Optional]	2.6	G1-A H1-A	
230P7	0.75	1	2	5			5.5			2.8		
231P5	1.5	2	3	7.5			8.3			2.8		
232P2	2.2	3	4.4	11			12			2.8		
233P7	3.7	5	6.8	17			19			3.0		
235P5	5.5	7.5	10	25			28			3.2		
237P5	7.5	10	13	33			36			4.0		G1-B H1-B
23011	11	15	20	49			54			11.9		G1-C H1-C
23015	15	20	26	65			72			12.3		
23018	18.5	25	30	75			83			13.0		
23022	22	30	36	90			99			13.5		G1-D H1-D G1-E G1-F H1-F
23030	30	40	48	120			132			32.7		
23037	37	50	58	145		160	33.8					
23045	45	60	73	182		200	34.6					
23055	55	75	92	232		255	58.0					
23075	75	100	120	300		330	59.4					
23090	90	125	143	360		396	192	G1-G				
23110	110	150	175	440		484	192					
23132	132	175	207	520		572	198					
23132S	132	175	207	520			572	Fan- cooled (<80 dB/1M)	[IP 20/21 /40/42/ 50/52 NEMA 1 Optional]	302	G1-H Free-st anding	

[]: Optional

TOPVERT G1, H1 Series: 3-Phase 380/-15% ~ 480/+10%Vac, 47 ~ 63Hz/[400Hz]													
Model	Applicable Motor (4 pole)		Rated Output				Source	Enclosure structure					
	380/415 V (kW/Hp)	440/460 V (kW/Hp)	Capacity (kVA)	Current (A)	Voltage (V)	Frequency (Hz)		Current (A)	Cooling Method (Noise level)	Degree of protection	Net Weight (kg)	Frame Code	
TOPVERT G1-xxxxx H1-xxxxx													
430P7	0.75/1		2.4	3	3-Phase - 0-100% of supply voltage	G1 series : 0 ~ 600	3.3	Fan-cooled (<70 dB/1M)	IP 20 NEMA 1	2.8	G1-A H1-A		
431P5	1.5/2		3.3	4.2			4.6			2.9			
432P2	2.2/3		4.8	6			6.6			2.9			
433P7	3.7/5		6.8	8.5			9.4			2.9			
435P5	5.5/7.5		10	13			14			3.0			
437P5	7.5/10		14	18			20			3.3			
43011	11/15		19	24			26			4.3	[IP 21 /40/42/ 50/52 Optional]	G1-B H1-B	
43015	15/20		25	32			35			5.0			
43018	18.5/25		32	40			44			13.0			
43022	22/30		38	48			53			13.0	G1-C H1-C		
43030	30/40		48	60			66			13.9			
43037	37/50		64	80			88			13.9			
43045	45/60		77	97			107			13.9			
43055	55/75	75/100	94	118			130			33.5		IP 00 NEMA 0	G1-D H1-D
43075	75/100	90/125	121	152			167			37.1			
43090	90/125	110/150	143	180			198	42.4	[IP 20/21 /40/42/ 50/52 NEMA 1 Optional]	G1-E H1-E			
43110	110/150	132/175	191	240			264	63.0					
43132	132/175	160/215	215	270			297	64.5			G1-F H1-F		
43160	160/215	185/250	242	304			334	64.5					
43185	185/250	220/300	295	370			407	192					
43220	220/300	280/375	359	450			495	192	G1-G				
43280	280/375	315/422	414	520			572	198					
43315	315/422	375/500	486	610			671	198					
43280S	280/375	315/422	414	520			572	302	Fan-cooled (<80 dB/1M)	IP 20 NEMA 1	G1-H Free-standing		
43315S	315/422	375/500	486	610			671	312					
43400S	400/535	450/600	583	732			805	333					
43450S	450/600	500/670	690	866			953	341	[IP 21 /40/42/ 50/52 Optional]				
43500S	500/670	560/750	766	962			1058	348					
43560S	560/750	630/850	872	1094			1203	355					
43630S	630/850	750/1000	966	1212			1333	360					

[]: Optional

TOPVERT P1 Series : 3-Phase , 200/-15% ~ 240/+10%Vac, 47 ~ 63Hz /[400Hz]											
Model	Applicable Motor (230V 4 P)		Rated Output				Source	Enclosure structure			
TOPVERT P1-xxxxx	Power (kW)	Horse Power (Hp)	Capacity (kVA)	Current (A)	Voltage (V)	Frequency (Hz)	Current (Amax.)	Cooling Method (Noise level)	Degree of protection	Net Weight (kg)	Frame Code
230P7	0.75	1	1.4	3.6	3-Phase - 0-100% of supply voltage	0 ~ 600	4	Fan-cooled (<70 dB/1M)	IP 20 NEMA 1	2.6	P1-A
231P5	1.5	2	2.4	6			6.6			2.8	
232P2	2.2	3	3.6	9			9.9			2.8	
233P7	3.7	5	5.3	13.2			15			2.8	
235P5	5.5	7.5	8.1	20.4			22			3.0	
237P5	7.5	10	12	30			33			3.2	
23011	11	15	16	39.6			44		4.0	P1-B	
23015	15	20	23	58.8			65		11.9	P1-C	
23018	18.5	25	31	75			86		12.3		
23022	22	30	36	90			99		13.0		
23030	30	40	43	108			119		13.5		
23037	37	50	57	144			158		32.7	P1-D	
23045	45	60	69	174			191		33.8		
23055	55	75	87	218.4			240		34.6		
23075	75	100	111	278.4			306	58.0	P1-F		
23090	90	125	143	360			396	59.4			
23110	110	150	172	432			475	192	P1-G		
23132	132	175	210	520			581	192			

[]: Optional

TOPVERT P1 Series : 3-Phase,380/-15% ~ 480/+10%Vac, 47 ~ 63Hz/[400Hz]											
Model	Applicable Motor (4 pole)		Rated Output				Source	Enclosure structure			
	380/415 V (kW/Hp)	440/460 V (kW/Hp)	Capacity (kVA)	Current (A)	Voltage (V)	Frequency (Hz)		Current (Amax.)	Cooling Method (Noise level)	Enclosure	Net Weight (kg)
TOPVERT P1-xxxx											
431P5	1.5/2		2.9	3.6	3-Phase - 0-100% of supply voltage	0 ~ 600	4	Fan-cooled (<70 dB/1M)	IP 20 NEMA 1	2.8	P1-A
432P2	2.2/3		4	5.04			5.5			2.9	
433P7	3.7/5		5.7	7.2			7.9			2.9	
435P5	5.5/7.5		8.1	10.2			11			2.9	
437P5	7.5/10		12	15.6			17			3.0	
43011	11/15		17	21.6			24			3.3	
43015	15/20		23	28.8			32			4.3	P1-B
43018	18.5/25		31	38.4			42			5.0	
43022	22/30		38	48			53			13.0	
43030	30/40		46	57.6			63			13.0	P1-C
43037	37/50		57	72			79			13.9	
43045	45/60		76	96			106			13.9	
43055	55/75		93	116.4			128			13.9	P1-D
43075	75/100	90/125	113	141.6			156			33.5	
43090	90/125	110/150	145	180			201			37.1	
43110	110/150	132/175	172	216			238	42.4	P1-E		
43132	132/175	160/215	229	270			317	63.0	P1-F		
43160	160/215	185/250	258	304			356	64.5			
43185	185/250	220/300	291	365			401	64.5			
43220	220/300	280/375	354	444			488	192	P1-G		
43280	280/375	315/422	430	520			594	192			
43315	315/422	375/500	497	610			671	198			
43400	400/535	450/600	583	732			805	198	P1-H Free-standing		
43315S	315/422	375/500	497	610			671	312			
43400S	400/535	450/600	583	732			805	333			
43450S	450/600	500/670	700	866			953	341	P1-H Free-standing		
43500S	500/670	560/750	828	962			1058	348			
43560S	560/750	630/850	920	1094			1203	355			
43630S	630/850	750/1000	1046	1212			1333	360			

[]: Optional

Basic Wiring Diagram

Wiring Diagram

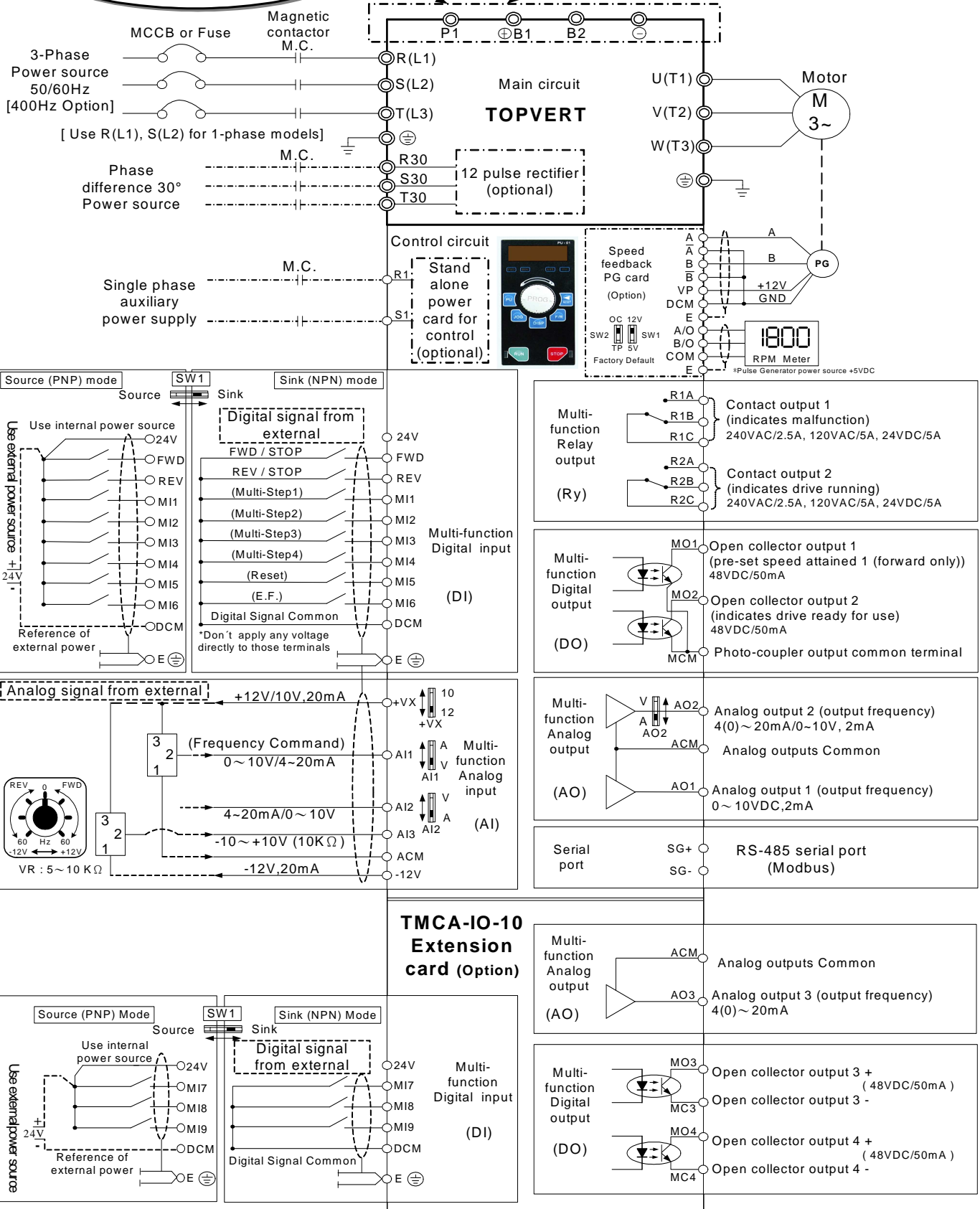
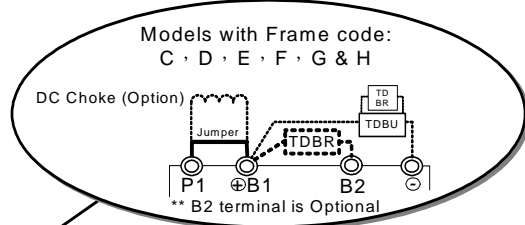
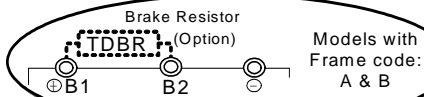

⊙ → Main circuit ⊖ → Control circuit ⊕ → Shielded & twisted leads & Cable () → Factory default [] → option

Main circuit terminal explanations

Terminal Symbol	Content Explanation
R(L1),S(L2),T(L3)	AC source input terminals, to be connected to commercial power. Ensuring the power voltage and the maximum current possible supplied is meet the driver nameplate.
R30,S30,T30 (option)	The phase difference 30° AC source input terminals (When using 12-pulse input, a transformer with a Dual Star-delta Secondary is necessary.) Ensuring the power voltage and the maximum current possible supplied is meet the driver nameplate.
R1,S1 (option)	Extra 1-phase AC source input terminals for main control card, to be connected to commercial power. The voltage rating is same as R(L1),S(L2),T(L3).These terminals can be powered both independent and simultaneously with the main inputs. When These terminals powered only, the drive cannot run, it can precede check signals and management parameter setting and troubleshooting only.
U(T1),V(T2),W(T3)	Drive output terminals for motor connections
⊕/B1, B2	Connections for Brake Resistor (optional) . Refer to Chapter 9
⊕/B1, ⊖	Connecting terminals of the external Dynamic Brake Unit. (DC Bus, power source terminals)
P1, ⊕/B1	Connections for DC choke (option) . Disconnect the short-circuit piece when the device is installed
	Ground terminals, please have these terminals grounded following the third-type grounding of 230V models and the special grounding of 460/575V models within the electrician regulations. There are two ground terminals, one for AC source grounding on the input side. The other one is for motor grounding on the output side.

Control Terminal Explanations

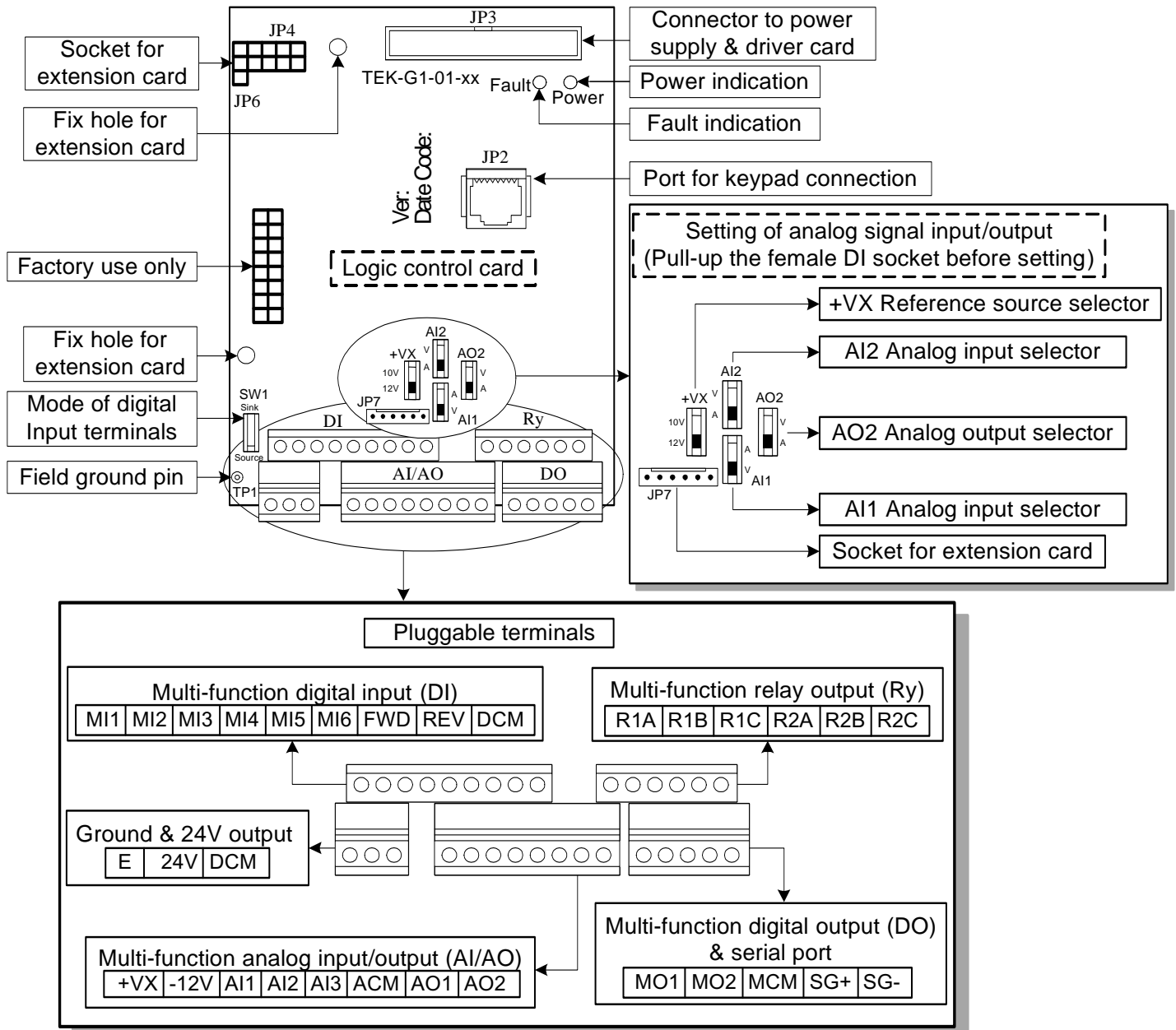

Symbol	Explanation	Ratings/Relative parameters/Factory Default
Digital inputs (Use the shielded twisted-pair cables to prevent operating faults)		
MI1	Multi-function digital input MI1 (3-wire STOP-designated terminal)	Pr2-01/ (multi-step speed command 1)
MI2	Multi-function digital input MI2	Pr2-02/ (multi-step speed command 2)
MI3	Multi-function digital input MI3	Pr2-03/ (multi-step speed command 3)
MI4	Multi-function digital input MI4	Pr2-04/ (multi-step speed command 4)
MI5	Multi-function digital input MI5	Pr2-05/(Abnormal reset command)
MI6	Multi-function digital input MI6 (TRG-designated terminal)	Pr2-06/ (EF input)

FWD	FWD RUN/STOP command	Pr2-00/(FWD RUN/STOP)
REV	REV RUN/STOP command	Pr2-00/(REV RUN/STOP)
DCM	The reference point of digital signal inputs. The reference of +24V control power supply. These terminals are isolated from ACM terminal	Totally 2 DCM terminals with same function.
[MI7]	[Multi-function digital input MI7]	Pr2-26
[MI8]	[Multi-function digital input MI8]	Pr2-27
[MI9]	[Multi-function digital input MI9]	Pr2-28
Relay contact outputs		
Separate these control circuit wiring from wiring for other control terminals		
R1A	Multi-Function digital output 1 Relay 1 (Relay dry contact output)	Pr2-20,Pr2-21 Resistive Load 5A(N.O.)/3A(N.C.) 240VAC 5A(N.O.)/3A(N.C.) 24VDC Inductive Load 1.5A(N.O.)/0.5A(N.C.) 240VAC 1.5A(N.O.)/0.5A(N.C.) 24VDC
R1B	R1A-R1C :Relay 1 Normal open (a contact)	
R1C	R1B-R1C :Relay 1 Normal close (b contact)	
R2A	Multi-Function digital output 2 Relay 2 (Relay dry contact output)	
R2B	R2A-R2C :Relay 2 Normal open (a contact)	
R2C	R2B-R2C :Relay 2 Normal close (b contact)	
Voltage source for digital signal and Frame Ground (Use the shielded twisted-pair cables to prevent operating faults)		
E	Connect to the shield net of shielded twisted-pair cables (Frame Ground)	
24V	Digital control voltage source. Reference point is DCM	Max. 50mA
DCM	The reference point of digital signal inputs. The reference of +24V control power supply. These terminals are isolated from ACM terminal	Totally 2 DCM terminals with same function.
Analog Inputs and outputs (Use the shielded twisted-pair cables to prevent operating faults)		
+VX	+12V/+10V selectable reference voltage source. Reference point is ACM.	Max.20mA/(+12V)
-12V	-12V reference voltage source. Reference point is ACM	Max. 20mA
AI1	Multi-Function analog input 1 (voltage command or current command selectable) (when AI1 analog input selector switch to "V" can accept DC 0~10V voltage signal. when switch to "I" can accept DC 4(0)~20mA current signal.	Pr3-02/ (DC 0~10V corresponding to the maximum operation frequency)
AI2	Multi-Function analog input 2 (current command or voltage command selectable) (when AI2 analog input selector switch to "V" can accept DC 0~10V voltage signal. when switch to "I" can accept DC 4(0)~20mA current signal.	Pr3-06/(4~20mA)
AI3	Multi-Function analog input 3 (accept DC -10~+10 0~10V voltage signal.)	Pr3-11
ACM	The reference point of analog inputs and outputs signal. The reference of reference voltage source. These terminals are isolated from DCM terminals	

AO1	Multi-Function analog output 1 (can output DC 0~10V voltage signal)	Max.2mA/Pr3-15/ (Output frequency)
AO2	Multi-Function analog output 2 (current signal or voltage signal selectable) (when AO2 analog output selector switch to "V" can output DC 0~10V voltage signal. when switch to "I" can output DC 4(0)~20mA current signal.	Pr3-16/(4~20mA) (Output frequency)
[AO3]	[Multi-Function analog output 3] (can output DC 4(0)~20mA current signal)	Pr3-15/(4~20mA) (Output frequency)
Digital outputs and serial port (Use the shielded twisted-pair cables to prevent operating faults)		
MO1	Multi-Function Digital output 3 - MO1	Max.48VDC,50mA/(Pre-set speed attained 1 (Forward only))
MO2	Multi-Function Digital output 4 – MO2	Max.48VDC,50mA/ (Drive ready for use)
MCM	Multi-function output terminal – the common end	
SG+	RS-485 serial port +	
SG-	RS-485 serial port -	
[MO3]	[Multi-Function Digital output 5 MO3+]	Pr2-24
[MC3]	[Multi-Function Digital output 5 MO3-]	
[MO4]	[Multi-Function Digital output 6 MO4+]	Pr2-25
[MC4]	[Multi-Function Digital output 6 MO4-]	

[]:Option

Description of the Digital Keypad

Digital Keypad PU-01 function descriptions

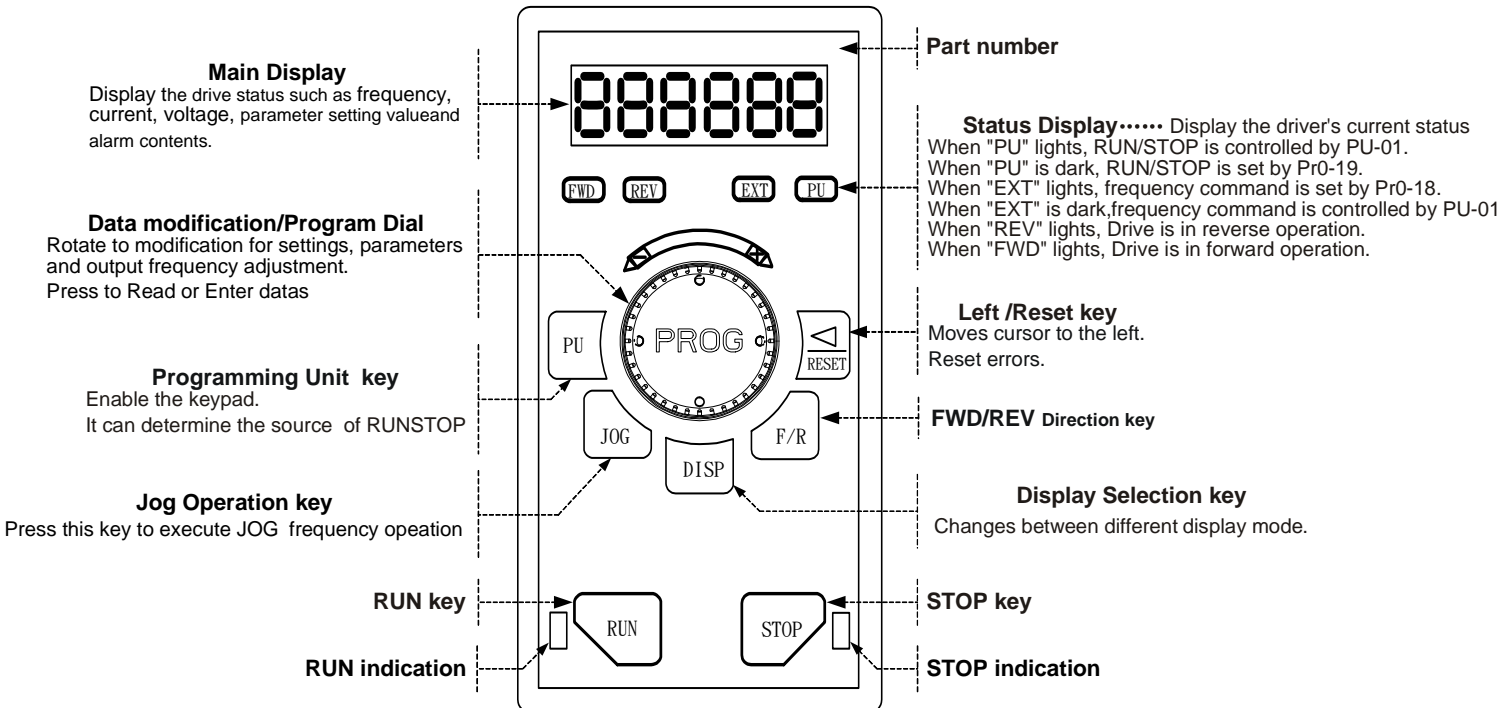

Digital Keypad PU-02 function descriptions

It kept all function in PU-01 and add on Parameter Read/Write/Storage/Copy function. (Valid for Firmware version 2.xx and after only)

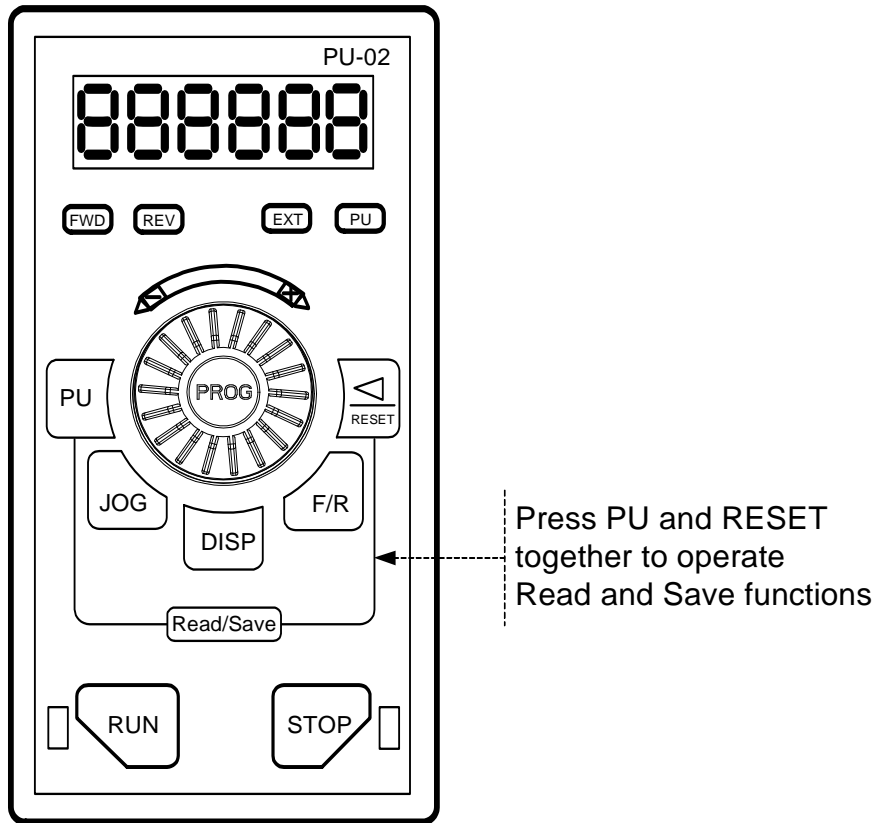





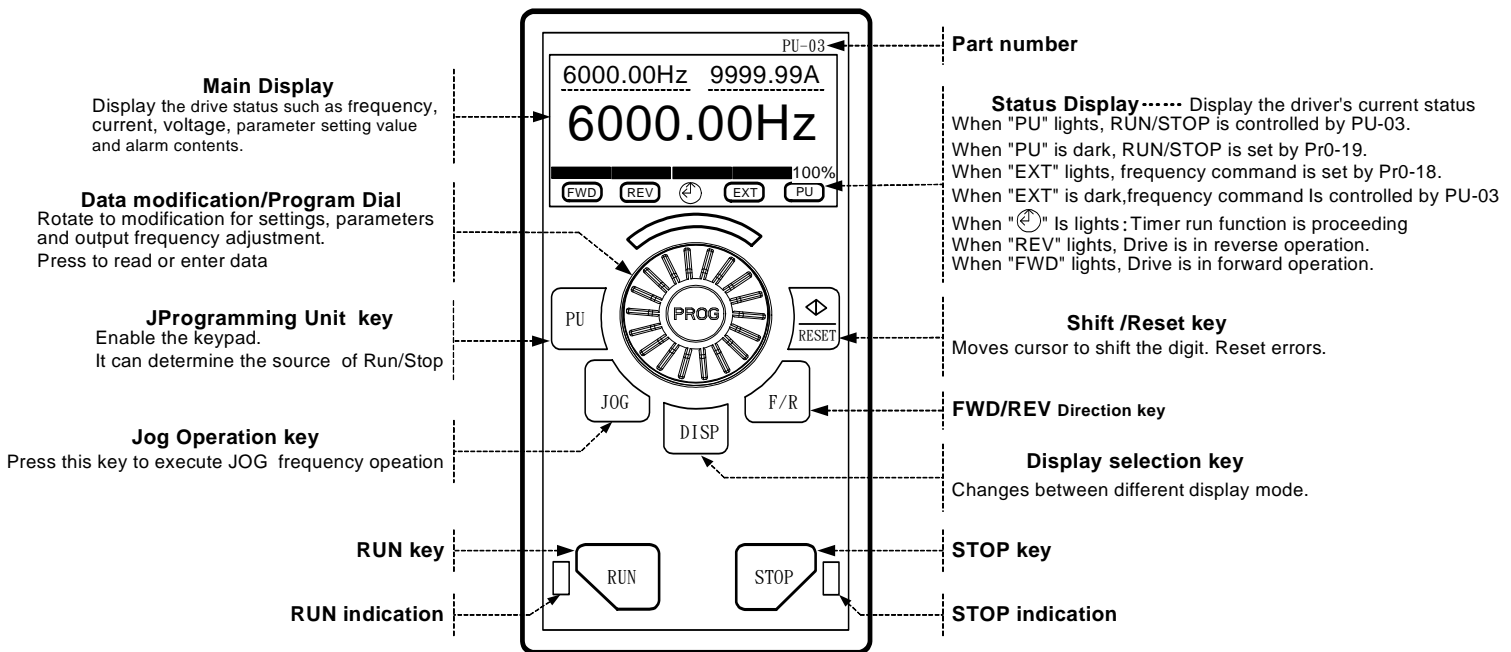





Digital Keypad PU-03 function descriptions

It is an user programmable LCD graphical and text display.



Explanations of Display Messages

Messages Displayed	Descriptions
	Display master frequency command of the drive (Press the DISP key to read)
	Display actual operation frequency output to the motor from the drive (Press the DISP key to read)
	Display output current to motor (Press the DISP key to read)
	Display User-selected content on Pr0-07 (Press the DISP key to read)
	Display Read/Save selected content (For PU-02 only) (Press the DISP key to read)
	The specified parameter item (Rotate and press the  dial to modification, read and Enter) (Press  to display those parameters which data are different from factory default)
	Value of the parameter content (Rotate the  dial to modify for setting parameters)
	If the "End" message is displayed , for about 1 second, it is an indication that the data has been accepted and saved to the internal memory.

Operation Steps Selecting display mode

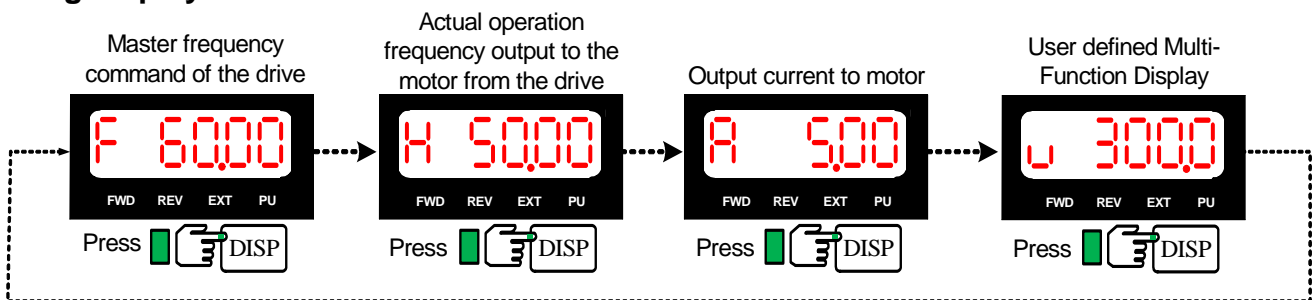

To scrolling between F page, H page, A page and U page by pressing the DISP key

Setting parameters (For example, to set Pr0-07 = 2)

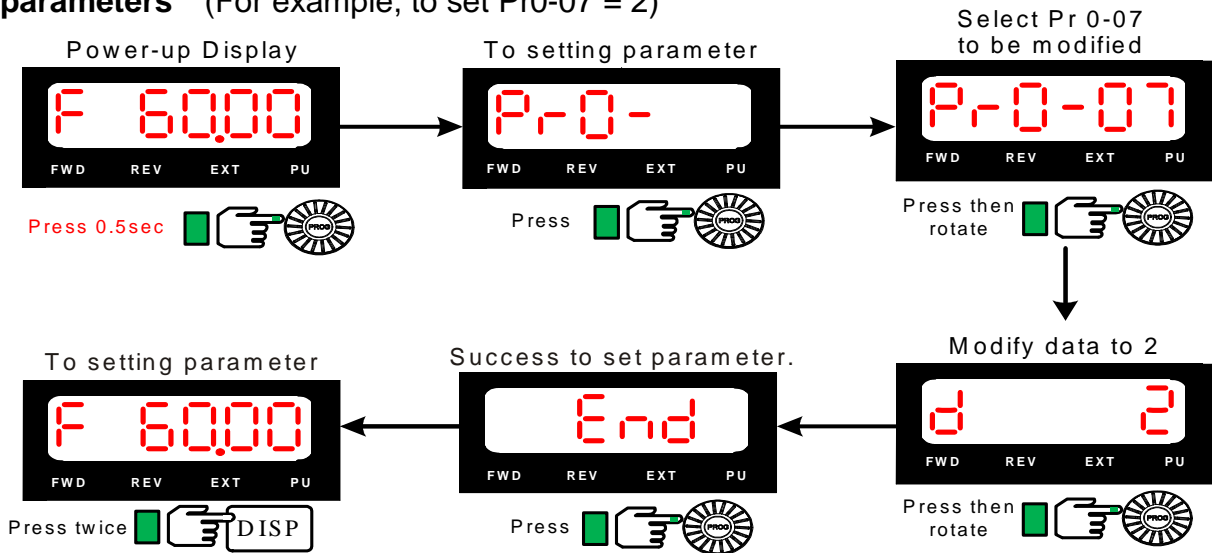

To run (For example, to run 50 Hz from PU)

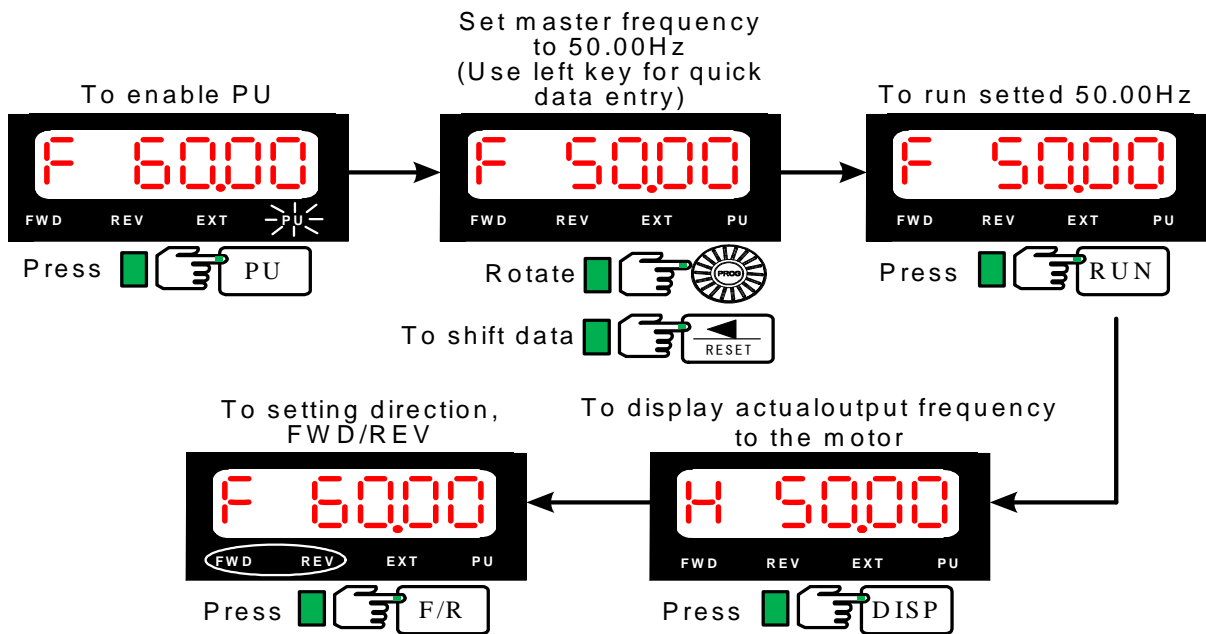

Parameters READ/SAVE Operation (For PU-02 only)
 (Parameter copy can execute between same drive model only)

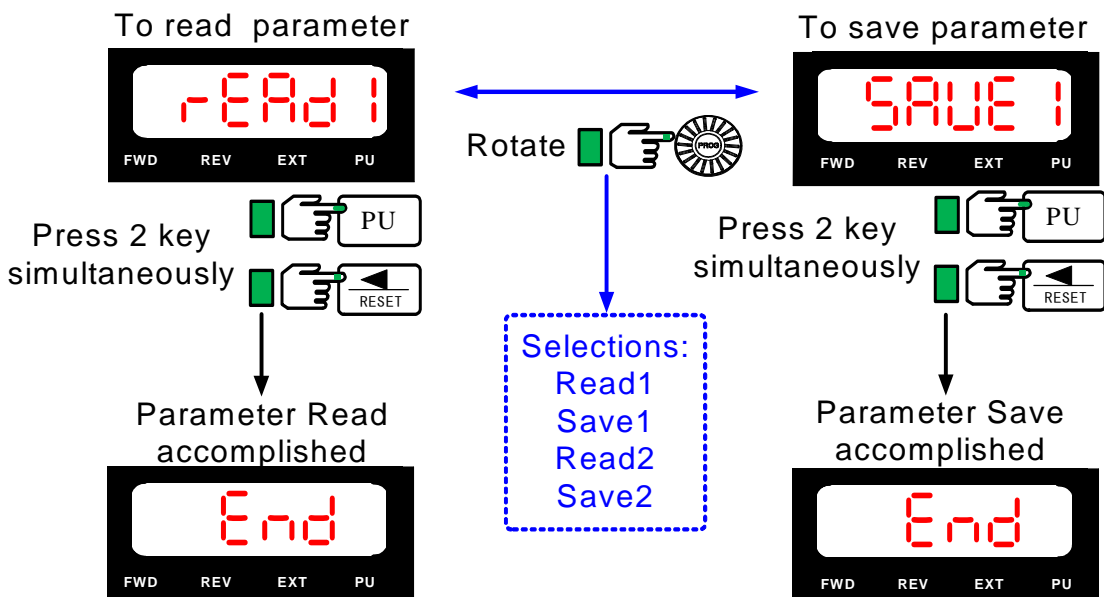

FUNCTIONS AND PARAMETER SUMMARY

★=This parameter cannot be set during operation. { }Parameter no. in Firmware Version 1.xx	◎: Available in Firmware Version 2.xx and after only. []:optional	⊙: Available in Firmware Version 3.xx and after only.
---	---	---

Group 0: System parameters

Parameters	Functions	Settings	Factory Setting	User	
★ Pr0-00	Model display	Display according to the model number	Read Only		
★ Pr0-01	Rated output current to motor	Display according to the model number	Read Only		
★ Pr0-02	Parameter Reset (Motor V/F selecting)	10: Parameter reset for 60Hz - 230/460/575V motor application	8		
		9: Parameter reset for 50Hz - 220/380/575V motor application			
		8: Parameter reset for 60Hz - 220/380/575V motor application			
		7: Parameter reset for 50Hz - 230/460/575V motor application			
		6: Parameter reset for 60Hz - 240/415/575V motor application			
		5: Parameter reset for 50Hz - 240/415/575V motor application			
Pr0-03	Password Input (The Key)	0~9999	0		
Pr0-04	Password set (The Lock)	0~9999	0		
Pr0-05	Parameter Locking Level	Bit0 (bxxx0)	0	b00000	
			1		
		Bit1 (bxxx0x)	0		
			1		
		Bit2 (bxxx0x)	0		
			1		
Pr0-06	Power on display selection	0: Frequency command value	0		
		1: Actual output frequency (Hz)			
		2: Output current			
		3: User defined contents on Pr0-07			
Pr0-07	Versatile display	0: Motor speed (RPM)	0		
		1: DC-Bus Voltage (Vdc)			
		2: Actual output voltage (Vac)			
		3: Output voltage command value (Vac)			
		4: PID feedback frequency value (Hz)			
		5: Running step no. of MSS run			
		6: Sleep time (Pr8-07)			
		7: Auto-Restart after Fault (Pr6-10)			
		8: PID frequency command value (Hz)			
		9: (Factory Reserved)			
		10: Output power factor angle (°)			
		11: Counter value			
		12: Over-Torque detection time 1 (Pr5-17)			
		13: (Factory Reserved)			
		14: Dwell Time at Accel. (Pr6-14)			
		15: Dwell Time at Decel. (Pr6-16)			
		16: DC Braking time in Start-up (Pr6-01)			
		17: DC Braking Time during stop (Pr6-02)			
		18: Remain time of the executing MSS Run			
		19: (Factory Reserved)			
		20: (Factory Reserved)			

			21: Accumulated power-up Day (day)					
			22: Accumulated power-up time (hh:mm)					
			23: (Factory Reserved)					
			24: (Factory Reserved)					
			25: (Factory Reserved)					
			26: The signal of AI1 analog input (Vdc)					
			27: The signal of AI2 analog input (mAdc)					
			28: The signal of AI3 analog input (Vdc)					
			29: (Factory Reserved)					
			30~33: (Factory Reserved)					
			34: Over-Torque detection level 1 (Pr5-16)					
			35: Motor 1 Auto torque boost (Pr5-01)					
			36~37: (Factory Reserved)					
			38: Stall level while run in constant torque area (Pr5-12)					
			39~52: (Factory Reserved)					
			53: Output power (kW)					
			54: Output capacity (kVA)					
			55 : (Factory Reserved)					
			56: The temperature of IGBT module--TH1 (°C)					
			57: The temperature of environment or fin (TH2) (°C)					
			58: (Factory Reserved)					
			59: (Factory Reserved)					
			60: Drive overload accumulated time (OL)					
			61~63 : (Factory Reserved)					
			64: DC Bus voltage upon a fault (Vdc)					
			65: Output voltage upon a fault (Vac)					
			66: Output frequency upon a fault (Hz)					
			67: IGBT module temperature upon a fault (°C)				◎	
			68: Output current value upon a fault (Aac)					
			69 : Temperature of Fin or environment upon a fault (°C)				◎	
70~86 : (Factory Reserved)								
87: DC Bus ripple voltage (Vdc)		◎						
88: PG frequency (Hz)		◎						
	Pr0-08	User-Defined coefficient K	0~39 (no use) 40~60000 (the corresponding value for Pr1-00-- the max. frequency).		0			
	Pr0-09	The decimal places	0~3 (0=Without d.p., 1= 1 digit d.p., 2=2 digit d.p., 3=3 digit d.p.)		0			
	Pr0-10	Firmware version	Read-only		x.xx			
		Pr0-11	EPROM store set	Bit0 (bxxxx0)	0	FWD/REV direction command will be store	b00000	
					1	FWD/REV direction command not store		
				Bit1 (bxxx0x)	0	Frequency command from PU will be store		
					1	Frequency command from PU not store		
				Bit2 (bxx0xx)	0	RS-485 frequency command will be store		
					1	RS-485 frequency command not store		
				Bit3 (bx0xxx)	0	Up/Down frequency command will be store		
					1	Up/Down frequency command not store		
				Bit4 (b0xxxx)	0	Changed parameter will be store		
					1	Changed parameter not store		

	Pr0-12	Auto Accelerate/ Decelerate	0: Linear Acc, linear Dec. 1: Auto Acc, linear Dec. 2: Linear Acc, auto Dec. 3: Auto Acc, auto Dec. 4: Linear Acc./Dec., auto to prevent stall.		0		
★	Pr0-13	Accelerate/ Decelerate time unit	0: 0.01 Second 1: 0.1 Second 2: 1 Second		0		
	Pr0-14	PWM Carrier frequency upper bound	0=0.7kHz 1~18kHz		10		
	Pr0-15	PWM Carrier frequency lower bound	0=0.7kHz 1~18kHz		10		
	Pr0-16	Automatic Voltage Regulation (AVR)	0: Enable Automatic Voltage Regulation 1: Disable Automatic Voltage Regulation 2: Disable Automatic Voltage Regulation while in decele		0		
	Pr0-17	Automatic Energy-Saving Operation (AESO) and others	Bit0 (bxxxx0)	0 1 0 1 0 1 0 1 0 1	Disable Automatic Energy-Saving Operate Enable Automatic Energy-Saving Operate Allow output voltage over source voltage Maximum output voltage equals to source voltage For constant torque load application. For variable torque load application. Regen-torque no slip compensation Regen-torque with slip compensation Low noise mode operation Quiet mode operation	b00000	
	Pr0-18	Source of the frequency command	0: From PU 1: From RS485 communication port 2: From external analog signal 3: From external Up/Down terminals 4: From Pulse input via PG Feedback Card		0	◎	
	Pr0-19	Source of the operation command	0: From RS485 communication port or PU 1: From external terminals or PU 2: From PU 3: From external terminals		0		
	Pr0-20	Stop/ Run/safety lockout	Bit0 (bxxxx0)	0 1 0 1 0 1 0 1	Ramp to stop Coast to stop Terminal command not run after reset Terminal command restart after reset Line start Lockout is enabled Line start Lockout is disabled FWD/REV go through zero point FWD/REV go not through zero point Linear Accel/Decel at high speed zone S-curve Accel/Decel at high speed zone	b00000	
	Pr0-21	Direction limit	0: Enable Forward/Reverse operation 1: Disable Reverse operation 2: Disabled Forward operation		0		
	Pr0-22	Waiting time to restart after stop	0.00~60.00sec		0.00		

	Pr0-23	Cooling fan control & PID direction	Bit0 (bxxxx0)	0	Fan on while power on	b00000	
				1	Fan on while run command effect		
			Bit1 (bxxx0x)	0	(Factory Reserved)		
				1			
			Bit2 (bxx0xx)	0	(Factory Reserved)		
				1			
Bit3 (bx0xxx)	0	PID reverse operation allow					
	1	PID reverse operation not allow					
★ ◎	Pr0-25	Parameter select	Bit4 (b0xxxx)	0	(Factory Reserved)	0	
				1			
	Pr0-24	Resolution of dial	0=0.01 Hz		1		
			1=0.10Hz				
			2=1.00Hz				
			3=10.00 Hz				
★ ◎	Pr0-25	Parameter select	0: Team A		0		
			1: Team B				
			2: Select Team A or Team B by MI3				

Group 1: Basic parameters

	Parameters	Functions	Settings	Factory Setting	User
★	Pr1-00	Maximum operation frequency	3.00~600.00Hz (H1:100.0 ~6000.0Hz)	60.00/ 50.00	
★	Pr1-01	1st Frequency 1 (Base frequency 1) (Fbase 1)	0.00~600.00 Hz (H1:00.0 ~6000.0Hz)	60.00/ 50.00	
	Pr1-02	1st Voltage 1 (Motor rated voltage 1) (Vbase 1)	230V models: 0.0~255.0V	230.0	
			460V models: 0.0~510.0V	460.0	
			◎ 575V models: 0.0~637.5V	575.0	
★	Pr1-03	2nd Frequency 1 (Middle frequency 1) (Fmid 1)	0.00~600.00 Hz (H1:00.0 ~6000.0Hz)	0.50	
	Pr1-04	2nd Voltage 1 (Middle voltage 1) (Vmid 1)	230V models: 0.0~255.0V	5.0	
			460V models: 0.0~510.0V	10.0	
			◎ 575V models:0.0~637.5V	12.5	
★	Pr1-05	3rd Frequency 1 (Low-point frequency 1) (Flow 1)	0.00~600.00 Hz (H1:00.0 ~6000.0Hz)	0.50	
	Pr1-06	3rd Voltage 1 (Low-point voltage 1) (Vlow 1)	230V models: 0.0~255.0	5.0	
			460V models: 0.0~510.0V	10.0	
			◎ 575V models: 0.0~637.5V	12.5	
	Pr1-07	0Hz Voltage 1 (Output voltage at 0Hz) (V0Hz 1)	230V models: 0.0~25.5	0.0	
			460V models: 0.0~51.0V		
			◎ 575V models: 0.0~63.7V		
	Pr1-08	Start-up frequency	0.00~600.00 Hz (H1:00.0 ~6000.0Hz)	0.50	
	Pr1-09	Output frequency Upper limit	0.0~150.0% of Maximum operation frequency (Pr1-00)	110.0	
	Pr1-10	Output Frequency Lower limit	0.0~100.0% of Maximum operation frequency (Pr1-00)	0.0	
	Pr1-11	1st Acceleration time	0.00~60000 Sec	##.##	
	Pr1-12	1st Deceleration time	0.00~60000 Sec		
	Pr1-13	2nd Acceleration time	0.00~60000 Sec		
	Pr1-14	2nd Deceleration time	0.00~60000 Sec		
	Pr1-15	JOG Acceleration time	0.00~60000 Sec		
	Pr1-16	JOG Deceleration time	0.00~60000 Sec		
	Pr1-17	JOG frequency	0.00~600.00 Hz (H1:00.0 ~6000.0Hz)	6.00	
	Pr1-18	1st/2nd Acceleration/Deceleration Switching frequency	0.00~600.00 Hz (H1:00.0 ~6000.0Hz)	0.000	

	Pr1-19	S-Acc. departure time when accelerate	0.00~12000 Sec	0.00	
	Pr1-20	S-Acc. arrival time when accelerate	0.00~12000 Sec	0.00	
	Pr1-21	S-Dec. departure time when decelerate	0.00~12000 Sec	0.00	
	Pr1-22	S-Dec. arrival time when decelerate	0.00~12000 Sec	0.00	
	Pr1-23 {Pr1-29}	Offset voltage while decelerate	230V models: -50.0~50.0 V	0.00	
460V models: -100.0~100.0 V					
◎575V models: -125.0~125.0 V					
★	Pr1-24 {Pr1-23}	Skip Frequency 1 upper limit	0.00~600.00Hz (H1:00.0~6000.0Hz)	0.00	
★	Pr1-25 {Pr1-24}	Skip Frequency 1 lower limit	0.00~600.00Hz (H1:00.0~6000.0Hz)	0.00	
★	Pr1-26 {Pr1-25}	Skip Frequency 2 upper limit	0.00~600.00Hz (H1:00.0~6000.0Hz)	0.00	
★	Pr1-27 {Pr1-26}	Skip Frequency 2 lower limit	0.00~600.00Hz (H1:00.0~6000.0Hz)	0.00	
★	Pr1-28 {Pr1-27}	Skip Frequency 3 upper limit	0.00~600.00Hz (H1:00.0~6000.0Hz)	0.00	
★	Pr1-29 {Pr1-28}	Skip Frequency 3 lower limit	0.00~600.00Hz (H1:00.0~6000.0Hz)	0.00	
★ ◎	Pr1-30	Skip Frequency 4 upper limit	0.00~600.00 Hz (H1:00.0 ~6000.0Hz)	0.00	
★ ◎	Pr1-31	Skip Frequency 4 lower limit	0.00~600.00 Hz (H1:00.0 ~6000.0Hz)	0.00	
★ ◎	Pr1-32	Skip Frequency 5 upper limit	0.00~600.00 Hz (H1:00.0 ~6000.0Hz)	0.00	
★ ◎	Pr1-33	Skip Frequency 5 lower limit	0.00~600.00 Hz (H1:00.0 ~6000.0Hz)	0.00	
★ ◎	Pr1-34	Skip Frequency 6 upper limit	0.00~600.00 Hz (H1:00.0 ~6000.0Hz)	0.00	
★ ◎	Pr1-35	Skip Frequency 6 lower limit	0.00~600.00 Hz (H1:00.0 ~6000.0Hz)	0.00	
★ ◎	Pr1-36	1st Frequency 2 (Base frequency 2) (Fbase 2)	0.00~600.00 Hz (H1:00.0 ~6000.0Hz)	60.00/ 50.00	
◎	Pr1-37	1st Voltage 2 (Motor rated voltage 2) (Vbase 2)	230V models: 0.0~255.0V	230	
			460V models: 0.0~510.0V	460	
			◎575V models:0.0~637.5V	575	
★ ◎	Pr1-38	2nd Frequency 2 (Middle frequency 2) (Fmid 2)	0.00~600.00 Hz (H1:00.0 ~6000.0Hz)	0.50	
★ ◎	Pr1-39	2nd Voltage 2 (Middle voltage 2) (Vmid 2)	230V models: 0.0~255.0V	5.0	
			460V models: 0.0~510.0V	10.0	
			◎ 575V models:0.0~637.5V	12.5	
★ ◎	Pr1-40	3rd Frequency 2 (Low-point frequency 2) (Flow 2)	0.00~600.00 Hz (H1:00.0 ~6000.0Hz)	0.50	
★ ◎	Pr1-41	3rd Voltage 2 (Low-point voltage 2) (Vlow 2)	230V model: 0.0~255.0V	5.0	
			460V model: 0.0~510.0V	10.0	
			◎575V models: 0.0~637.5V	12.5	
★ ◎	Pr1-42	0Hz Voltage 2 (Output voltage at 0Hz) (V0Hz 2)	230V models: 0.0~25.5	0.0	
			460V models: 0.0~51.0V		
			◎ 575V models: 0.0~63.7V		

Group 2: Digital Input/Output parameters

	Parameters	Functions	Settings	Factory Setting	User																		
★	Pr2-00	External operation	0: 2-wire mode 1- FWD/STOP, REV/STOP 1: 2-wire mode 2- RUN/STOP, REV/FWD 2: 3-wire mode -RUN,STOP, FWD/REV	0																			
★	Pr2-01	Multi-Function Digital input MI1	0: No definition	1																			
★	Pr2-02	Multi-Function Digital input MI2	1: Multi-step speed command 1	2																			
★	Pr2-03	Multi-Function Digital input MI3	2: Multi-step speed command 2	3																			
★	Pr2-04	Multi-Function Digital input MI4	3: Multi-step speed command 3	4																			
★	Pr2-05	Multi-Function Digital input MI5	4: Multi-step speed command 4	5																			
★	Pr2-06 [Pr2-26] [Pr2-27] [Pr2-28]	Multi-Function Digital input MI6	5: External Reset	14																			
			6: Clear counter																				
			7: 1st and 2nd acceleration/ deceleration time select																				
			8: Acceleration/deceleration inhibit																				
			9: Force the frequency command from AI1																				
			10: Force the frequency command from AI2																				
			11: Force the frequency command from AI3																				
			12: Emergency stop																				
			13: Disable PID function																				
			14: External fault input (EF)																				
			15: B.B. traces from the bottom upward																				
			16: B.B. traces from the top downward																				
			17: Force operation command to external																				
			18: Cancel the auto acceleration/ deceleration function																				
			19: FWD JOG command																				
			20: REV JOG command																				
			21: JOG command																				
			22: Cancel PLC Run																				
			23: Pause PLC Run																				
			24: Up command																				
			25: Down command																				
			26: Zero speed is replaced by DC braking																				
			27: Pause																				
			28: Disable dwell function																				
			29: Disable traverse function																				
			30: Disable Speed search during start-up																				
			31: Disable EEPROM write function																				
32: Counter Trigger input (MI2 only)																							
33~41: (Factory Reserved)																							
42: Motor Select	⊙																						
43: Confirm signal of Motor selection	⊙																						
44: Disable reverse operation	⊙																						
45: Disabled forward operation	⊙																						
	Pr2-07	Up/Down command mode	<table border="1"> <tr> <td rowspan="2">Bit 0 (bxxxx0)</td> <td>0</td> <td>Up command-Accel by the Acc. time</td> </tr> <tr> <td>1</td> <td>Up command-Accel by Pr2-08 setting</td> </tr> <tr> <td rowspan="2">Bit 1 (bxxx0x)</td> <td>0</td> <td>Down Command-Decel by the Dec. time</td> </tr> <tr> <td>1</td> <td>Down Command-Decel by Pr2-08 setting</td> </tr> <tr> <td>Bit 2 (bxx0xx)</td> <td></td> <td>(Factory Reserved)</td> </tr> <tr> <td rowspan="2">Bit 3 (bx0xxx)</td> <td>0</td> <td>FWD/REV terminals act by edge trigger</td> </tr> <tr> <td>1</td> <td>FWD/REV terminals act by level trigger</td> </tr> </table>	Bit 0 (bxxxx0)	0	Up command-Accel by the Acc. time	1	Up command-Accel by Pr2-08 setting	Bit 1 (bxxx0x)	0	Down Command-Decel by the Dec. time	1	Down Command-Decel by Pr2-08 setting	Bit 2 (bxx0xx)		(Factory Reserved)	Bit 3 (bx0xxx)	0	FWD/REV terminals act by edge trigger	1	FWD/REV terminals act by level trigger	b00000	
Bit 0 (bxxxx0)	0	Up command-Accel by the Acc. time																					
	1	Up command-Accel by Pr2-08 setting																					
Bit 1 (bxxx0x)	0	Down Command-Decel by the Dec. time																					
	1	Down Command-Decel by Pr2-08 setting																					
Bit 2 (bxx0xx)		(Factory Reserved)																					
Bit 3 (bx0xxx)	0	FWD/REV terminals act by edge trigger																					
	1	FWD/REV terminals act by level trigger																					

			Bit 4 (b0xxxx)	0	Allow PG feed-back over compensation while Accel.		
				1	Refuse PG feed-back over compensation while Accel.		
	Pr2-08	Up/Down command rate	0.01 ~ 1.00Hz/msec (10 ~ 1000Hz/sec)			0.01	
	Pr2-09	Digital Input terminal debounce time	0.001 ~ 30.000 Sec			0.005	
	Pr2-10	Polarity of Digital Input terminals	00000~007FF		h00000		
			(0=Close circuit enable 1=Open circuit enable)				
	Pr2-11	Target count value	0 ~ 65500			0	
	Pr2-12	Pre warn count value	0 ~ 65500			0	
	Pr2-13	Digital pulse output gain	1~20			1	
	Pr2-14	Pre-set arrival frequency 1	0.00 ~ 600.00 Hz (H1:00.0 ~ 6000.0Hz)			60.00/ 50.00	
	Pr2-15	Pre-set arrival frequency 1 bandwidth	0.00 ~ 600.00 Hz (H1:00.0 ~ 6000.0Hz)			2.00	
	Pr2-16	Pre-set arrival frequency 2	0.00 ~ 600.00 Hz (H1:00.0 ~ 6000.0Hz)			60.00/ 50.00	
	Pr2-17	Pre-set arrival frequency 2 bandwidth	0.00 ~ 600.00 Hz (H1:00.0 ~ 6000.0Hz)			2.00	
	Pr2-18	Polarity of Digital output terminals	00000~0003F			h00000	
◎	Pr2-19	Delay time of Digital output terminals	0.000~60.000 Sec			0.003	
	Pr2-20 {Pr2-19}	Multi-Function Digital output 1 - Relay 1	0: No definition			11	
	Pr2-21 {Pr2-20}	Multi-Function Digital output 2 - Relay 2	1: Drive in run			1	
	Pr2-22 {Pr2-21}	Multi-Function Digital output 3 - MO1	2: Master frequency attained 1 (Both Forward and Reverse)			5	
	Pr2-23 {Pr2-22}	Multi-Function Digital output 4 - MO2	3: Master frequency attained 2 (Both Forward and Reverse)			9	
◎	Pr2-24	[Multi-Function Digital output 5 - MO3]	4: Pre-set speed attained 1 (Both Forward and Reverse)			0	
◎	Pr2-25	[Multi-Function Digital output 6 - MO4]	5: Pre-set speed attained 1 (Forward only)			0	
			6: Pre-set speed attained 2 (Both Forward and Reverse)			0	
			7 : Pre-set speed attained 2 (Forward only)				
			8: Drive in decel				
			9: Drive ready for operate				
			10: Low voltage alarm (LU, LUr)				
			11: Fault Indication				
			12: Base block (B.B.) Indication				
			13: Zero Speed (including shutdown)				
			14: Zero speed (while in run)				
			15: Terminal count value attained				
			16: Pre warn count value attained				
			17: PLC Run running				
			18: PLC Run paused				
			19: A step of PLC Run completed				
			20: PLC Run completed				
			21: OH1 pre-warning indication				
			22: Dwell Accel/Decel in execution				
			23: External operation mode indication				
			24: Over-torque 1 (ot1)				
25: Digital frequency output (MO2 only)							
26: Software brake output (MO1 only)							
27: Auxiliary Motor no. 1							
28: Auxiliary Motor no. 2							
29: Auxiliary Motor no. 3							

			30: Over-torque 2 (ot2)	⊙	
			31: OH2 pre-warning indication	⊙	
			32: Motor selection output (Pr5-49)	⊙	
			33~47: (Factory Reserved)		
			48: Master speed executing		
			49: PLC Run step 1 executing		
			50: PLC Run step 2 executing		
			51: PLC Run step 3 executing		
			52: PLC Run step 4 executing		
			53: PLC Run step 5 executing		
			54: PLC Run step 6 executing		
			55: PLC Run step 7 executing		
			56: PLC Run step 8 executing		
			57: PLC Run step 9 executing		
			58: PLC Run step 10 executing		
			59: PLC Run step 11 executing		
			60: PLC Run step 12 executing		
			61: PLC Run step 13 executing		
			62: PLC Run step 14 executing		
			63: PLC Run step 15 executing		
			64~79: (Factory Reserved)		
⊙	Pr2-26	[Multi-Function Digital input MI7]	Same as Pr2-01~Pr2-06	0	
⊙	Pr2-27	[Multi-Function Digital input MI8]			
⊙	Pr2-28	[Multi-Function Digital input MI9]			

Group 3: Analog Input/Output parameters

Parameters	Functions	Settings	Factory Setting	User
Pr3-00	Addition Function of the Analog Inputs	0: Enable addition function 1: Disable addition function	0	
Pr3-01	Analog input noise filter time	0.00~2.00 sec	0.10	
Pr3-02	AI1 Analog Input	0: No functions 1: Frequency command 2: To adjust 1st Acceleration/deceleration time (same as Pr1-11, Pr1-12) 3: Over Current stall prevention level during constant speed run on the constant torque region (same as Pr5-12) 4: Over Current stall prevention level during accel on the constant torque region (same as Pr5-10) 5: Over-Torque detection level 1 (ot1) (same as Pr5-16) 6: Motor 1 Torque boost level (same as Pr5-01) 7: Auxiliary command when main frequency command is AI1 only 8: Auxiliary command when main frequency command is AI2 only 9: Auxiliary command when main frequency command is AI3 only 10: Auxiliary command of master frequency command 11: PID feedback signal 12: PID offset signal (same as Pr7-05) 13: DC Braking current level (same as Pr6-00) 14: Voltage adjusts during run. (AI1 Pr3-02 only) 15: External temperatures signal	1	
Pr3-03	AI1 analog Input bias	-10.00~10.00V	0.00	
Pr3-04	AI1 analog Input gain	-500.0~+500.0%	100.0	

Pr3-05	AI1 analog Input bias mode	0: Zero bias	0	
		1: Value lower than bias = bias		
		2: Value higher than bias = bias		
		3: The absolute value of the bias voltage while serving as the center		
Pr3-06	AI2 Analog Input (see Pr3-02)	Same as Pr3-02	0.00	
Pr3-07	AI2 analog Input bias	0.00~20.00mA	4.00	
Pr3-08	AI2 analog Input gain	-500.0~+500.0%	100.0	
Pr3-09	AI2 analog Input bias mode	0 : Zero bias	1	
		1: Value lower than bias = bias		
		2: Value higher than bias = bias		
		3: The absolute value of the bias voltage while serving as the center		
Pr3-10	Loss of the AI2 signal	0: Disabled	0	
		1: Continue operation by the last frequency command		
		2: Decelerate to stop		
		3: Coast to stop and display Acl.		
Pr3-11	AI3 Analog Input (see Pr3-02)	(Same as Pr3-02)	0.00	
Pr3-12	AI3 analog Input bias	-10.00~10.00V	0.00	
Pr3-13	AI3 analog Input gain	-500.0~+500.0%	100	
Pr3-14	AI3 analog Input bias mode	0: Zero bias	0	
		1: Value lower than bias = bias		
		2: Value higher than bias = bias		
		3: The absolute value of the bias voltage while serving as the center		
Pr3-15	Analog output 1 function (AO1)	0: Output frequency (Hz)	0	
Pr3-16	Analog output 2 function (AO2)	1: Command frequency (Hz)	0	
		2: Motor Speed		
		3: Output current (A rms)		
		4: Output voltage (VAC)		
		5: DC BUS voltage (VDC)		
		6: Power factor		
		7: Power		
		8: AI1 (V)		
		9: AI2 (mA)		
		10: AI3 (V)		
		11~12: (Factory Resewrved)		
		13: Output voltage command		
		14: Counter Value		
		15: User defined value on Pr3-21		
16~23: (Factory Reserved)				
24: Define to digital output (MOx)	⊙			
Pr3-17	AO1 Analog output gain	-900.0~900.0%	100.0	
Pr3-18	AO2 Analog output gain	-900.0~900.0%	80.0	
Pr3-19	AO1 Analog output bias	-10.00~10.00V	0.00	
Pr3-20	AO2 Analog output bias	0.00~20.00mA	4.00	
Pr3-21	User defined analog output value	0.0~100.0%	0.0	

Group 4: Multi-Step Speed and Process Logic Control operation parameters

Parameters	Functions	Settings	Factory Setting	User
Pr4-00	The 1st step speed of PLC Run or MSS Run	0.00~600.00 Hz (H1:00.0 ~6000.0Hz)	0.00	
Pr4-01	The 2nd step speed of PLC Run or MSS Run	0.00~600.00 Hz (H1:00.0 ~6000.0Hz)	0.00	
Pr4-02	The 3rd step speed of PLC Run or MSS Run	0.00~600.00 Hz (H1:00.0 ~6000.0Hz)	0.00	

Pr4-03	The 4th step speed of PLC Run or MSS Run	0.00~600.00 Hz (H1:00.0 ~6000.0Hz)	0.00		
Pr4-04	The 5th step speed of PLC Run or MSS Run	0.00~600.00 Hz (H1:00.0 ~6000.0Hz)	0.00		
Pr4-05	The 6th step speed of PLC Run or MSS Run	0.00~600.00 Hz (H1:00.0 ~6000.0Hz)	0.00		
Pr4-06	The 7th step speed of PLC Run or MSS Run	0.00~600.00 Hz (H1:00.0 ~6000.0Hz)	0.00		
Pr4-07	The 8th step speed of PLC Run or MSS Run	0.00~600.00 Hz (H1:00.0 ~6000.0Hz)	0.00		
Pr4-08	The 9th step speed of PLC Run or MSS Run	0.00~600.00 Hz (H1:00.0 ~6000.0Hz)	0.00		
Pr4-09	The 10th step speed of PLC Run or MSS Run	0.00~600.00 Hz (H1:00.0 ~6000.0Hz)	0.00		
Pr4-10	The 11th step speed of PLC Run or MSS Run	0.00~600.00 Hz (H1:00.0 ~6000.0Hz)	0.00		
Pr4-11	The 12th step speed of PLC Run or MSS Run	0.00~600.00 Hz (H1:00.0 ~6000.0Hz)	0.00		
Pr4-12	The 13th step speed of PLC Run or MSS Run	0.00~600.00 Hz (H1:00.0 ~6000.0Hz)	0.00		
Pr4-13	The 14th step speed of PLC Run or MSS Run	0.00~600.00 Hz (H1:00.0 ~6000.0Hz)	0.00		
Pr4-14	The 15th step speed of PLC Run or MSS Run	0.00~600.00 Hz (H1:00.0 ~6000.0Hz)	0.00		
Pr4-15	The duration of master speed	0.0~65500 Sec	0.0		
Pr4-16	The 1st step duration of PLC Run or MSS Run	0.0~65500 Sec	0.0		
Pr4-17	The 2nd step duration of PLC Run or MSS Run	0.0~65500 Sec	0.0		
Pr4-18	The 3rd Step duration of PLC Run or MSS Run	0.0~65500 Sec	0.0		
Pr4-19	The 4th Step duration of PLC Run or MSS Run	0.0~65500 Sec	0.0		
Pr4-20	The 5th Step duration of PLC Run or MSS Run	0.0~65500 Sec	0.0		
Pr4-21	The 6th Step duration of PLC Run or MSS Run	0.0~65500 Sec	0.0		
Pr4-22	The 7th Step duration of PLC Run or MSS Run	0.0~65500 Sec	0.0		
Pr4-23	The 8th Step duration of PLC Run or MSS Run	0.0~65500 Sec	0.0		
Pr4-24	The 9th Step duration of PLC Run or MSS Run	0.0~65500 Sec	0.0		
Pr4-25	The 10th Step duration of PLC Run or MSS Run	0.0~65500 Sec	0.0		
Pr4-26	The 11th Step duration of PLC Run or MSS Run	0.0~65500 Sec	0.0		
Pr4-27	The 12th Step duration of PLC Run or MSS Run	0.0~65500 Sec	0.0		
Pr4-28	The 13th Step duration of PLC Run or MSS Run	0.0~65500 Sec	0.0		
Pr4-29	The 14th Step duration of PLC Run or MSS Run	0.0~65500 Sec	0.0		
Pr4-30	The 15th Step duration of PLC Run or MSS Run	0.0~65500 Sec	0.0		
Pr4-31	The PLC Run or MSS Run time multiplier	1~10	1		
Pr4-32	The PLC Run or MSS Run operation direction of each step	00000~07FFF (0 : forward ; 1 : reverse)	h00000		
Pr4-33	PLC Run operation mode	Bit 0 (bxxxx0)	0	Direction determined by Pr4-32	b01000
			1	Direction determined by the master speed	
		Bit 1 (bxxx0x)	0	Without zero intervals (Continue mode)	
			1	With zero intervals (Stop mode)	
		Bit 2 (bxx0xx)	0	Run zero speed when PLC Run Paused	
			1	Run original	

					programmed step speed when PLC Run Paused		
			Bit 3 (bx0xxx)	0	Re-Execute PLC Run from step 0 after recover from power interruption		
				1	Continue Execute PLC Run from the point which power interrupted after recover from power interruption		
	Pr4-34	PLC Run operation cycle	0~60000 : 0~60000 cycle			0	
			0= PLC Run disabled				
			60001: Continuously execute recurring cycles				
	Pr4-35	What to do after PLC Run completed	0~15 : step speed (0=master speed)			16	
			16 : stop				
	Pr4-36	Multi-Step Speed Run (MSS RUN) operation mode	Bit 0 (bxxxx0)	0	Direction determined by Pr4-32	b00001	
				1	Direction determined by the master speed		
			Bit 1 (bxxx0x)	0	Duration of MSS Run determined by Mix terminals.		
				1	Duration of MSS Run determined by Pr4-15~Pr4-30 setting.		
			Bit 2 (bxx0xx)	0	Without zero intervals (Continue mode)		
				1	With zero intervals (Stop mode)		
	Bit 3 (bx0xxx)	0	Jog command ineffective during Run				
		1	Jog command effective during Run				

Group 5: Motor parameters and protection parameters

	Parameters	Functions	Settings	Factory Setting	User
★	Pr5-00	Full-Load Current of Motor 1	Amp (10~120% of drive's rated current)	##.##	
	Pr5-01	Auto Torque Compensation of Motor 1	0.0~25.0%	0.0	
	Pr5-02	Slip Compensation of Motor 1	0~20 RPM	0	
	Pr5-03	Number of Motor Poles 1	2~20	4	
	Pr5-04	Rotor Resistance R1 of Motor 1	0.000~65.535 Ω	0	
★	Pr5-05	Auto-tuning & control mode selection	0: No function	0	
			1: To execute auto-tuning and switch to Sensorless vector control mode		
			2: Reset to V/F control mode		
★	Pr5-06	Low Voltage Level I	230V models: 160~220VAC	180	
			460V models: 320~440VAC	360	
			Ⓢ 575V models: 400~550VAC	450	

★	Pr5-07	Over-Voltage Stall Prevention Level	230V models: 320~500VDC	380	
			460V models: 640~1000VDC	760	
			⊙ 575V models: 800~1250VDC	950	
	Pr5-08	Software Braking Level	230V models: 320~500VDC	373	
			460V models: 640~1000VDC	746	
			⊙ 575V models: 800~1250VDC	932	
	Pr5-09	Phase-Loss Protection	0: Warn and keep operation (below 50%)	0	
			1: Warn and ramp to stop		
			2: Warn and coast to stop		
	Pr5-10	Over- Current Stall Prevention level during accel on the constant torque region	Amp (10~250% of drive's rated current)	##.##	
	Pr5-11	Over- Current Stall Prevention low-limit level during accel on the constant power region	Amp (0~250% of drive's rated current)	##.##	
	Pr5-12	Over-Current Stall Prevention level during constant speed on the constant torque region Operation	Amp (10~250% of drive's rated current)	##.##	
	Pr5-13	Over- Current Stall Prevention low-limit level during constant speed run on the constant power region	Amp (0~250% of drive's rated current)	##.##	
	Pr5-14	Over-Current Deceleration Time during Operation	0.050~600.00 Sec	3.00	
	Pr5-15	Over-Torque Detection Selection 1 (ot1)	0 : Disabled	0	
			1 : Over-torque detection during constant speed operation, stop operation after detection.		
			2 : Over-torque detection during constant speed operation, continue to operate after detection.		
			3 : Over-torque detection during operation, stop operation after detection		
			4 : Over-torque detection during operation, continue operation after detection.		
	Pr5-16	Over-Torque Detection Level 1 (ot1)	Amp(10~250% of drive's rated current)	##.##	
	Pr5-17	Over-Torque Detection Time 1 (ot1)	0.0~60.0 Sec	0.1	
	Pr 5-18	Motor 1- Electronic Thermal Relay Selection (oL1)	0 : Electronic thermal relay function disabled	0	
			1 : Inverter duty motor (with independent cooling fan)		
			2 : Standard motor (with shaft mounted cooling fan)		
	Pr5-19	Motor 1- Electronic Thermal Relay Characteristic	30~600 Sec	60	
	Pr5-20	IGBT Over-Heat pre-warning setting (oH2)	0.0~110.0	85.0	
	Pr5-21	Over-Torque Detection Selection 2 (ot2)	0: Disabled	0	
			1: Over-torque detection during constant speed operation, stop operation after detection.		
			2: Over-torque detection during constant speed operation, continue to operate after detection.		
			3: Over-torque detection during entire (acceleration, steady state,deceleration) operation, stop operation after detection		
			4: Over-torque detection during entire (acceleration, steady state,deceleration) operation, continue operation after detection.		
	Pr5-22	Over-Torque Detection Level 2 (ot2)	Amp(10~250% of drive's rated current)	##.##	

	Pr5-23	Over-Torque Detection Time 2 (ot2)	0.0~60.0 Sec	0.1	
	Pr5-24 {Pr5-21}	Most Recent Fault Record	0: no fault	0	
	Pr5-25 {Pr5-22}	2nd Most Recent Fault Record	1: oC (over-current)		
	Pr5-26 {Pr5-23}	3rd Most Recent Fault Record	2: oU (over-voltage)		
	Pr5-27 {Pr5-24}	4th Most Recent Fault Record	3: GF (ground fault)		
⊙	Pr5-28	5th Most Recent Fault Record	4: SC (IGBT failure)		
⊙	Pr5-29	6th Most Recent Fault Record	5: oL (drive overload)		
⊙	Pr5-30	7th Most Recent Fault Record	6: oL1 (electronic thermal relay 1)		
⊙	Pr5-31	8th Most Recent Fault Record	7: ot1 (Over-Torque1)		
⊙	Pr5-32	9th Most Recent Fault Record	8: oCn (over-current during constant speed)		
⊙	Pr5-33	10th Most Recent Fault Record	9: oCA (over-current during accel.)		
⊙	Pr5-34	11th Most Recent Fault Record	10: oCd (over-current during decel.)		
⊙	Pr5-35	12th Most Recent Fault Record	11: EP1 (EPROM error 1)		
⊙	Pr5-36	13th Most Recent Fault Record	12: EP2 (EPROM error 2)		
⊙	Pr5-37	14th Most Recent Fault Record	13: EF (external fault)		
⊙	Pr5-38	15th Most Recent Fault Record	14: Ct1 (current sensor 1)		
⊙	Pr5-39	16th Most Recent Fault Record	15: Ct2 (current sensor 2)		
			16: HPF (protection circuit fault)		
			17: oH1 (IGBT overheat)		
			18: oH2 (Heatsink overheat)		
			19: SoFt (Pre-charge circuit error)		
			20: ACI. (AI2 error)		
			21: ASC (RS-485 error)		
			22: PI.d (PID error)		
			23: Pu(Keypad communication overtime)		
			24: tunE (Auto tuning failure)		
			25: bF (braking chopper failure)		
			26: PG (PG error)		
			27: PHL (Phase-Loss protect or capacitor aged)		
			28: CC (current signal error during stop)		
			29: CPu (CPU error)		
			30: FAn (Fan failure)		
			31: AnI fault (Analog input error)		
			32: ot2 (Over-Torque2)	⊙	
			33: oL2 (electronic thermal relay 2)	⊙	
			34: rnot (Motor selection error)	⊙	
	36: LUr (Low Voltage during Run)	⊙			
	37: oUd (over-voltage during decel)				
	38: `x CoPY (Parameter copy error)	⊙			
	39: LU (Low Voltage)				
	40: bb (External Base Block)				
★ ⊙	Pr5-40	Full-Load Current of Motor 2	Amp (10~120% of drive's rated current)	##.##	
⊙	Pr5-41	Auto Torque Compensation of Motor 2	0.0~25.0%	0.0	
⊙	Pr5-42	Slip Compensation of Motor 2	0~20 RPM	0	
⊙	Pr5-43	Number of Motor Poles 2	2~20	4	
⊙	Pr5-44	Rotor Resistance R1 of Motor 2	0.000~65.535 Ω	0	
⊙	Pr5-45	Motor 2- Electronic Thermal Relay Selection (oL2)	0: Electronic thermal relay function disabled	0	
			1: Inverter duty motor (with independent cooling fan)		
			2: Standard motor (with shaft mounted cooling fan)		

⊙	Pr5-46	Motor 2- Electronic Thermal Relay Characteristic	30~600 Sec	60		
⊙	Pr5-47	Heatsink Over-Heat pre-warning setting (oH2)	0.0~110.0 °C	85.0		
⊙	Pr5-48	Delay Time for Motor Selection	0.00~60.00 Sec	0.05		
⊙	Pr5-49	Motor selection mode	Bit 0 (bxxxx0)	0	Cannot be switch during operation.	b00000
				1	Can be switch during operation.	
			Bit 1 (bxxxx0)	0	No need to waiting for confirm signal when switching	
				1	Need to waiting for confirm signal when switching	

Group 6: Special Parameters

	Parameters	Functions	Settings	Factory Setting	User
	Pr6-00	DC Braking Current Level	Amp (0~125% of drive's rated current)	##.##	
	Pr6-01	DC Braking Time during Start-up	0.00~60.00 Sec	0.00	
	Pr6-02	DC Braking Time during stopping	0.00~60.00 Sec	0.00	
	Pr6-03	Start-point for DC Braking during stopping	0.00~600.00 Hz (H1:00.0 ~6000.0Hz)	0.00	
	Pr6-04	Increasing Rate of the DC Braking Voltage	0.01~300.00%	20.00	
	Pr6-05	Momentary Power Loss Operation Selection	0 : Operation stops after momentary power loss.	0	
			1 : Operation continues after momentary power loss, speed search Speed Search starts with Last Output Frequency Downward		
			2 : Operation continues after momentary power loss, speed search starts with the Start-up frequency Upward		
	Pr6-06	Maximum Allowable Power Loss Time	0.1~5.0 Sec	2.0	
	Pr6-07	Base-Block Time for Speed Search (BB)	0.1~5.0 Sec	0.5	
	Pr6-08	Maximum Current Level for Speed Search	Amp(20~200% of drive's rated current)	##.##	
	Pr6-09	Deceleration Time for Speed Search	0.50~120.00 Sec	3.00	
	Pr6-10	Auto Restart after Fault	0~30 times	0	
	Pr6-11	Speed Search during Start-up	0 : speed search disabled	0	
			1 : speed search through the frequency command		
			2 : FWD-speed search only (motor only runs in FWD direction)		
			3 : REV-speed search only (motor only runs in REV direction)		
			4 : FWD/REV speed search enabled in both directions (FWD first)		
			5 : REV/FWD speed search enabled in both directions (REV first)		
	Pr6-12	Speed Search Frequency (FWD direction)	0.00~600.00 Hz (H1:00.0~6000.0Hz)	60.00/50.00	
	Pr6-13	Speed Search Frequency (REV direction)	0.00~600.00 Hz (H1:00.0 ~6000.0Hz)	60.00/50.00	
	Pr6-14	Dwell Time at Accel.	0.00~60.00 Sec	0.00	

Pr6-15	Dwell Frequency at Accel.	0.00~600.00 Hz (H1:00.0 ~6000.0Hz)	6.00
Pr6-16	Dwell Time at Decel.	0.00~60.00 Sec	0.00
Pr6-17	Dwell Frequency at Decel.	0.00~600.00 Hz (H1:00.0~6000.0Hz)	6.00
Pr6-18	Dwell Frequency current	Amp (0~150% of rated current)	###.##
Pr6-19	Traverse Skip Frequency	0.00~100.00Hz	0.00
Pr6-20	The Amplitude of traverse	0.00~200.00Hz	0.00

Group 7: High-function Parameters (PID and Communication)

Parameters	Functions	Settings	Factory Setting	User
Pr7-00	Proportional Gain (P)	0.0~500.0%	80.0	
Pr7-01	Integral Time (I)	0.00~100.00 Sec	1.00	
		0.00 : no integral		
Pr7-02	Derivative Control (D)	0.00~5.00 Sec	0.00	
Pr7-03	Upper limit for Integral Control	0.0~100.0%	100.0	
Pr7-04	PID Output Frequency Limit	0.0~100.0%	100.0	
Pr7-05	PID Offset	-100.0~+100.0%	0.0	
Pr7-06	Primary Delay Filter Time	0.000~0.100 Sec	0.000	
Pr7-07	PID Feedback Signal Detection Time	0.0~6000.0 Sec	0.0	
Pr7-08	Treatment of the Erroneous PID Feedback Signals	0: warn and keep operating	0	
		1: warn and RAMP to stop		
		2: warn and COAST to stop		
Pr7-9	Treatment of Keypad Transmission Fault	0: Warn and RAMP to stop	0	
		1: Warn and COAST to stop		
Pr7-10	Keypad Transmission Fault detection	0.0: Disable and keep operating	0.0	
		0.1~60.0 Sec		
Pr7-11	Communication Address	1~254	1	
Pr7-12	Transmission Speed (Baud rate)	1.2~125 Kbps	9.6	
Pr7-13	Transmission Fault Treatment	0: warn and keep operating	3	
		1: warn and RAMP to stop		
		2: warn and COAST to stop		
		3: No warning and keep operating		
Pr7-14	Time-out Detection	0.0: disabled	0.0	
		0.1~60.0 Sec		
Pr7-15	Communication Protocol	0 : 7,N,2 ASCII	0	
		1 : 7,E,1 ASCII		
		2 : 7,O,1 ASCII		
		3 : 7,E,2 ASCII		
		4 : 7,O,2 ASCII		
		5 : 8,N,1 ASCII		
		6 : 8, N,2 ASCII		
		7 : 8,E,1 ASCII		
		8 : 8,O,1 ASCII		
		9 : 8,E,2 ASCII		
		10 : 8,O,2 ASCII		
		11 : 8,N,1 RTU		
		12 : 8,N,2 RTU		
		13 : 8,E,1 RTU		
		14 : 8,O,1 RTU		
		15 : 8,E,2 RTU		
16 : 8,O,2 RTU				

Group 8: Fan & Pump Control Parameters

Parameters	Functions	Settings	Factory Setting	User
★ Pr8-00	V/F Curve Selection	0: V/F Curve determined by Parameter Group 1 1: 1.5 Power Curve 2: Square Power Curve	0	
Pr8-01	Start-Up Frequency of the Auxiliary Motor	0.00~600.00 Hz (H1:00.0 ~6000.0Hz)	0.00	
Pr8-02	Stop Frequency of the Auxiliary Motor	5.00~600.00 Hz (H1:50.0 ~6000.0Hz)	5.00	
Pr8-03	Time Delay before Stopping the Auxiliary Motor	0.0~6000.0 Sec	0.00	
Pr8-04	Time Delay before Stopping the Auxiliary Motor	0.0~6000.0 Sec	0.00	
Pr8-05	Sleep Frequency	0.00~600.00 Hz (H1:00.0~6000.0Hz)	0.00	
Pr8-06	Wake-up Frequency	0.00~600.00 Hz (H1:00.0~6000.0Hz)	0.00	
Pr8-07	Sleep Time	0.0~6000.0 Sec	0.0	

Group 9: Speed Feedback Control Parameters

(A PG Feedback Card (optional) is necessary for setting those parameters)





Parameters	Functions	Settings	Factory Setting	User
★ Pr9-00	PG Pulses	1~5000 PPR	1024	
★ Pr9-01	PG Type and Function setting	0 : Disable PG 1: Bidirection, Phase A leads in a forward run command and phase B leads in a reverse run command 2: Bidirection, Phase B leads in a forward run command and phase A leads in a reverse run command 4: As PID feedback (REV) 5: As PID feedback (FWD) 8: Frequency command (REV) (Pr0-18=4) 9: Frequency command (FWD) (Pr0-18=4)	0	
★ Pr9-02	PG Speed Feedback Display Filter	0.000~1.000sec	0.03	
Pr9-03	PG feedback speed control Proportional Gain (P)	0.0~500.0%	20.0	
Pr9-04	PG feedback speed control Integral Time (I)	0.00~10.00 Sec 0.00 : no integral	0.50	
Pr9-05	PG feedback speed control Differential (D) Time	0.00~5.00 Sec	0.00	
Pr9-06	PG Speed Control Output Frequency Limit	0.00~150.00Hz	20.00	
Pr9-07	Treatment of PG Feedback Fault	0: warn and keep operating 1: warn and RAMP to stop 2: warn and COAST to stop	0	
Pr9-08	PG Feedback Fault Detection Time	0.00~10.00 Sec	0.10	
Pr9-09	PG Feedback compensation limit	0~900 RPM	90	

ERROR MESSAGE AND TROUBLESHOOTING

The drive has a comprehensive fault diagnostic system that includes various alarms and fault messages such as over-voltage, low-voltage and over-current....etc. Once a fault is detected, the corresponding protective functions will be activated, and the drive will stop the output and the motor will then coast to stop. The following faults are displayed as shown on the drive digital keypad panel. Once the fault occurred, eliminate it first, and wait for 5 seconds (oC,GF,SC are 60 seconds) then execute RESET action to reactivate the operation.

User may either by depress RESET key on the keypad or apply a external reset signal from Mix to execute RESET action.

Problems and Solutions

Fault symbol	Fault descriptions (Name) {Error code}	Treatments
	Over- current (oC) {01} The drive detects an abnormal increase in output current.	<ul style="list-style-type: none"> ◆ Check the wiring connections between the drive and motor for possible short circuits. ◆ Increase the Acceleration time (Pr1-11, Pr1-12) ◆ Check for possible excessive loading conditions at the motor. ◆ Replace the drive with the next higher power model ◆ Wait for 60 seconds then execute RESET action to reactivate the operation.
	Over-voltage on DC-Bus (oU) {02} The drive detects that the DC bus voltage has exceeded its maximum allowable value. 115/230 V class: about 400V 460 V class: about 800V 575 V class: about 1040V	<ul style="list-style-type: none"> ◆ Check whether the input voltage falls within the rated drive input voltage range. ◆ Check for possible voltage transients. ◆ If DC Bus over-voltage due to regenerative voltage, please increase the Deceleration time or add an brake unit and brake resistor (optional)
	Over-voltage on DC-Bus during deceleration (oUd) {37} The drive detects that the DC bus voltage has exceeded its maximum allowable value while in deceleration. 115/230 V class: about 400V 460 V class: about 800V 575 V class: about 1040V	<ul style="list-style-type: none"> ◆ Check whether the input voltage falls within the rated drive input voltage range. ◆ If DC Bus over-voltage due to regenerative voltage, please increase the Deceleration time or add an brake unit and brake resistor (optional) ◆ Check whether the required braking power is within the specified limits.
	Ground fault (GF) {03}: When (one of) the output terminal(s) is grounded, short circuit current is more than 50% of drive rated current, the drive power module may be damaged. NOTE: The Ground fault protection is provided for drive protection, not for protection of the user..	<ul style="list-style-type: none"> ◆ Check the wiring connections between the drive and motor for possible short circuits, also to ground ◆ Check whether the IGBT power module is damaged. ◆ Check for possible poor insulation at the output line ◆ Wait for 60 seconds then execute RESET action to reactivate the operation.

<p>SC</p>	<p>IGBT fault (SC) {04}</p> <p>IGBT module switching failure is detected.</p>	<ul style="list-style-type: none"> ◆ Check whether the motor's resistance and insulation are functioning right ◆ Check whether the connection to the motor is short circuited ◆ Disconnect the cable between the drive and motor, then run again, If the fault code is still displayed then IGBT module should be failure---please return to the factory ◆ Wait for 60 seconds then execute RESET action to reactivate the operation.
<p>OL</p>	<p>Drive overload (OI) {05}</p> <p>The drive detects excessive drive output current. G1, H1 Series: The drive can withstand up to 150 % of the rated current for a maximum of 60 seconds. P1 Series: The drive can withstand up to 125% of the rated current for a maximum of 60 seconds.</p>	<ul style="list-style-type: none"> ◆ Check whether the motor is overloaded ◆ Reduce torque compensation setting as set in Pr5-01 ◆ Increase the acceleration time ◆ Replace the drive with the next higher power model
<p>OL I</p>	<p>Motor overload -Thermal relay 1 (oL1) {06}</p> <p>(Electronic thermal relay 1 protection.)</p>	<ul style="list-style-type: none"> ◆ Check whether the motor 1 V/F setting proper ◆ Check whether the motor 1 running low speed for long period ◆ Check for possible motor 1 overload ◆ Check motor 1 full load current (Pr5-00) ◆ Check electronic thermal overload 1 setting (Pr5-18 to Pr5-19) ◆ Reduce the load so that the drive output current does not exceed the value set on Pr5-00 ◆ Increase motor capacity
<p>OT I</p>	<p>Over-Torque1 detected (ot1) {07}</p>	<ul style="list-style-type: none"> ◆ Check whether the motor 1 is overloaded ◆ Check whether motor 1 rated current setting (Pr5-00) is suitable ◆ Check whether the Over-Torque1 detect parameter are suitable (Pr5-15~Pr5-17) ◆ Check whether the mechanical system is normal ◆ Increase motor 1 capacity and replace the drive with the next higher power model
<p>oCn</p>	<p>Over-current during constant speed (oCn) {08}</p>	<ul style="list-style-type: none"> ◆ Check for possible poor insulation at the output wires ◆ Check for possible motor stall ◆ Replace the drive with the next higher power model.
<p>oCA</p>	<p>Over-current during acceleration (oCA) {09}</p>	<ul style="list-style-type: none"> ◆ Check for possible poor insulation at the output wires ◆ Decrease the torque boost setting in Pr5-01 ◆ Increase the acceleration time ◆ Replace the drive with the next higher power model.
<p>oCd</p>	<p>Over-current during deceleration (oCd) {10}</p>	<ul style="list-style-type: none"> ◆ Check for possible poor insulation at the output wires ◆ Increase the deceleration time ◆ Replace the drive with the next higher power model
<p>EP I</p>	<p>EPROM read error (EP1) {11}</p>	<ul style="list-style-type: none"> ◆ Check whether the power voltage falls within the rated voltage

EP2	EPROM write error (EP2) {12}	<ul style="list-style-type: none"> ◆ Switch off power supply wait until display off then on again. ◆ Reset drive to factory defaults, return to the factory if not working
EF	External fault (EF) {13} (one of Pr2-01~Pr2-06 or Pr2-26~Pr2-28 =14 and act)	<ul style="list-style-type: none"> ◆ Give RESET command after fault has been cleared Input
Ct1	U phase current sensor A/D fault (Ct1) {14}	<ul style="list-style-type: none"> ◆ Switch off power supply wait until display off then on again ,If fault code is still displayed please return to the factory. ◆ Eplace a control board or U phase current sensor
Ct2	W phase current sensor A/D fault (Ct2) {15}	<ul style="list-style-type: none"> ◆ Switch off power supply wait until display off then on again ,If fault code is still displayed please return to the factory. ◆ Eplace a control board or W phase current sensor
HPF	Hardware protection loop fault (HPF) {16}	<ul style="list-style-type: none"> ◆ Switch off power supply wait until display off then on again ,If fault code is still displayed please return to the factory.
oH1	IGBT overheat (oH1) {17} IGBT temperature exceeds protection level	<ul style="list-style-type: none"> ◆ Check the cooling fan and clean it ◆ Ensure that the ambient temperature falls within the specified ◆ Remove any foreign objects on the heat sinks and check for possible dirty heat sink fins. ◆ Make sure that the ventilation path is not obstructed. ◆ Provide enough spacing for adequate ventilation.
oH2	Environment overheat (oH2) {18} The drive temperature sensor detects excessive heat on environment.	<ul style="list-style-type: none"> ◆ Ensure that the ambient temperature falls within the specified ◆ Provide enough spacing for adequate ventilation. ◆ Ensure that the cabinet ventilation path is not obstructed where the drive is installed.
SoFt	Inrush limit circuit fault (SoFt) {19}	<ul style="list-style-type: none"> ◆ Switch off power supply wait until display off then on again, If fault code is still displayed please return to the factory.
AC1	Analog input signal lost (AC1.) {20}	<ul style="list-style-type: none"> ◆ Check if the AC1 signal is less than 4mA ◆ Check the AI2 wiring
ASC	RS-485 serial port time-out (ASC) {21}	<ul style="list-style-type: none"> ◆ Check the RS-485 wiring
PI.d	PID feedback error (PI.d) {22}	<ul style="list-style-type: none"> ◆ Check the PID feedback wiring ◆ Check the PID parameters settings ◆ Check if parameters are properset when it is PG feedback control.
Pu	PU communication error (Pu) {23}	<ul style="list-style-type: none"> ◆ Check whether the keypad communication circuit is well-conducted
tunE	Auto tuning failure (tunE) {24}	<ul style="list-style-type: none"> ◆ Check cabling between drive and motor. ◆ Check whether the motors horsepower corresponds to the drive output power. ◆ Retry again

bF	Braking chopper fault (bF) {25}	<ul style="list-style-type: none"> ◆ Switch off power supply wait until display off then on again, If fault code is still displayed please return to the factory.
PG	PG error (PG) {26}	<ul style="list-style-type: none"> ◆ Check the wiring of the PG feedback. ◆ Check whether the motor is blocked
PHL	<p>Phase-Loss protect or capacitor aged (PHL) {27}</p> <p>Three phase imbalanced at the input voltage or the drive detects excessive ripple voltage on DC-Bus</p>	<p>Caused of power source:</p> <ul style="list-style-type: none"> ◆ Check whether the power voltage is normal ◆ Check whether the screw at the input power terminal is tightened ◆ Check whether the power source phase-lacking <p>Caused of smoothing capacitor:</p> <ul style="list-style-type: none"> ◆ Check whether the smoothing capacitors life is ended.
CC	Current signal error during stop (CC) {28}	<ul style="list-style-type: none"> ◆ Reset the drive, if okay, then might be interference noise come into the drive. ◆ Return to the factory if previous method is not effect.
CPu	CPU error (CPu) {29}	<ul style="list-style-type: none"> ◆ Switch off power supply wait until display off then on again, If fault code is still displayed please return to the factory.
FAn	Fan fault (FAn) {30}	<ul style="list-style-type: none"> ◆ Check whether the cooling fan is blocked ◆ Replace the fan
An1	Analog input error (An1.) {31}	<ul style="list-style-type: none"> ◆ Check if the analog input signal is out of range
ot2	Over-Torque2 detected (ot2) {32}	<ul style="list-style-type: none"> ◆ Check whether the motor 2 is overloaded ◆ Check whether motor 2 rated current setting (Pr5-40) is suitable ◆ Check whether the Over-Torque2 detect parameter are suitable (Pr5-21~Pr5-23) ◆ Check whether the mechanical system is normal ◆ Increase motor 2 capacity and replace the drive with the next higher power model
oL2	<p>Motor overload -Thermal relay 2 (oL2) {33}</p> <p>(Electronic thermal relay 2 protection.)</p>	<ul style="list-style-type: none"> ◆ Check whether the motor 2 V/F setting proper ◆ Check whether the motor 2 running low speed for long period ◆ Check for possible motor 2 overload ◆ Check motor 1 full load current (Pr5-40) ◆ Check electronic thermal overload 1 setting (Pr5-45 to Pr5-46) ◆ Reduce the load so that the drive output current does not exceed the value set on Pr5-40 ◆ Increase motor capacity
rnot	Motor select error (rnot) {34}	<ul style="list-style-type: none"> ◆ Check the motor wiring connection ◆ Check the parameters settings
LUr	<p>Low voltage on DC-Bus during run (LUr) {36}</p> <p>The drive detects that the DC bus voltage has fallen below its minimum value during run</p>	<ul style="list-style-type: none"> ◆ Check whether the input power voltage is normal ◆ Check whether the power supply capacity is enough ◆ Check for possible sudden load ◆ Whether the 3-phase model is of the single-phase power input or the phase-lacking
LU	<p>Low voltage on DC-Bus (LU) {39}</p> <p>The drive detects that the DC bus voltage has fallen below its minimum value</p>	<ul style="list-style-type: none"> ◆ Check whether the Inrush limit by-pass circuit fault ◆ Check whether the input power was interrupted ◆ Check whether the input side magnetic contactor is normal

	<p>External Base Block (bb) {40} (one of Pr2-01~Pr2-06 or Pr2-26~Pr2-28 =15 or 16 and act)</p>	<ul style="list-style-type: none"> ◆ When the external input terminal (B.B) is active, the drive output will be turned off. ◆ Deactivate the external input terminal (B.B) to operate the drive again.
	<p>EEPROM of PU-02 failure (1 CoPy)</p>	<ul style="list-style-type: none"> ◆ Replace a PU-02
	<p>Nothing to save due to PU-02 is empty (2 CoPy)</p>	<ul style="list-style-type: none"> ◆ Make sure PU-02 had read data then try again
	<p>Cannot Save due to drive model is not the same (3 CoPy)</p>	<ul style="list-style-type: none"> ◆ Recheck the drive models
	<p>Parameter error in PU-02 (4 CoPy)</p>	<ul style="list-style-type: none"> ◆ Parameter is out of range, recheck the Parameter in PU-02
	<p>Cannot Save due to drive is running (7 CoPy)</p>	<ul style="list-style-type: none"> ◆ Stop the drive then try again
	<p>Cannot Save or Read due to drive was password locked (8 CoPy)</p>	<ul style="list-style-type: none"> ◆ Unlock the drive then try again

Dimension:

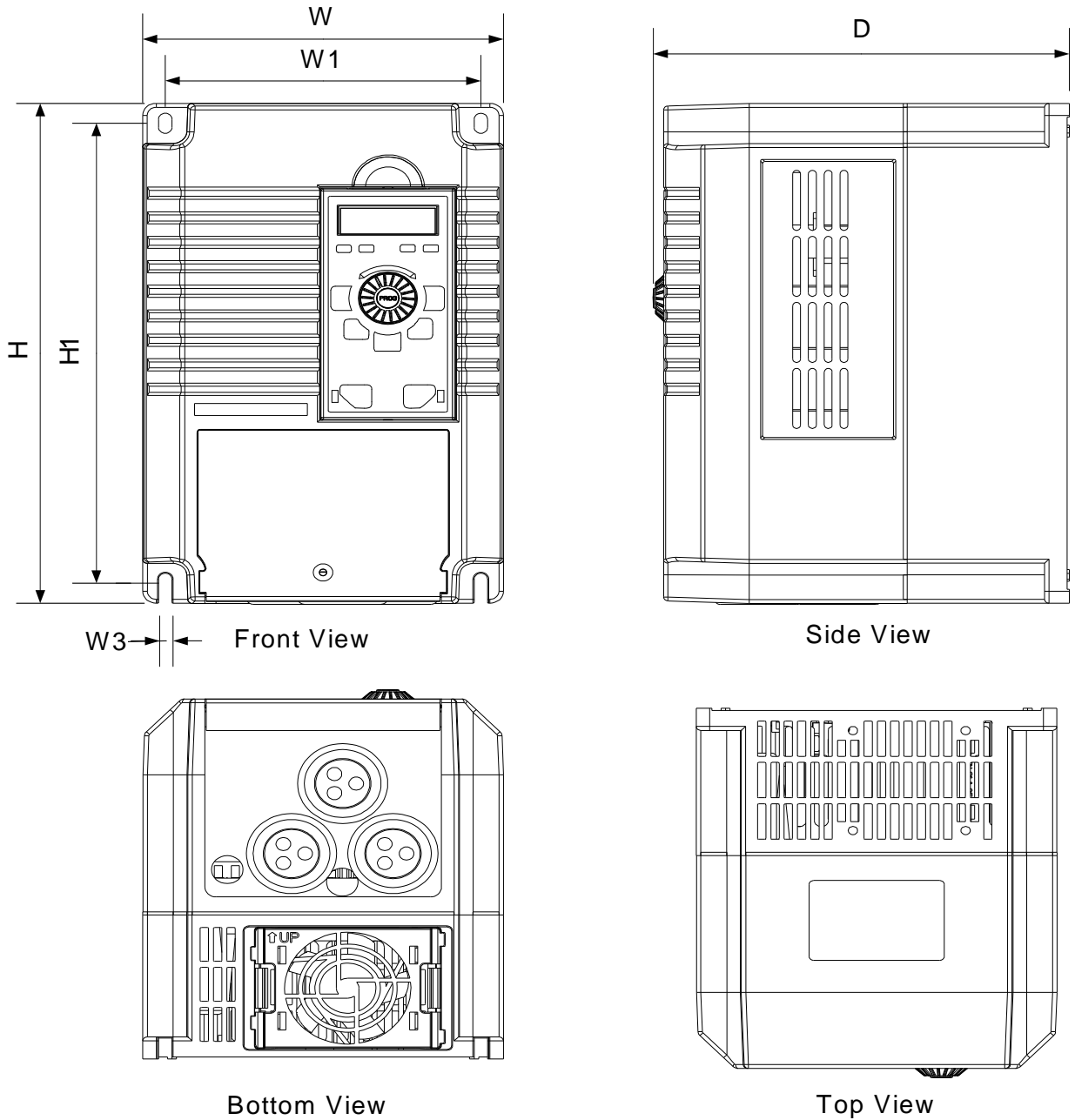

Unit: mm (inch)

Frame	W	H	D	W1	W3	H1
G1-A,H1-A,P1-A	160.0 (6.30)	250.0 (9.84)	186.0 (7.32)	140.0 (5.51)	6.0 (0.24)	230.0 (9.06)
G1-B,H1-B,P1-B	200.0 (7.87)	275.0 (10.83)	206.0 (8.11)	180.0 (7.87)	6.0 (0.24)	255.0 (10.83)
G1-C,H1-C,P1-C	260.0 (10.24)	460.0 (18.11)	245.0 (9.65)	236.0 (9.29)	9.0 (0.35)	440.0 (17.32)

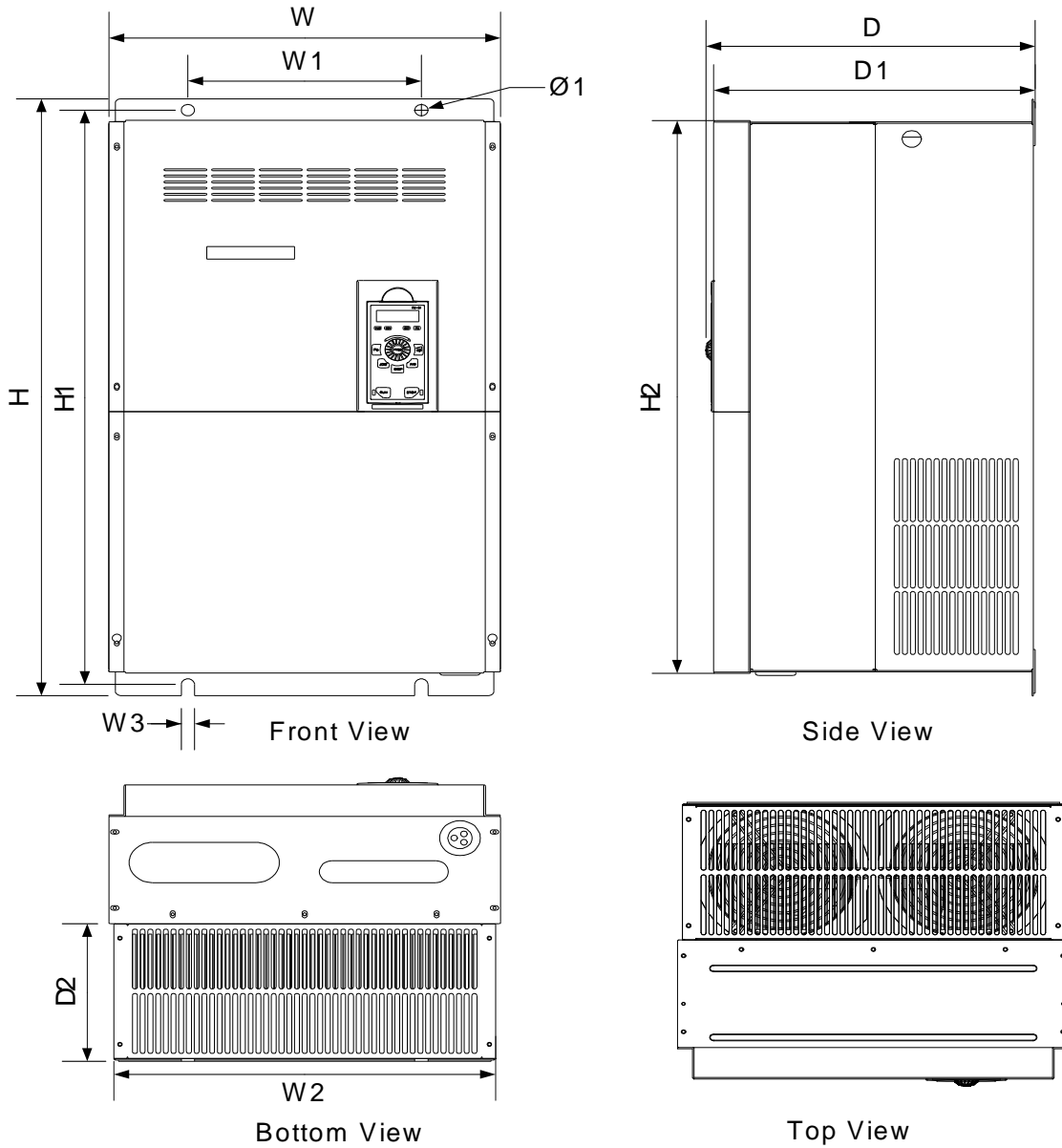



Unit: mm (inch)

Frame	W	H	D	W1	W2	W3	H1	H2	D1	D2	Φ1
G1-D H1-D P1-D	386.0 (15.20)	617.0 (24.29)	298.3 (11.74)	230.0 (9.06)	376.0 (14.80)	13.0 (0.51)	591.5 (23.29)	566.5 (22.30)	290.5 (11.44)	131.5 (5.18)	13 (0.51)
G1-E H1-E P1-E	386.0 (15.20)	683.0 (26.89)	324.3 (12.77)	230.0 (9.06)	376.0 (14.80)	13.0 (0.51)	657.5 (25.89)	632.5 (24.90)	316.5 (12.46)	157.5 (6.20)	13 (0.51)
G1-F H1-F P1-F	496.0 (19.53)	810.0 (31.89)	352.1 (13.86)	260.0 (10.24)	484.0 (19.06)	13.0 (0.51)	784.0 (30.87)	764.0 (30.08)	344.0 (13.54)	180.5 (7.11)	13 (0.51)
G1-G H1-G P1-G	732 (28.82)	1196 (47.09)	413 (16.26)	410 (16.14)	720.0 (28.35)	13.0 (0.51)	1156 (45.51)	1133 (44.61)	404.9 (15.94)	177.30 (6.98)	13 (0.51)
G1-H H1-H P1-H											

序言

感謝您採用陽岡科技所製造的高性能，電流向量變頻器 TOPVERT G1/H1/P1 等系列產品。TOPVERT G1/H1/P1 系列產品採用了高品質之元件、材料及融合最新的微電腦控制技術製造而成。本手冊提供給使用者安裝、參數設定、異常診斷、異常排除及日常維護相關注意事項。為了確保能夠正確地安裝及操作變頻器，請在裝機之前，詳細閱讀本使用手冊，並請交由該機器的使用者。此次使用說明書的更新，除了修改了前 8701 版本的錯別字及不適合的用詞以外，我們也儘量加註了更多解譯字詞，期望使用者能一閱即明瞭，我們也在多個參數位置有相關連的地方加註了指引，期望使用者能容易上手。然而最重大的不同在於韌體版本升級至 3.xx 版本所造成的差異。茲表列二者之主要差異如下：

- 2.xx 版本韌體及硬體新增加的部份(在參數位置會以  標示之)
- 3.xx 版本韌體及硬體新增加的部份(在參數位置會以  標示之)

	修改或新增功能內容	相關參數位置
1	原+12V 輸出電壓源更名為+VX, 並改成+12V/+10V 可切換的電壓源, 參考點為 ACM。	
2	原多功能類比輸入 AVI 更名為 AI1, 並可在電壓/電流信號間切換。	Pr3-02 ~ Pr3-05
3	原多功能類比輸入 ACI 更名為 AI2, 並可在電壓/電流信號間切換。	Pr3-06 ~ Pr3-10
4	原多功能類比輸入 AUI 更名為 AI3, 可接入 DC -10~+10V 電壓信號。	Pr3-11 ~ Pr3-14
5	原多功能類比輸出 AVO 更名為 AO1, 可輸出 DC 0~10V 電壓信號。	Pr3-15, Pr3-17, Pr3-19, Pr3-21
6	原多功能類比輸出 ACO 更名為 AO2, 並可在電壓/電流信號間切換。	Pr3-16, Pr3-18, Pr3-20, Pr3-21
7	原 RS-485 串列通訊埠的 RJ-45 插座修改為可插拔式歐式端子。	(SG+, SG-)
8	修改了散熱風扇控制出廠預設模式為”運轉命令執行後風扇才運轉”。	Pr0-23
9	所有控制端子改成可插拔式, 並依類別群聚及防呆, 方便配線及維修。	
10	增加了運轉中 JOG 命令有效或無效之選擇。	Pr4-36 bit 4
11	增加了一個 DCM 端子, 方便配線。	
12	增加了 R2B 端子。	Pr2-21
13	增加了 PU-03 的介面, 與 PU-01 及 PU-02 同接口, 並且自動辨識。	
14	增加了8個可選配的端子如下: [需加配擴充卡 TMCA-IO-10 才有此功能]	
	[MI7] [多功能數位輸入端子 7]	Pr2-26
	[MI8] [多功能數位輸入端子 8]	Pr2-27
	[MI9] [多功能數位輸入端子 9]	Pr2-28
	[AO3] [多功能類比輸出 3] (可輸出 4(0)~20mA 電流信號)	Pr3-15
	[MO3] [多功能數位輸出 5 - 開集極輸出端子 MO 3+]	Pr2-24
	[MC3] [多功能數位輸出 5 - 開集極輸出端子 MO 3-]	
	[MO4] [多功能數位輸出 6 - 開集極輸出端子 MO 4+]	Pr2-25
[MC4] [多功能數位輸出 6 - 開集極輸出端子 MO 4-]		

版權聲明

本文件中的資料係陽岡科技的智慧財產，我們雖然盡了最大的努力製作此文件，但無法對內容的正確性提供百分之百保證，基於“還能更好”的品質政策，我們的產品恆於追求完美精益求精的路途中，因此我們保留了不告知變動的權利，但我們持續將最新版本的文件擺在陽岡科技的公司網站上，供自由下載。

<http://www.toptek.biz>

本使用說明書，煩請您確實交給本變頻器之最終使用者，以便發揮最大功能。謝謝！

變頻器乃精密的電力電子產品，為了操作者及機械設備的安全，請務必交由專業的電機工程人員安裝試車及調整參數，本手冊中有“危險”、“注意”等符號說明的地方請務必仔細研讀，若有任何疑慮的地方請連絡本公司各地的代理商洽詢，我們的專業人員會樂於為您服務。

以下為特別需要注意的事項：



1. 實施配線，務必關閉電源。
2. 切斷交流電源後，充電指示燈(CHARGE)未熄滅前，表示變頻器內部仍有高壓，十分危險，請勿觸摸內部電路及零組件。
3. 絕對不可以自行改裝變頻器內部的零件或線路。
4. 絕不可將變頻器輸出端子U/T1、V/T2、W/T3 連接至AC 電源。
5. 變頻器接地端子  務必正確的接地，230V 機種採第三種接地；460V /575V 機種採特種接地。



1. 切勿對變頻器內部的零組件進行耐壓測試，因內有半導體易受高壓擊穿而損壞。
2. 變頻器的電路板有cmos IC 極易受靜電的破壞，故在未做好防靜電措施前請勿用手觸摸電路板。
3. 即使電動機是停止的，變頻器的主回路端子仍然可能有危險的高壓。
4. 只有合格的電機專業人員才可以安裝、配線及修理保養變頻器。
5. 當變頻器某些功能被設定後，可能在電源輸入後會立即啟動電動機開始運轉。
6. 請選擇安全的區域來安裝變頻器，防止高溫及日光直接照射，避免溼氣和水滴的潑濺。
7. 請防止小孩或一般無關人員接近變頻器。
8. 變頻器只能用在本公司所認可的場合，未經認可的使用環境可能導致火災、氣爆、感電等事件。
9. 當變頻器與電動機之間的配線過長時，對電動機的層間絕緣可能產生破壞，請改用變頻器專用的交流電動機，或在變頻器及電動機之間加裝電抗器或濾波器，避免造成交流電動機因絕緣破壞而燒毀。（電抗器或濾波器之選用請參閱使用手冊 3-5章節）。
10. 變頻器所安裝之電源系統額定：（230V級機種不可高於240V），（460V級機種不可高於480V），（575V級機種不可高於640V），供應容量電流不可超大於5000A RMS（30kW 以上機種不可大於10000A RMS）
11. 變頻器機殼對大地的漏電流（High leakage current）為22 mA。
12. 變頻器所控制的電動機應符合 IEC:60034-1。
13. 變頻器在開機瞬間充電電阻會有微量煙霧發生，屬正常現象。

交貨檢查

機型銘牌說明

以 G1系列 2.2kW/3Hp 230V 3 Phase 選配 動態煞車器及速度迴授PG卡 為例：

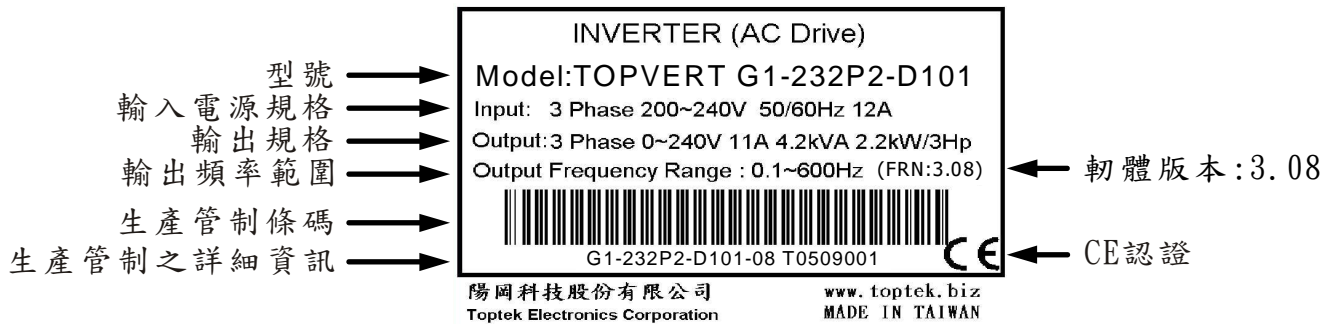

型號說明

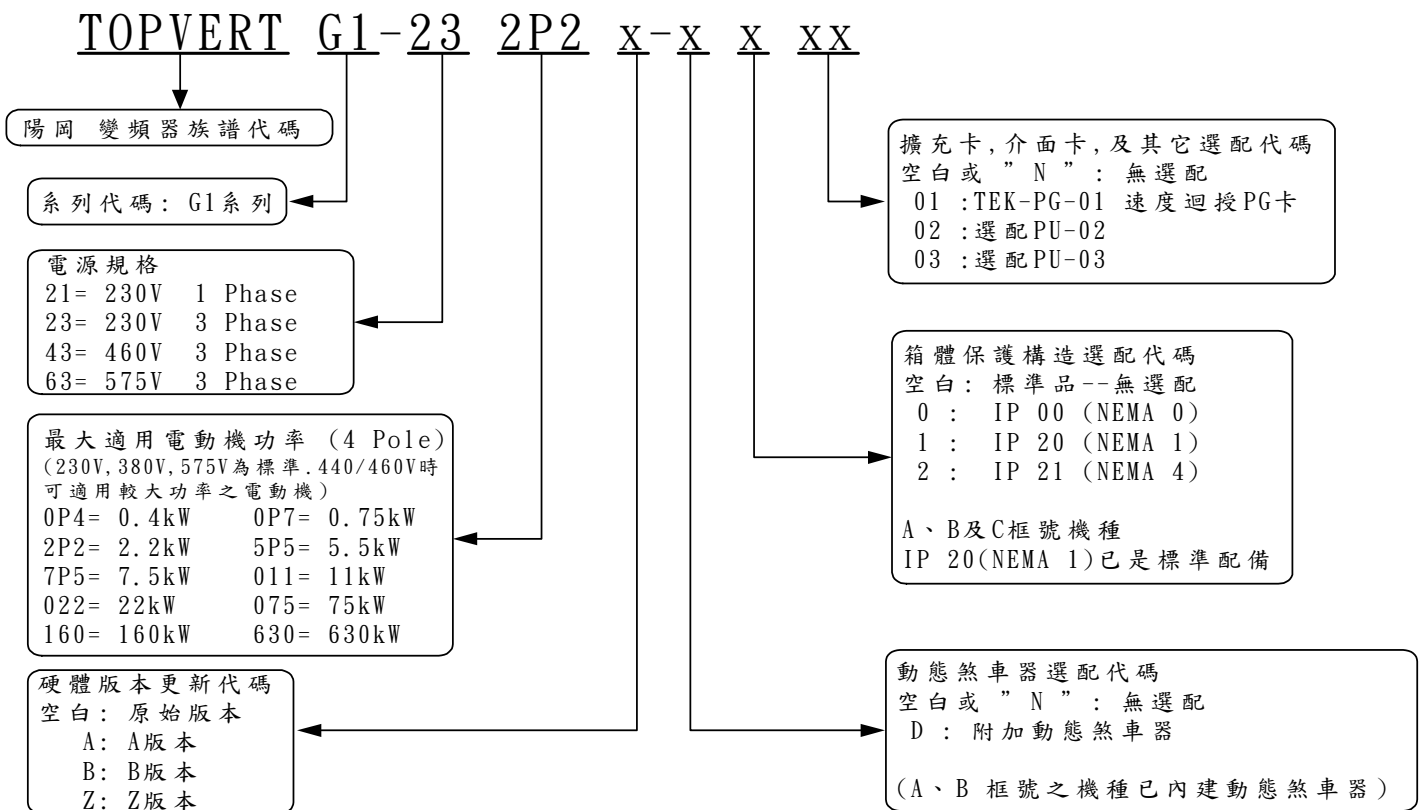

生產管制之資訊說明

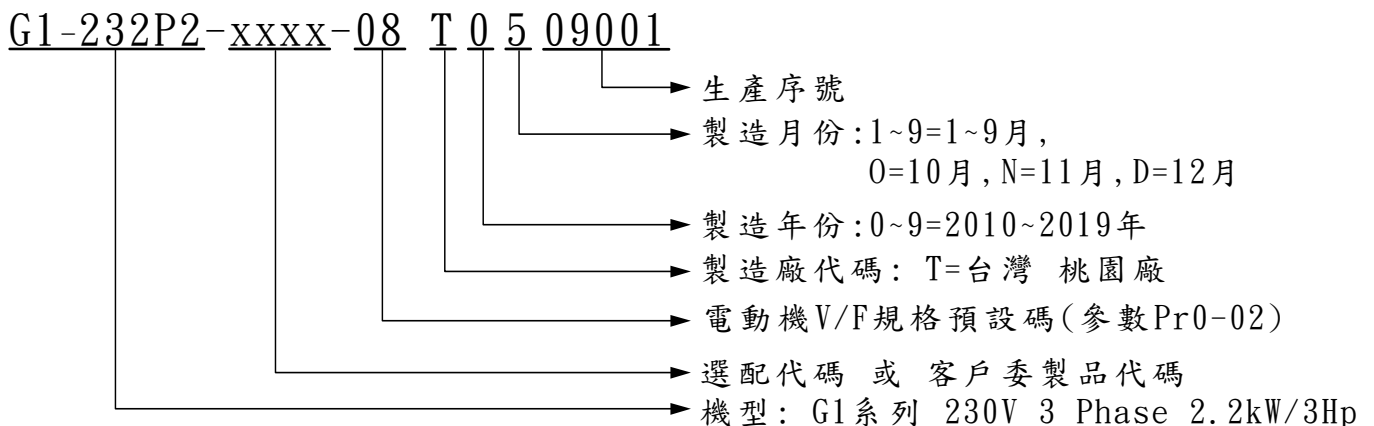

● 拆裝後如有任何登錄資料與您訂貨資料不符或有任何瑕疵, 請您與接洽之代理商或經銷商聯絡。

標準規格

系列名稱		TOPVERT G1 系列 全功能泛用標準型	TOPVERT H1 系列 全功能高速專用型	TOPVERT P1 系列 全功能風機水泵專用型
輸出及控制	輸出頻率範圍 [1]	0-600Hz, 可規劃, 0.01Hz/step	0-6000Hz, 可規劃, 0.01Hz/step	0-600Hz, 可規劃, 0.01Hz/step
	過負載承受能力 [2]	額定輸出電流的150%(PI為125%), 運轉60秒/10分鐘, Ta≤50℃, 200%(PI為160%)運轉3秒, 適用連續性負載。		
	輸出電壓 [3]	對應輸入電源0-100%的電壓, 三相輸出, 內建自動穩壓器(AVR), 電源變動仍俱滿載額壓輸出驅動能力。		
	功因及效率 [4]	裝置之功率因數不低於0.95, 裝置全載時之效率不低於95%, 22kW以上之機種可達97%。		
	控制方式 [5]	正弦波 Soft PWM 調變磁通電壓/電流向量控制, 俱電動機參數自動調適(Auto-tuning)及高速 IGBT 六橋輸出架構。		
	控制模式與控速範圍 [6]	四種模式可切換, V/F 模式 20:1; V/F+PG 閉迴路模式 120:1; 無感向量模式 120:1; 磁束向量+PG(閉迴路模式 600:1)		
	頻率設定解析度 [7]	類比輸入: 10Bit(1/1024), 0.03Hz/60Hz, 0.024Hz/50Hz, 數位輸入: 0.01Hz(±0.01%), 飛梭旋鈕輸入: 0.01Hz。		
	頻率設定精準度 [8]	類比輸入: 最大輸出頻率之±0.03%以內(25℃ ±10℃); 數位輸入: 最大輸出頻率之 0.01%以內(-10℃ ~ +50℃)		
	PWM 載波頻率 [9]	0.7kHz ~ 18kHz 運轉中可連續調整	1.4kHz ~ 36kHz 運轉中可連續調整	0.7kHz ~ 18kHz 運轉中可連續調整
	轉矩提升 [10]	內建可調式及自動轉矩提升(Torque boost)及自動滑差補償, 1Hz 時可達額定轉矩的150%, 起動轉矩可達200%。		
	共振迴避(跳躍)頻率 [11]	自 0.00 ~ 600Hz (H1 系列: 0.00 ~ 6000 Hz)可任意設定6組, 各組之寬度皆獨立可調。		
	加速/減速時間 [12]	0.01 ~ 60000 秒 (2段 加速/減速 時間可分別獨立設定, 另俱 S 曲線加/減速及自動最佳化加/減速時間功能)		
	失速防止 [13]	過電流失速防止: 10 ~ 250%可調, 加速中及定速運轉中可分別獨立設定, 過電壓失速防止: 100 ~ 160%可調。		
	直流煞車 [14]	啟動時及停止時, 都可直流煞車, 制動電流: 額定電流的 0 ~ 125%, 制動時間: 0 ~ 60 秒獨立設定, 制動起始頻率 0 ~ 600Hz		
	動態煞車 [15]	動態煞車轉矩大約 20%(10% E.D.), A 及 B 框號之機型, 煞車迴路已內建, 其餘機型之煞車迴路可選配內建全系列都可外接動態煞車器(TDBU-XXXX) (外接動態煞車器時煞車轉矩可達125%)		
	V/F 曲線 [16]	可由使用者自定的二組任意 V/F 曲線, 可設定成轉矩特性曲線或遞減轉矩特性曲線。		
運轉操作及輸入/輸出界面	頻率設定方式/信號源 [17]	由數位操作器 [17] 以 360 度編碼器式飛梭旋鈕設定(分辨率 0.01Hz/0.1Hz/1Hz/10Hz 可規劃), 寸動鍵運轉設定, [定時運轉/停止]		
	信號源 [18]	由類比信號 [18] 可任意規劃為: 0~10/10~0V, 4~20/20~4mA, -10~+10V(可逆運轉), 1~5/5~1V, 0~20/20~0mA, 或由外部可變電阻。		
		由數位信號 [19] 端子 MI1-MI6 (15 段速, 寸動, Up/Down 指令), 可程式運轉(PLC Run), 通訊設定(RS-485), 信號間並可任意切換。		
	運轉操作信號 [20]	由數位操作器 [20] 可由 RUN, STOP, JOG 鍵執行, 也可與外部端子切換/並用。		
		由外部信號 [21] FWD/REV/STOP (2 線式運轉, 3 線式運轉), 寸動運轉, 可程式運轉(PLC Run), 通訊設定(RS-485)。		
	可規劃的智慧型多功能輸入端子 [22]	8 組數位輸入 (DI) [可擴充至 11 組] [22] 接點皆可規劃為 a 或 b 接點, 並可規劃成下列功能: 16 段可預設速度切換, 第 1/2 加減速時間切換, 禁止加減速, 計數輸入, 暫時停機, 外部輸出遮斷, 輔助電動機控制失效, AI2/AI1 選擇, 變頻器重置, 15 段可程式運轉, 寸動運轉, 遞增/遞減頻率端子設定, Sink/Source 選擇, 馬達過熱保護, 參數群選擇...等多達 43 種功能。		
		3 組類比輸入 (AI) [23] AI1: 0~10V/4~20mA (輸入阻抗 20kΩ/250Ω), AI2: 4~20mA/0~10V (輸入阻抗 20kΩ/250Ω), AI3: -10~+10V(輸入阻抗 10kΩ) (也可規劃成 4~20mA), 俱斷線偵測, 都可規劃成對應 16 種不同功能。		
	可規劃的智慧型多功能輸出端子 [24]	4 組數位輸出 (DO) [可擴充至 6 組] [24] 接點皆可規劃為 a 或 b 接點, 由 2 個 "C" 接點的繼電器, 及 2 個開集極輸出端子(可擴充至 4 組)所組成, 並可規劃成下列功能: 運轉中, 停止中, 頻率到達輸出, 零速指示, 可程式運轉, 計數到達指示, 過轉矩, 外部輸出中斷, 多組輔助電動機控制, 輸出低電壓報警, 操作模式, 故障指示, 變頻器準備完成, 過熱預警, 緊急停止, 可規劃的數位脈衝信號輸出...等多達 63 種功能及配合監控功能提供信號輸出。		
		2 組類比輸出端子(AO) [25] AO1: 0~10V, AO2: 4~20mA/0~10V, AO3: 4~20mA, 可規劃成對應設定/實際輸出頻率/輸出電流/輸出電壓, 頻率指令或電動機轉速...等計 15 種功能, 增益及偏壓可由使用者任意自定及配合監控功能提供信號輸出。[可擴充至 3 組]		
	異常/故障信號輸出 [26]	可規劃至 2 個 "C" 接點的繼電器(電氣壽命 30 萬次)或 2[4]個開集極輸出。		
通訊功能 [27]	RS-485 通訊埠, Modbus ASCII & RTU, 傳輸速率可達 125 kbps。[RS-232, RS-488, CANopen, Device Net, Profibus, USB]			
系統內建功能 [28]	可調的PID回授控制, P/PI 切換功能, 回授信號異常偵測, 電源瞬停再啟動, 自動穩壓輸出-AVR, S曲線及自動最佳化加/減速時間, 外部異常聯鎖/重置, 30次異常自動復歸/手動復歸再啟動, 自動高效率節能運轉, 可設定減額運轉, 輸出頻率上/下限, 偏置頻率, 密碼鎖定, 多風機/水泵程序交替/睡眠/甦醒控制/自動定壓運轉功能, 兩組電動機參數且自動調適, By-Pass 商用電源切換, Y-Δ 運轉中切換, RS-485 斷線偵測, 雙向自動速度追蹤, 飛輪啟動, 轉向限制, 16段速運轉, 減速/滑行停止, 機械煞車聯鎖控制, 預警功能, 靜音運轉模式, 遠方/現場/自動/手動/通訊無縫切換, 使用者自定多功能顯示內容, 啟動/運轉電流的高低限制, 轉矩控制/限制, Sink/Source(NPN/PNP)模式選擇, 內部計數器, 齒隙暫停, 擺擺功能, 減速時電壓偏移, 可控式散熱風扇(連續/節能), 16段PLC Run, 兩套參數可切換, 五種多重參數群組設定功能。[定時運轉/停止, 內置EMC/零相濾波器, AC/DC電抗器, 12/18脈波整流, 控制系統之獨立電源板, 可由外加電池組供電及並接DC BUS, PG回授閉迴路速度控制]			
保護功能 [29]	電源及訊號之: Soft Start/突波/雷擊, 過電壓/低電壓/瞬間停電/欠相/不平衡/相對地過電流, 相位指示; DC-Bus 之: 過電壓/低電壓/短路 加速中/定速中/減速中之: 過電壓/過電流, 過負載, 過轉矩, 過電流及過電壓失速防止, IGBT 模組之短路/過熱, 散熱器過熱, 散熱風扇異常, 電子式熱動電驛, 輸出側短路/接地, 保險絲熔斷保護, 可調的過電流跳脫, 輸出 dv/dt 電壓抑制功能。 電動機之: 過電流/欠相/欠載/過載/過熱/失速/低速/超速/短路, 溫昇預警 系統之: 自我診斷, PWM 切換錯誤, 軟體錯誤, 外部異常中斷, Dry Pump, Broken Belt 及 Bump-less 功能, 濾波電容及冷卻風扇老化監視及預警功能, 可依 IGBT 模組溫度自動調節 PWM 載波頻率, 可顯示及無電永久保存 程式/參數/16/[48]次異常記錄及每筆異常時的運轉資訊如: 異常原因, DC-Bus 電壓, 輸出電壓/頻率/電流, 頻率指令, IGBT 溫度及散熱器溫度[日期, 時間, 功率, 轉矩, 運轉狀態, 濾波電容過熱]等。			
操作及顯示 [30]	8 個薄膜按鍵: 可執行 運轉, 停止, 重置, 正轉/反轉, 顯示頁面切換, 數位左移, 參數資料設定, 快捷功能, 鍵盤/外部運轉及寸動運轉... 等			
	1 個 360 度編碼器式飛梭旋鈕: 可設定頻率, 瀏覽, 修改, 比較, 設定參數及作參數值輸入限定亦可配合智慧型多功能輸出端子動作... 等 1 個 6 位數的 7 節 LED 顯示器: 可顯示設定頻率, 實際輸出頻率, 電壓, 輸出電流, 電動機轉向, 電動機轉速, 各種異常故障顯示, 使用者自定義多功能顯示內容(如輸入/輸出之電流, 電壓, 功率, 容量, 溫度, 時間...計 88 種) 6 個狀態指示 LED 燈: 可分別顯示變頻器的運轉狀態, 運轉/停止, 正轉/反轉, 鍵盤運轉指令/外部運轉指令等 1 個 RJ-45 插座: 操作器可分離, 可熱插拔, 遠程遙控距離可達 150 公尺以上, 已配置 PU-01 操作器如上功能。[PU-02 俱複製, 儲存, 比對功能] [PU-03 俱複製, 儲存, 比對功能及 LCD 中英文及圖形可同時顯示 7 種運轉資訊, 如電壓, 電流, 頻率, 轉速, 轉向, 命令值, 輸出值, 溫度...等]			
機構與環境	安規認證及抗干擾等級 [31]	符合 CE, cUL 及 UL508C 之規範; 符合歐盟 RoHS 指令, 內置基本型射頻干擾(RFI)雜訊抑制濾波器已符合 EMC: EN61800-3 (EN61800-4-2 ~ EN61800-4-6)之規範, 加配本公司特定濾波器時符合 EN 55011, Class A/B 規範,		
	箱體構造 [32]	A, B 及 C 框號機種--壁掛式低阻度強化塑膠及金屬包覆 EMC 防護殼體, D, E, F 及 G 框號機種--壁掛式鍍鋅鋼板烤漆金屬屏蔽包覆 EMC 防護殼體, 全部控制配線與動力配線均實行電氣隔離保護及獨立接線區塊設計。		
	溫度及濕度 [33]	操作環境: -10℃ ~ +40℃ [-10℃ ~ +50℃]; 儲存環境: -20℃ ~ +65℃, 濕度: 98% R.H. 以下, 無結露。		
	安裝場所及高度 [34]	室內適用, 無腐蝕性氣體, 液體及粉塵, 海拔 1000m 以下, 振動: 0.5G 以下, 符合 IEC60068-2/6/27 及 -2-34/35/36		

*TOPVERT 全系列產品均依 CNS, IEC, IEEE, NEMA, ANSI, NEC, JIS, DIN, CE, CSA, UL 及 cUL 之規範設計製造, 台灣地區販售之產品均在台灣製造。[]: 選配功能

機種規格

TOPVERT G1 及 H1 系列:單相電源, 200/-15% ~ 240/+10% VAC, 47 ~ 63Hz /[400Hz]											
型號	適用電動機(230V 4P)		額定輸出				電源	箱體結構			
TOPVERT G1-xxxxx H1-xxxxx	功率 (kW)	馬力 (Hp)	容量 (kVA)	電流 (A)	電壓 (V)	頻率 (Hz)	電流 (Amax.)	冷卻方式 運轉噪音	保護等級	淨重 (kg)	外型框號
210P4	0.4	0.5	1.2	3	3 相, 0 ~ 額定 電源電 壓	G1 系列: 0 ~ 600 H1 系列: 0 ~ 6000	5.7	強制風冷 <70 dB/1M	IP 20 NEMA 1 [IP 21/40/42 /50/52 可加裝]	2.6	G1-A H1-A
210P7	0.75	1	2	5			9.5			2.7	
211P5	1.5	2	3	7.5			14			2.7	
212P2	2.2	3	4.4	11			21			3.0	

TOPVERT G1 及 H1 系列:三相電源, 200/-15% ~ 240/+10% VAC, 47 ~ 63Hz /[400Hz]											
型號	適用電動機(230V 4P)		額定輸出				電源	箱體結構			
TOPVERT G1-xxxxx H1-xxxxx	功率 (kW)	馬力 (Hp)	容量 (kVA)	電流 (A)	電壓 (V)	頻率 (Hz)	電流 (Amax.)	冷卻方式 運轉噪音	保護等級	淨重 (kg)	外型框號
230P4	0.4	0.5	1.2	3	∞ 相 0 ~ 額定 電源電 壓	G1 系列: 0 ~ 600 H1 系列: 0 ~ 6000	3.3	強制風冷 <70 dB/1M	IP 20 NEMA 1 [IP 21/40/42 /50/52 可加裝]	2.6	G1-A H1-A
230P7	0.75	1	2	5			5.5			2.8	
231P5	1.5	2	3	7.5			8.3			2.8	
232P2	2.2	3	4.4	11			12			2.8	
233P7	3.7	5	6.8	17			19			3.0	
235P5	5.5	7.5	10	25			28			3.2	
237P5	7.5	10	13	33			36			4.0	
23011	11	15	20	49			54			11.9	
23015	15	20	26	65			72			12.3	
23018	18.5	25	30	75			83			13.0	
23022	22	30	36	90			99		13.5		
23030	30	40	48	120			132		32.7		
23037	37	50	58	145			160		33.8		
23045	45	60	73	182			200		34.6		
23055	55	75	92	232			255		58.0		
23075	75	100	120	300			330		59.4		
23090	90	125	143	360			396		192		
23110	110	150	175	440			484		192		
23132	132	175	207	520			572		198		
23132S	132	175	207	520			572		572	302	[IP 21/40/42 /50/52 NEMA 1 可加裝]

[]: 選配之功能

TOPVERT G1 及 H1 系列:三相電源 380/-15% ~ 480/+10% VAC, 47 ~ 63Hz /[400Hz]											
型號	適用電動機 (4 pole)		額定輸出				電源	箱體結構			
TOPVERT G1-xxxxx H1-xxxxx	380/415 V (kW/HP)	440/460 V (kW/HP)	容量 (kVA)	電流 (A)	電壓 (V)	頻率 (Hz)	電流 (Amax.)	冷卻方式 運轉噪音	保護等級	淨重 (kg)	外型框號
430P7	0.75/1		2.4	3	∞ 相 0 ~ 額定 電源電 壓	G1 系列: 0 ~ 600 H1 系列:	3.3	強制風冷 <70 dB/1M	IP 20 NEMA 1 [IP 21/40/42 /50/52]	2.8	G1-A H1-A
431P5	1.5/2		3.3	4.2			4.6			2.9	
432P2	2.2/3		4.8	6			6.6			2.9	
433P7	3.7/5		6.8	8.5			9.4			2.9	
435P5	5.5/7.5		10	13			14			3.0	
437P5	7.5/10		14	18			20			3.3	

43011	11/15		19	24	0 ~ 6000	26	可加裝]	4.3	G1-B			
43015	15/20		25	32		35		5.0	H1-B			
43018	18.5/25		32	40		44		13.0	G1-C H1-C			
43022	22/30		38	48		53		13.0				
43030	30/40		48	60		66		13.9				
43037	37/50		64	80		88		13.9				
43045	45/60		77	97		107		13.9	G1-D H1-D			
43055	55/75	75/100	94	118		130		33.5				
43075	75/100	90/125	121	152		167		37.1	G1-E H1-E			
43090	90/125	110/150	143	180		198		42.4				
43110	110/150	132/175	191	240		264		63.0	G1-F H1-E			
43132	132/175	160/215	215	270		297		64.5				
43160	160/215	185/250	242	304		334		64.5	G1-G			
43185	185/250	220/300	295	370		407		192				
43220	220/300	280/375	359	450		495		192				
43280	280/375	315/422	414	520		572		198				
43315	315/422	375/500	486	610		671		198	G1-H 立櫃型			
43280S	280/375	315/422	414	520		572		302				
43315S	315/422	375/500	486	610		671		312				
43400S	400/535	450/600	583	732		805		333				
43450S	450/600	500/670	690	866		953		341				
43500S	500/670	560/750	766	962		1058		348				
43560S	560/750	630/850	872	1094		1203		355				
43630S	630/850	750/1000	966	1212		1333		360				
						強制風冷		IP 20 NEMA 1		302	G1-H 立櫃型	
						<80 dB/1M		[IP 21/40/42 /50/52 NEMA 1 可加裝]		312		
								[IP 21/40/42 /50/52 可加裝]	333			
									341			
								348				
								355				
								360				

TOPVERT P1 系列 : 三相電源, 200/-15% ~ 240/+10% VAC, 47 ~ 63Hz / [400Hz]											
型號	適用電動機 (230V 4 P)		額定輸出				電源	箱體結構			
	功率 (kW)	馬力 (Hp)	容量 (kVA)	電流 (A)	電壓 (V)	頻率 (Hz)		電流 (Amax.)	冷卻方式 運轉噪音	保護等級	淨重 (kg)
TOPVERT P1-xxxxx					∞ 相 0 額定 電源 電壓	0 ~ 600	4	強制風冷 <70 dB/1 M	IP 20 NEMA 1	2.6	P1-A
230P7	0.75	1	1.4	3.6			6.6			2.8	
231P5	1.5	2	2.4	6			9.9			2.8	
232P2	2.2	3	3.6	9			15			2.8	
233P7	3.7	5	5.3	13.2			22		3.0		
235P5	5.5	7.5	8.1	20.4			33		3.2		
237P5	7.5	10	12	30			44		4.0		
23011	11	15	16	39.6			65		11.9		
23015	15	20	23	58.8			86		12.3		
23018	18.5	25	31	75			99		13.0		
23022	22	30	36	90			119		13.5		
23030	30	40	43	108			158		IP 00 NEMA 0		
23037	37	50	57	144			191			32.7	
23045	45	60	69	174			240			33.8	
23055	55	75	87	218.4			306			34.6	
23075	75	100	111	278.4			396		58.0		
23090	90	125	143	360			475		59.4		
23110	110	150	172	432			581		192		
23132	132	175	210	520					192		

[]: 選配之功能

TOPVERT P1 系列 : 三相電源, 三相電源 380/-15% ~ 480/+10% VAC, 47 ~ 63Hz / [400Hz]														
型號	適用電動機 (4 pole)		額定輸出				電源	箱體結構						
TOPVERT P1-xxxxx	380/415 V (kW/Hp)	440/460 V (kW/Hp)	容量 (kVA)	電流 (A)	電壓 (V)	頻率 (Hz)	電流 (Amax.)	冷卻方式 運轉噪音	保護構造 (IP/NEMA)	淨重 (kg)	外型框號			
431P5	1.5/2		2.9	3.6	ω 相 額定電源電壓	0 ~ 600	4	強制風冷 <70 dB/1 M	IP 20 NEMA 1	2.8	P1-A			
432P2	2.2/3		4	5.04			5.5			2.9				
433P7	3.7/5		5.7	7.2			7.9			2.9				
435P5	5.5/7.5		8.1	10.2			11			2.9				
437P5	7.5/10		12	15.6			17			3.0				
43011	11/15		17	21.6			24			3.3				
43015	15/20		23	28.8			32		4.3	[IP 21/40/42 /50/52 可加裝]	5.0	P1-B		
43018	18.5/25		31	38.4			42		13.0					
43022	22/30		38	48			53		13.0					
43030	30/40		46	57.6			63		13.9	P1-C				
43037	37/50		57	72			79		13.9					
43045	45/60		76	96			106		13.9					
43055	55/75		93	116.4			128		33.5	IP 00 NEMA 0	37.1	P1-D		
43075	75/100	90/125	113	141.6			156		42.4		[IP 21/40/42 /50/52 NEMA 1 可加裝]		63.0	P1-E
43090	90/125	110/150	145	180			201		64.5				P1-F	
43110	110/150	132/175	172	216			238	64.5						
43132	132/175	160/215	229	270			317	192	P1-G					
43160	160/215	185/250	258	304			356	192						
43185	185/250	220/300	291	365			401	198						
43220	220/300	280/375	354	444			488	198	強制風冷 <80 dB/1 M	IP 20 NEMA 1 [IP 21/40/42 /50/52 可加裝]	P1-H 立櫃型			
43280	280/375	315/422	430	520			594	312						
43315	315/422	375/500	497	610			671	333						
43400	400/535	450/600	583	732			805	341	P1-H 立櫃型					
43315S	315/422	375/500	497	610			671	348						
43400S	400/535	450/600	583	732			805	355						
43450S	450/600	500/670	700	866			953	360						
43500S	500/670	560/750	828	962			1058							
43560S	560/750	630/850	920	1094			1203							
43630S	630/850	750/1000	1046	1212			1333							

[]: 選配之功能

基本配線圖

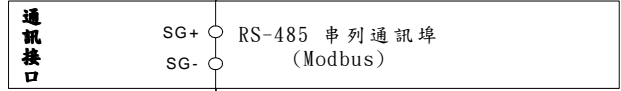
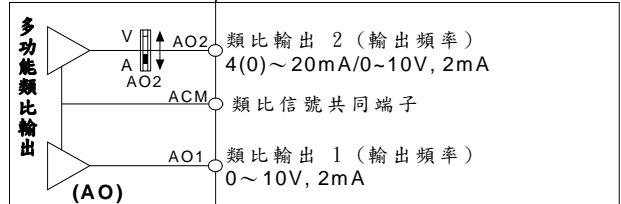
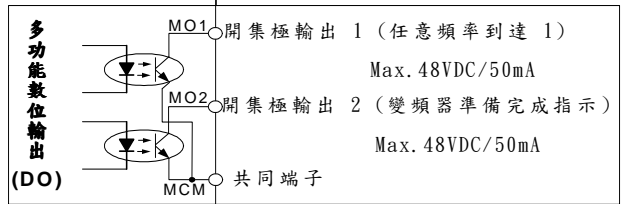
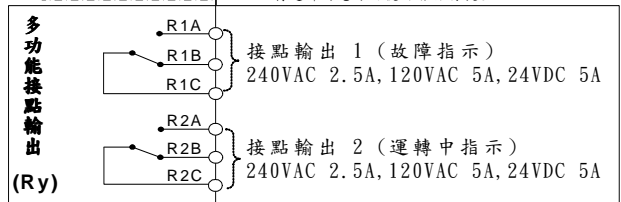
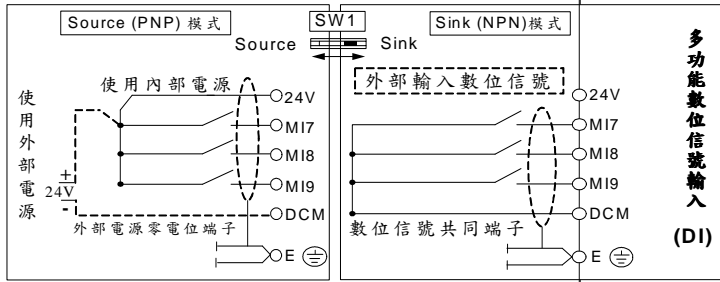
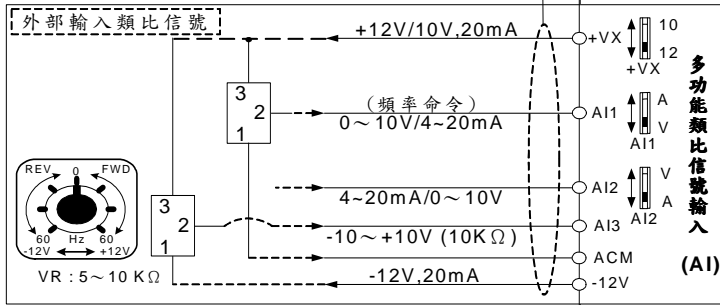
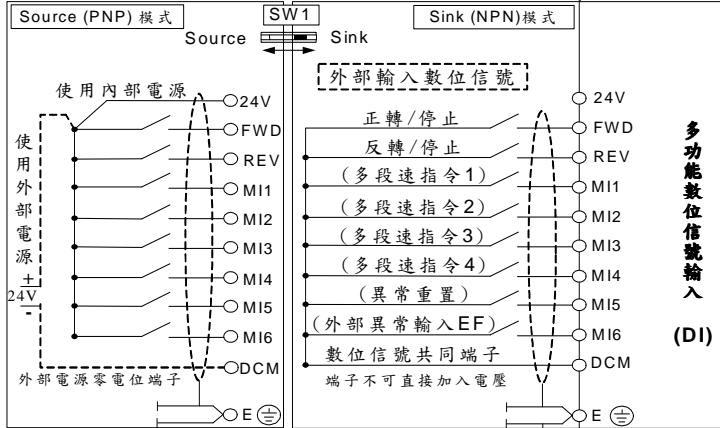
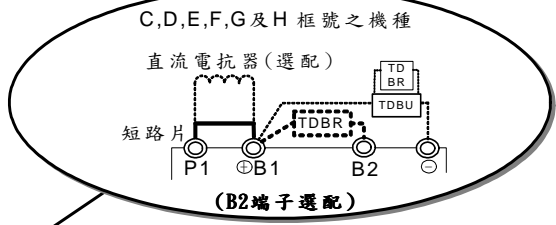
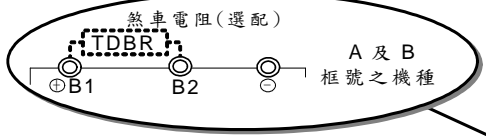
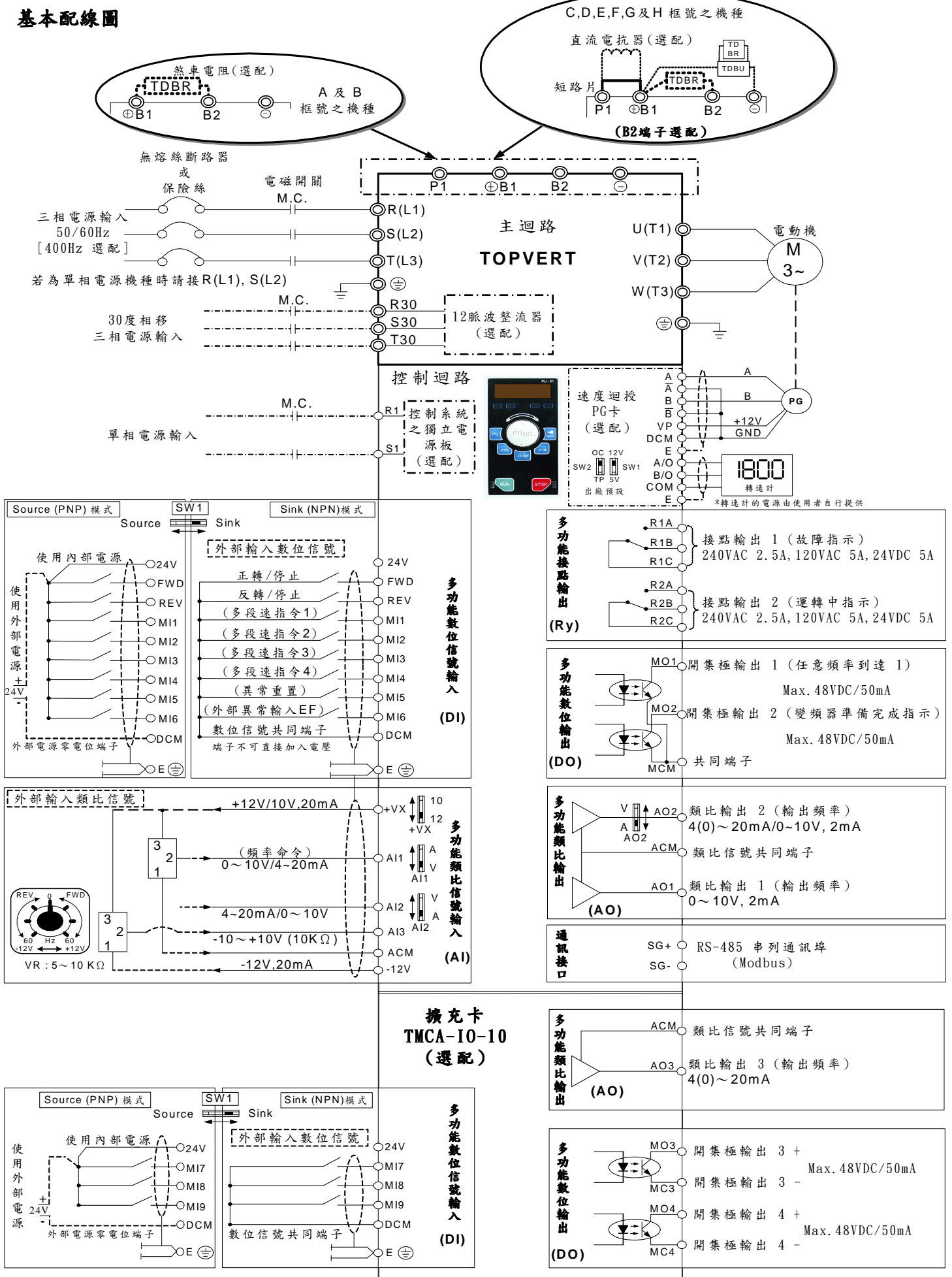

擴充卡 TMCA-IO-10 (選配)

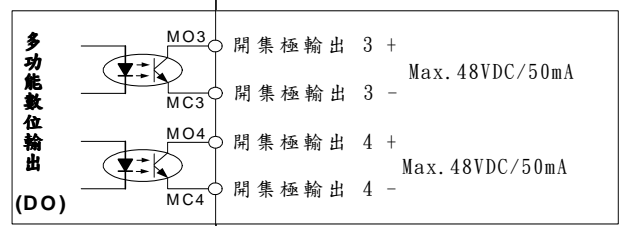
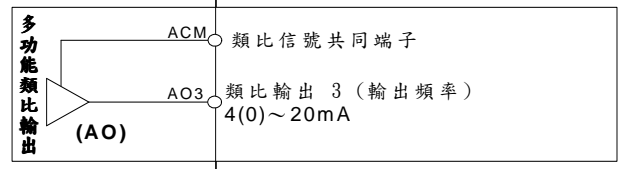

附註：◎ → 主迴路 ○ → 控制迴路 ⊗ → 具有被覆隔離網之隔離紋線 () → 出廠預設功能 □ → 選配

主迴路端子說明

端子符號	內容說明
R(L1), S(L2), T(L3)	主電源輸入端子, 接至商用電源。 供應電源之電壓及容量應符合所安裝之變頻器所需。
R30, S30, T30 (選配)	30度相移三相電源輸入端子, 接至二次繞組俱雙Star-Delta之三相電源變壓器。供應電源之電壓及容量應符合所安裝之變頻器所需。
R1, S1 (選配)	控制系統之獨立電源輸入端子, 電壓規格同主電源; 此端子可單獨供電或與主電源輸入端子同時供電, 但若僅此端子單獨供電時變頻器不能運轉, 僅能查詢記錄, 檢查控制信號, 參數設定, 或故障排除等動作。
U(T1), V(T2), W(T3)	變頻器輸出端子, 接至三相感應電動機。
⊕/B1, B2	外接煞車電阻連接端子, 請依使用手冊第九章選用安裝。
⊕/B1, ⊖	外接動態煞車器連接端子。(直流電源輸入接續端子)
P1, ⊕/B1	直流電抗器連接端子, 安裝時請將短路片拆除。
	接地端子, 共有二個, 必需依電工法規: G1-430V機種採第三種接地, 460V/575V機種採特種接地。靠近電源端子的一個用於接至電源系統的真大地; 靠近輸出端子的一個用於接至電動機的外殼。

控制迴路端子標示說明

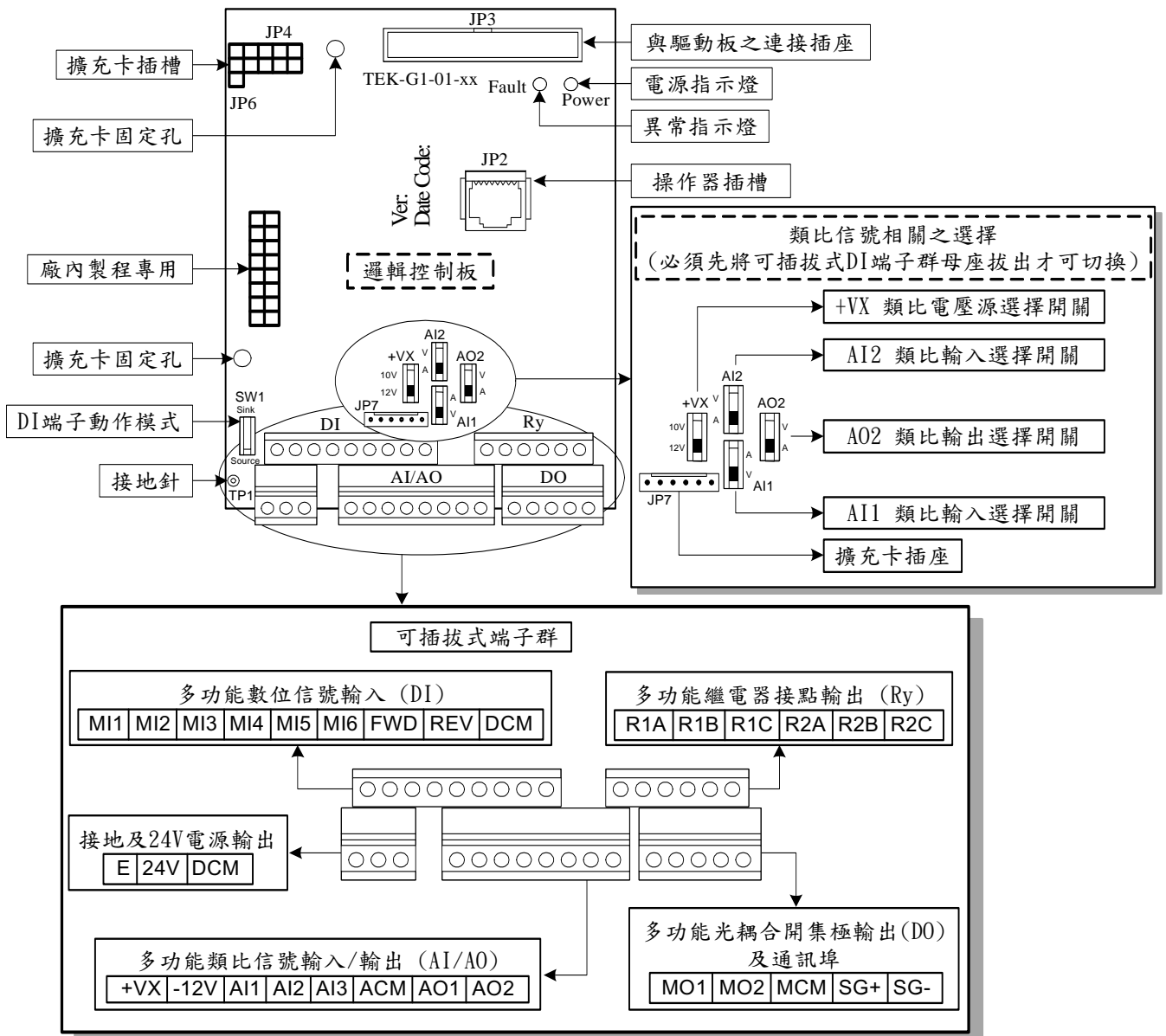

控制迴路端子說明

端子符號	端子功能說明	額定限制/對應參數位址 (出廠預設定功能)
數位信號輸入相關 (建議採用18 AWG (0.75 mm ²) 有遮蔽對絞線配線)		
MI1	多功能數位輸入端子 1 (三線式STOP指定端子)	Pr2-01/(多段速一命令)
MI2	多功能數位輸入端子 2	Pr2-02/(多段速二命令)
MI3	多功能數位輸入端子 3	Pr2-03/(多段速三命令)
MI4	多功能數位輸入端子 4	Pr2-04/(多段速四命令)
MI5	多功能數位輸入端子 5	Pr2-05/(異常重置命令)
MI6	多功能數位輸入端子 6 (TRG指定端子)	Pr2-06/ (EF)
FWD	正轉運轉/停止 命令	Pr2-00/(正轉運轉/停止)
REV	反轉運轉/停止 命令	Pr2-00/(反轉運轉/停止)
DCM	數位輸入信號的參考點，24V電源端子的參考點，此端子與ACM端子成絕緣關係。	共有2個，功能相同
[MI7]	[多功能數位輸入端子 7]	Pr2-26
[MI8]	[多功能數位輸入端子 8]	Pr2-27
[MI9]	[多功能數位輸入端子 9]	Pr2-28
繼電器接點輸出相關 (必須與其它所有的控制迴路端子分離配線)		
R1A	多功能輸出 1 (繼電器乾接點輸出)	Pr2-20, Pr2-21 電阻性負載 5A(N.O.)/3A(N.C.) 240VAC/24VDC 電感性負載 1.5A(N.O.)/0.5A(N.C.) 240VAC/24VDC
R1B	R1A-R1C :Relay 1 常開 (a接點)	
R1C	R1B-R1C :Relay 1 常閉 (b接點)	
R2A	多功能輸出 2 (繼電器乾接點輸出)	
R2B	R2A-R1C :Relay 2 常開 (a接點)	
R2C	R2B-R1C :Relay 2 常閉 (b接點)	
數位信號控制電源 及 接地端子 (建議採用18 AWG (0.75 mm ²)有遮蔽對絞線配線)		
E	數位及類比訊號隔離線，外層披覆隔離網連接用的接地端子。	
24V	數位信號共用電源端子，參考點為 DCM。	Max. 50mA
DCM	數位輸入信號的參考點。24V電源端子的參考點，此端子與ACM端子成絕緣關係。	共有2個，功能相同
類比信號輸入輸出相關 (建議採用18 AWG (0.75 mm ²)有遮蔽對絞線配線)		
微弱的類比信號，特別容易受外部雜訊干擾影響，所以配線應盡可能短(小於20m)，遮蔽對絞線的外圍網線基本上應接地(E端子)，但若現場的誘導雜訊大時，連接到ACM端子的效果反而會較好。如需在此電路中使用接點，則應使用能處理弱信號的雙叉接點，但ACM端子不要使用接點控制。		
+VX	+12V/+10V可切換的類比電壓源，參考點為ACM。	Max. 20mA/(+12V)
-12V	-12V 類比電壓源，參考點為ACM。	Max. 20mA
AI1	多功能類比輸入 1 (可選擇輸入電壓或電流信號) (當AI1 類比信號輸入選擇開關選擇"V"時，可接入DC 0~10V 電壓信號；選擇"A"時，可接入DC 4(0)~20mA 電流信號)	Pr3-02/(DC 0~10V對應頻率命令)
AI2	多功能類比輸入 2 (可選擇輸入電流或電壓信號) (當AI2 類比信號輸入選擇開關選擇"V"時，可接入DC 0~10V 電壓信號；選擇"A"，可接入DC 4(0)~20mA 電流信號)	Pr3-06/(4~20mA對應頻率命令)
AI3	多功能類比輸入 3 (可輸入DC -10~+10V 電壓信號)	Pr3-11/(DC -10~+10V對應頻率命令)

ACM	類比輸入與輸出信號的參考點,此端子與DCM端子成絕緣關係。	
A01	多功能類比輸出 1 (可輸出DC 0~10V 電壓信號)	Max. 2mA/Pr3-15/(對應輸出頻率)
A02	多功能類比輸出 2 (可選擇輸出電流或電壓信號) (當A02 類比信號輸出選擇開關選擇”V”時,可輸出DC 0~10V 電壓信號;選擇”A”時,可輸出DC 4(0)~20mA 電流信號)	Pr3-16/(4~20mA 對應輸出頻率)
[A03]	[多功能類比輸出 3] (可輸出4(0)~20mA 電流信號)	Pr3-15/(4~20mA 對應輸出頻率)
數位信號輸出及通訊埠 相關 (建議採用18 AWG (0.75 mm ² 有遮蔽對絞線配線)		
MO1	多功能輸出 3 (光耦合開集極輸出端子 1)	Max. 48VDC, 50mA/(速度到達 1)
MO2	多功能輸出 4 (光耦合開集極輸出端子 2)	Max. 48VDC, 50mA/(變頻器準備完成)
MCM	多功能數位輸出3及4 光耦合開集極輸出端子共同端	
SG+	RS-485 串列通訊埠的连接端子 +	應選用有遮蔽對絞線连接
SG-	RS-485 串列通訊埠的连接端子 -	
[MO3]	[多功能數位輸出 5 - 開集極輸出端子MO 3+]	Pr2-24
[MC3]	[多功能數位輸出 5 - 開集極輸出端子MO 3-]	
[MO4]	[多功能數位輸出 6 - 開集極輸出端子MO 4+]	Pr2-25
[MC4]	[多功能數位輸出 6 - 開集極輸出端子MO 4-]	

[] :需選配擴充卡才有此功能

數位操作器各部位功能說明

陽岡科技率先採用了360度編碼器式飛梭旋鈕,使得參數的設定變的快速方便,也突破了傳統可變電阻(VR)式旋鈕解析度低的缺點,從數位操作器以飛梭旋鈕設定輸出頻率解析度可高達0.01Hz.

PU-01 數位操作器各部位功能說明

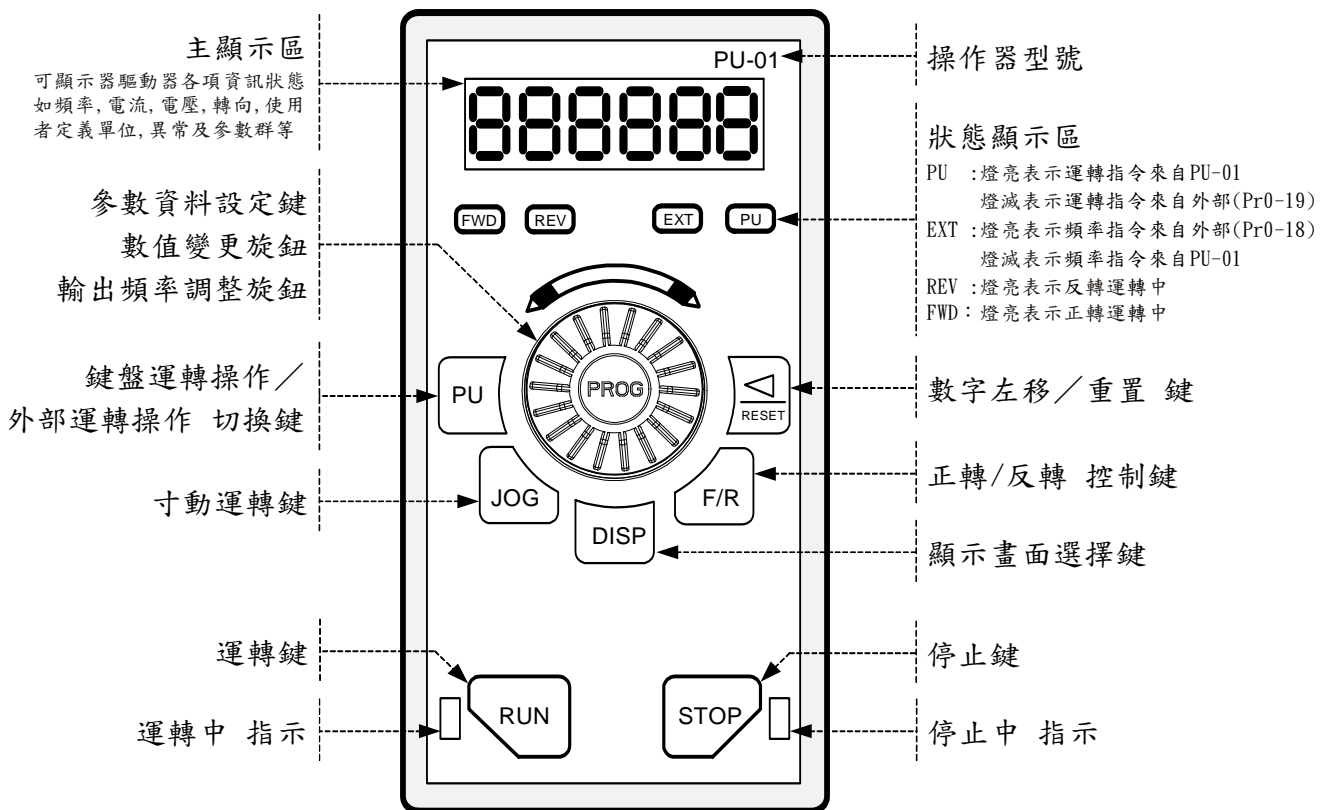

PU-02 數位操作器各部位功能說明(選配)

保有 PU-01 全部功能, 還俱備了參數 讀出/寫入/儲存/複製功能, 並可儲存二組用戶參數組

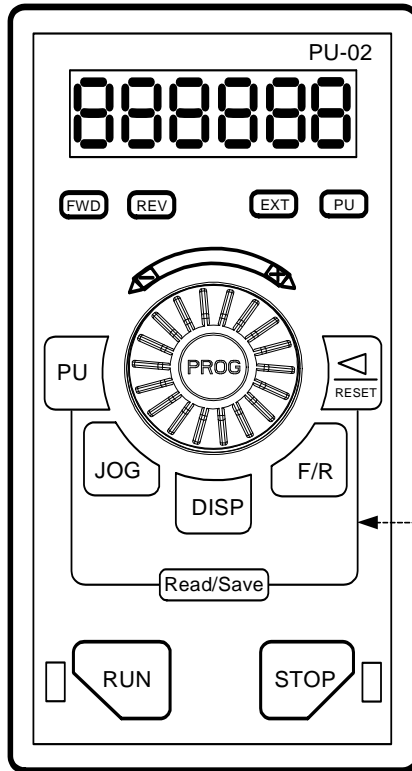

同時按下PU及RESET鍵
可執行Read(讀出)及
Save(寫入)的功能

PU-03 數位操作器各部位功能說明(選配)

保有 PU-01 全部功能, 還俱可由使用者規劃的LCD中英文顯示

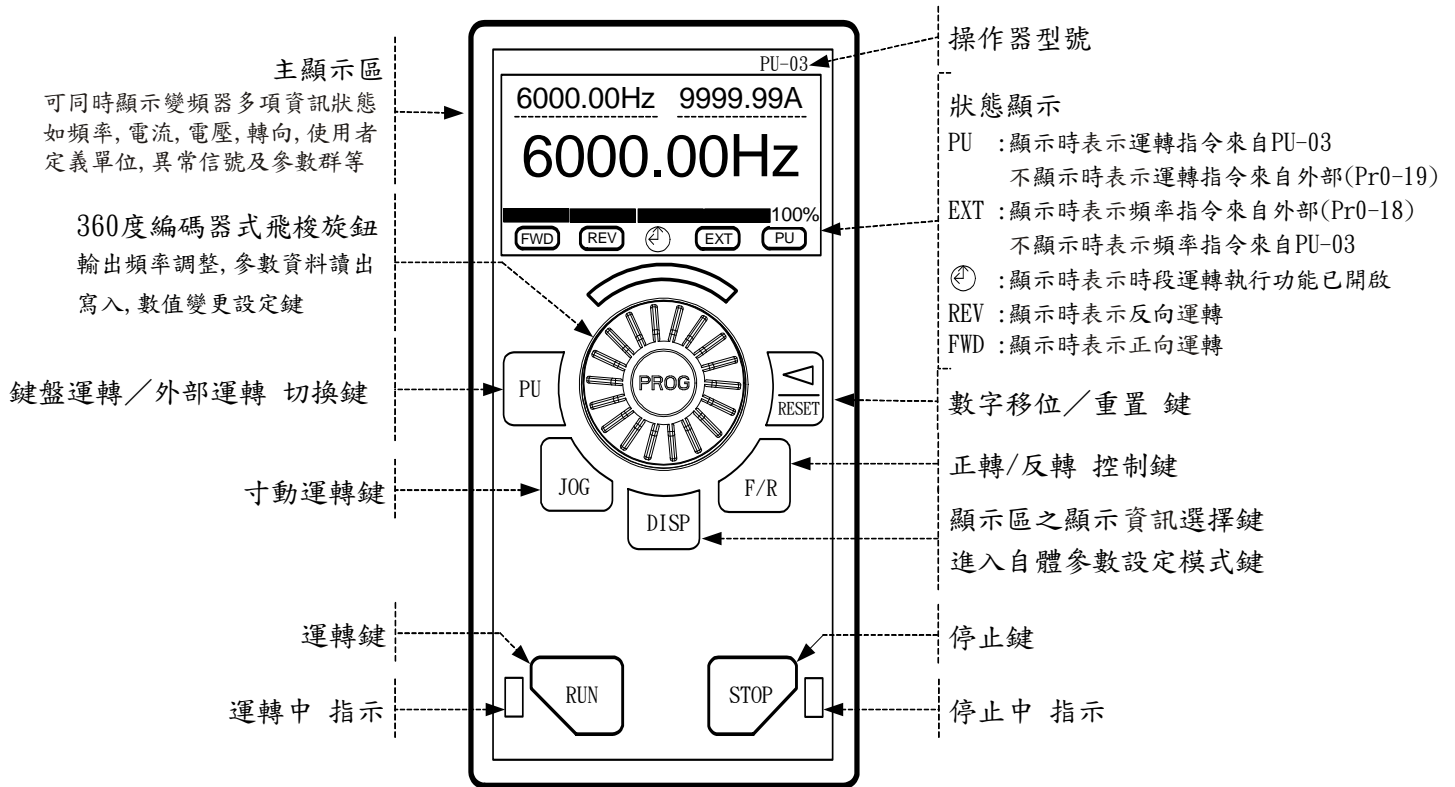

主顯示區
可同時顯示變頻器多項資訊狀態
如頻率, 電流, 電壓, 轉向, 使用者
定義單位, 異常信號及參數群等

360度編碼器式飛梭旋鈕
輸出頻率調整, 參數資料讀出
寫入, 數值變更設定鍵

鍵盤運轉/外部運轉 切換鍵

寸動運轉鍵

運轉鍵

運轉中 指示

操作器型號

狀態顯示

PU : 顯示時表示運轉指令來自PU-03
不顯示時表示運轉指令來自外部(Pr0-19)

EXT : 顯示時表示頻率指令來自外部(Pr0-18)
不顯示時表示頻率指令來自PU-03

🕒 : 顯示時表示時段運轉執行功能已開啟

REV : 顯示時表示反向運轉

FWD : 顯示時表示正向運轉

數字移位/重置 鍵

正轉/反轉 控制鍵

顯示區之顯示資訊選擇鍵
進入自體參數設定模式鍵

停止鍵

停止中 指示

顯示功能說明

顯示項目	說明
	'F' 顯示變頻器目前的設定頻率 (可按 DISP 鍵觀看)
	'H' 顯示變頻器實際輸出到電動機的頻率 (可按 DISP 鍵觀看)
	'A' 顯示負載電流 (可按 DISP 鍵觀看)
	'u' 顯示用戶在多功能顯示選擇(Pr0-07)所選擇的內容 (可按 DISP 鍵觀看)
	顯示Read/Save的選擇內容 (只適用於PU-02) (可按 DISP 鍵觀看)
	選擇參數位址 (可“按下”與“旋轉”  飛梭旋鈕來選擇參數位址) (按下  鍵可依序顯示已更改過的參數位址)
	顯示參數內容值 (可“按下”與“旋轉”  飛梭旋鈕來設定參數內容值)
	表示資料已被接受並存入內部記憶體 (參數設定完成後按一下  旋鈕來完成資料存入內部記憶體並顯示End)

操作功能說明

1. 顯示訊息的操作

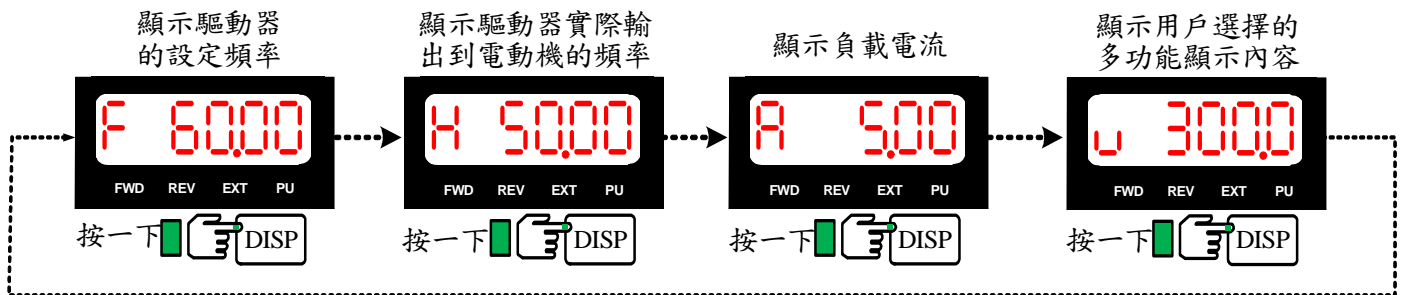

每按一下” DISP” 鍵，顯示器可在F頁面、H頁面、A頁面及U面切換

2. 參數設定的操作 (以將Pr0-07設定成2 為例)

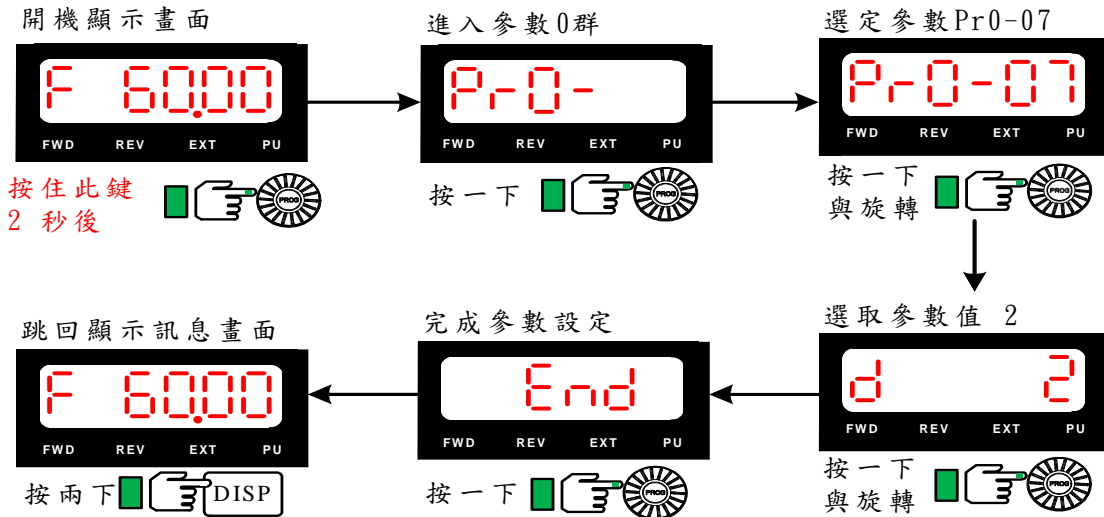

3. 運轉的操作 (以從PU執行以50Hz運轉為例)

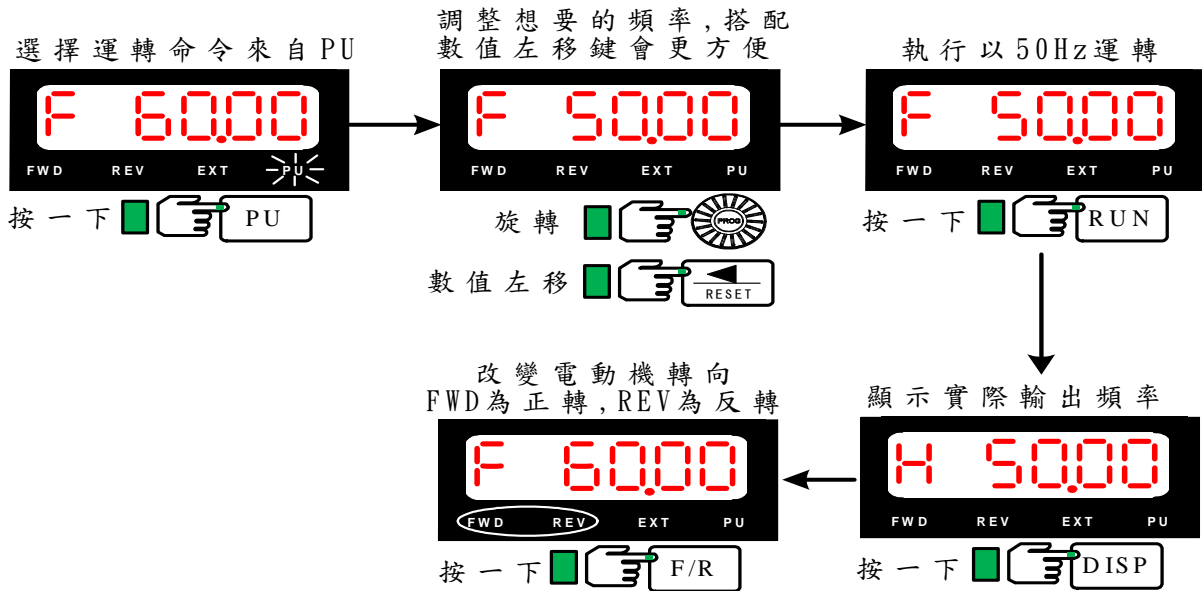

4. 參數讀出/寫入(Read/Save)的操作 (只適用於 PU-02)(參數複製僅限於在同樣機型間執行)

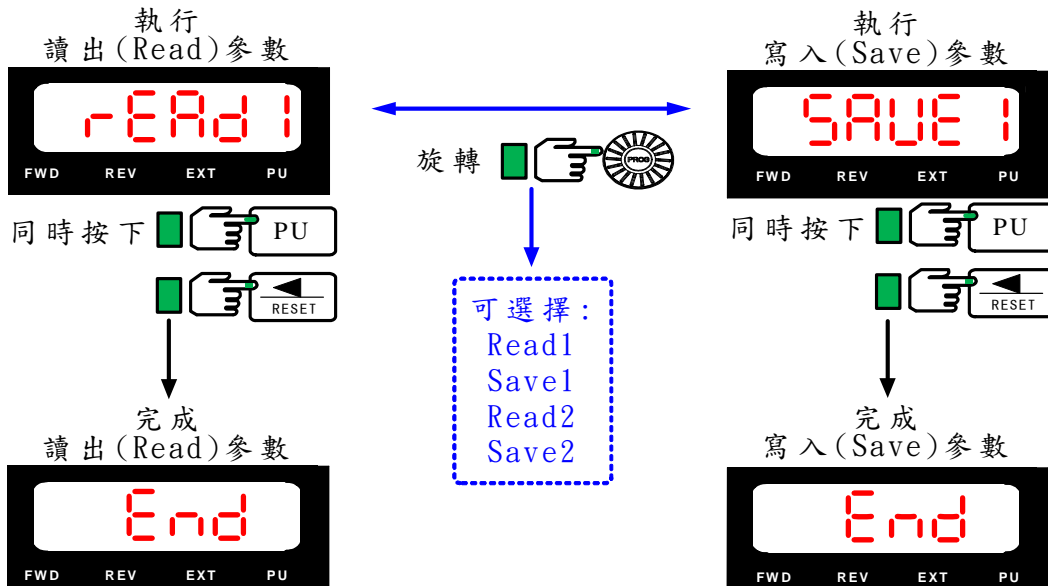

功能・參數一覽表

0 參數群：系統參數

★=運轉中不可設定 ◎:僅適用於軟體版本:2.xx以後之產品 []內為1.xx 軟體版本原參數編號

參數	參數功能	設定範圍	出廠值	客戶
★ Pr0-00	機型顯示	依機型顯示,僅能讀取	唯讀	
★ Pr0-01	額定輸出電流	依機型顯示,僅能讀取	唯讀	
★ Pr0-02	參數重置 (電動機規格選擇)	10: 參數重置成為符合 60Hz - 230/460/575V 之電動機的環境	8	
		9: 參數重置成為符合 50Hz - 220/380/575V 之電動機的環境		
		8: 參數重置成為符合 60Hz - 220/380/575V 之電動機的環境		
		7: 參數重置成為符合 50Hz - 230/460/575V 之電動機的環境		
		6: 參數重置成為符合 60Hz - 240/415/575V 之電動機的環境		
		5: 參數重置成為符合 50Hz - 240/415/575V 之電動機的環境		
Pr0-03	參數保護密碼輸入 (鑰匙)	0~9999	0	
Pr0-04	參數保護密碼設定 (鎖頭)	0~9999	0	
Pr0-05	參數保護等級	Bit 0 (bxxxx0)	b00000	
		Bit 1 (bxxx0x)		
		Bit 2 (bxx0xx)		
		0: 所有參數皆可讀取 1: Pr0-05 之後的參數不可讀取。 (嘗試讀取會顯示"Err")		
Pr0-06	開機預設顯示頁面	0: 顯示 頻率命令值 (F)	0	
		1: 顯示 實際輸出頻率(H)		
		2: 顯示 輸出電流(A)		
		3: 顯示 使用者於 Pr0-07 所定義的顯示內容		
Pr0-07	定義多功能顯示內容	0: 電動機轉速 (RPM)	0	
		1: DC-Bus 電壓 (Vdc)		
		2: 實際輸出電壓 (Vac)		
		3: 輸出電壓命令值(Vac)		
		4: PID 回授頻率值 (Hz)		
		5: 多段速運轉執行中之段數		
		6: 睡眠時間 (Pr8-07)		
		7: 異常再啟動次數(Pr6-10)		
		8: PID 命令值 (Hz)		
		9: (廠內保留)		
		10: 輸出功率因數 (°)		
		11: 計數器計數值		
		12: 過轉矩檢出時間 1 (Pr5-17)		
		13: (廠內保留)		
		14: 加速時齒隙暫停時間(Pr6-14)		
		15: 減速時齒隙暫停時間 (Pr6-16)		
		16: 啟動時直流制動時間(Pr6-01)		
		17: 停車時直流制動時間(Pr6-02)		
		18: 多段速運轉執行中未完時間		
		19: (廠內保留)		
		20: (廠內保留)		
		21: 累積上電的天數 (Day)		
		22: 累積上電的時間 (hh:mm)		
		23: (廠內保留)		
		24: (廠內保留)		
		25: (廠內保留)		
26: AI1輸入端對應的比例值 出廠值範圍: 0~10				

			27: AI2輸入端對應的比例值 出廠值範圍: 0~10																											
			28: AI3輸入端對應的比例值 REV<~-10V~ 0 ~10V~>FWD 出廠值範圍: 0~10																											
			29: (廠內保留)																											
			30: (廠內保留)																											
			31: (廠內保留)																											
			32: (廠內保留)																											
			33: (廠內保留)																											
			34: 過轉矩檢出準位 1 (Pr5-16)																											
			35: 電動機 1 轉矩補償(Pr5-01)																											
			36: (廠內保留)																											
			37: (廠內保留)																											
			38: 恆定轉矩輸出區恆速運轉中過電流失速防止準位 (Pr5-12)																											
			39~ 52: (廠內保留)																											
			53: 輸出功率 (kW)																											
			54: 輸出容量 (kVA)																											
			55: (廠內保留)																											
			56: IGBT 模組或散熱器溫度-TH1(°C)																											
			57: 變頻器週溫-TH2 (°C)																											
			58~59 (廠內保留)																											
			60: 變頻器過載累積時間 (Sec)																											
			61~63: (廠內保留)																											
			64: 跳脫時 DC-Bus 電壓(Vdc)																											
			65: 跳脫時輸出電壓值(Vac)																											
			66: 跳脫時輸出頻率 (Hz)																											
			67: 跳脫時 IGBT 模組的溫度 (°C)	◎																										
			68: 跳脫時輸出電流值 (A)																											
			69: 跳脫時變頻器週溫(°C)	◎																										
			70~86: (廠內保留)																											
			87: DC-Bus 漣波電(Vdc)	◎																										
			88: PG 頻率 (Hz)	◎																										
			89~132: (廠內保留)																											
Pr0-08	使用者定義比例係數	0~39(不使用) 40~60000(對應於Pr1-00 參數之含意)			0																									
Pr0-09	使用者定義比例之小數點位數	0~3 (0=無小數點, 1=小數點 1 位, 2=小數點 2 位, 3=小數點 3 位)			0																									
Pr0-10	韌體版本	僅能讀取			X. XX																									
Pr0-11	EPROM 儲存設定	<table border="1"> <tbody> <tr> <td rowspan="2">Bit 0 (bxxxx0)</td> <td>0</td> <td>FWD/REV轉向命令會儲存</td> </tr> <tr> <td>1</td> <td>FWD/REV轉向命令不儲存, 關電後再通電會回復舊值</td> </tr> <tr> <td rowspan="2">Bit 1 (bxxx0x)</td> <td>0</td> <td>由PU來的頻率命令會儲存</td> </tr> <tr> <td>1</td> <td>由PU來的頻率命令不儲存, 關電後再通電會回復舊值</td> </tr> <tr> <td rowspan="2">Bit 2 (bxx0xx)</td> <td>0</td> <td>由RS-485通訊埠來的頻率命令會記憶</td> </tr> <tr> <td>1</td> <td>由RS-485通訊埠來的頻率命令不記憶, 關電後再通電會回復舊值</td> </tr> <tr> <td rowspan="2">Bit 3 (bx0xxx)</td> <td>0</td> <td>由Up/Down來的頻率命令會記憶</td> </tr> <tr> <td>1</td> <td>由Up/Down來的頻率命令不記憶, 關電後再通電會回復舊值</td> </tr> <tr> <td rowspan="2">Bit 4 (b0xxxx)</td> <td>0</td> <td>所異動的參數會記憶.</td> </tr> <tr> <td>1</td> <td>所異動的參數不記憶, 關電後再通電會回復舊值</td> </tr> </tbody> </table>	Bit 0 (bxxxx0)	0	FWD/REV轉向命令會儲存	1	FWD/REV轉向命令不儲存, 關電後再通電會回復舊值	Bit 1 (bxxx0x)	0	由PU來的頻率命令會儲存	1	由PU來的頻率命令不儲存, 關電後再通電會回復舊值	Bit 2 (bxx0xx)	0	由RS-485通訊埠來的頻率命令會記憶	1	由RS-485通訊埠來的頻率命令不記憶, 關電後再通電會回復舊值	Bit 3 (bx0xxx)	0	由Up/Down來的頻率命令會記憶	1	由Up/Down來的頻率命令不記憶, 關電後再通電會回復舊值	Bit 4 (b0xxxx)	0	所異動的參數會記憶.	1	所異動的參數不記憶, 關電後再通電會回復舊值			b00000
Bit 0 (bxxxx0)	0	FWD/REV轉向命令會儲存																												
	1	FWD/REV轉向命令不儲存, 關電後再通電會回復舊值																												
Bit 1 (bxxx0x)	0	由PU來的頻率命令會儲存																												
	1	由PU來的頻率命令不儲存, 關電後再通電會回復舊值																												
Bit 2 (bxx0xx)	0	由RS-485通訊埠來的頻率命令會記憶																												
	1	由RS-485通訊埠來的頻率命令不記憶, 關電後再通電會回復舊值																												
Bit 3 (bx0xxx)	0	由Up/Down來的頻率命令會記憶																												
	1	由Up/Down來的頻率命令不記憶, 關電後再通電會回復舊值																												
Bit 4 (b0xxxx)	0	所異動的參數會記憶.																												
	1	所異動的參數不記憶, 關電後再通電會回復舊值																												

Pr0-12	最佳化自動加/減速設定	0：直線加速,直線減速(無自動加速/減速)		0	
		1：自動加速,直線減速			
		2：直線加速,自動減速			
		3：自動加速,自動減速			
		4：直線加/減速,但以自動加/減速做失速防止			
★ Pr0-13	加/減速時間單位	0：0.01 秒		0	
		1：0.1 秒			
		2：1 秒			
Pr0-14	PWM 載波頻率上限	0=0.7kHz		##	
		1~18kHz (H1 系列:2~36 kHz)			
Pr0-15	PWM 載波頻率下限	0=0.7kHz		##	
		1~18kHz (H1 系列:2~36 kHz)			
Pr0-16	自動穩壓功能 (AVR)	0：開啟自動穩壓功能		0	
		1：取消自動穩壓功能			
		2：減速時取消自動穩壓功能			
Pr0-17	自動節能運轉(AESO)及其它	Bit 0 (bxxxx0)	0	取消自動節能運轉	b00000
			1	開啟自動節能運轉	
		Bit 1 (bxxx0x)	0	最大輸出電壓可大於電源電壓 可過調變)	
			1	最大輸出電壓等於電源電壓	
		Bit 2 (bxx0xx)	0	適用於:定轉矩通用負載	
			1	適用於:風機/水泵變轉矩負載	
		Bit 3 (bx0xxx)	0	負轉矩無滑差補償	
1	負轉矩有滑差補償				
Bit 4 (b0xxxx)	0	低噪音模式運轉			
	1	靜音模式運轉			
Pr0-18	頻率命令來源設定	0: 由數位操作器(PU)		0	
		1: 由RS485通訊埠			
		2: 由外部類比信號端子			
		3: 由外部 Up/Down 端子 (多功能輸入端子 MIx)			
		4: 由 PG 卡脈波輸入 (使用此功能需選購 PG 回授卡)			
Pr0-19	運轉命令來源設定	0：由 RS-485 通訊埠或數位操作器(PU)		0	
		1：由外部端子或數位操作器(PU)			
		2：由數位操作器(PU)			
		3：由外部端子			
Pr0-20	停車/運轉/安全模式	Bit 0 (bxxxx0)	0	以減速煞車方式停止	b00000
			1	以自由滑行方式停止	
		Bit 1 (bxxx0x)	0	外部端子運轉命令Reset後不可重新運轉	
			1	外部端子運轉命令Reset後可重新運轉	
		Bit 2 (bxx0xx)	0	外部端子不可電源通電運轉	
			1	外部端子可電源通電運轉	
		Bit 3 (bx0xxx)	0	正/反轉經過零點	
1	正/反轉不經過零點				
Bit 4 (b0xxxx)	0	高速區直線加/減速			
	1	高速區曲線加/減速			
Pr0-21	轉向限制	0 允許正反轉		0	
		1 禁止反轉			
		2 禁止正轉			
Pr0-22	停機後等待時間	0.00~60.00 Sec		0.00	

	Pr0-23	散熱風扇控制及 PID 方向	Bit 0	0	通電後風扇即運轉	b00001
			(bxxxx0)	1	運轉命令執行後風扇才運轉	
			Bit 1	0	廠內保留	
			(bxxx0x)	1		
Bit 2	0	廠內保留				
(bxx0xx)	1					
			Bit 3	0	PID可反方向運轉	
			(bx0xxx)	1	PID禁止反方向運轉	
	Pr0-24	PU 飛梭旋鈕頻率解析度	0	0.01 Hz		1
			1	0.10Hz		
			2	1.00Hz		
			3	10.00 Hz		
◎	Pr0-25	參數組別選擇	0	A 組參數		0
			1	B 組參數		
			2	由 MI3 選擇 A 組或 B 組參數		

1 參數群：基本參數

參數	參數功能	設定範圍	出廠值	客戶
★ Pr1-00	最高操作頻率	10.00~600.00Hz (H1 系列:100.0 ~6000.0Hz)	60.00/ 50.00	
★ Pr1-01	第一點頻率 1 (電動機 1 額定頻率) (Fbase 1)	0.00~600.00Hz (H1 系列:00.0 ~6000.0Hz)	60.00/ 50.00	
Pr1-02	第一點電壓 1 (電動機 1 額定電壓) (Vbase 1)	230V 機種:0.0~255.0V	230.0	
		460V 機種:0.0~510.0V	460.0	
		◎ 575V 機種:0.0~637.5V	575.0	
★ Pr1-03	第二點頻率 1 (電動機 1 中間頻率) (Fmid 1)	0.00~600.00Hz (H1 系列:00.0 ~6000.0Hz)	0.50	
Pr1-04	第二點電壓 1 (電動機 1 中間點電壓) (Fmid 1)	230V 機種:0.0~255.0V	5.0	
		460V 機種:0.0~510.0V	10.0	
		◎ 575V 機種:0.0~637.5V	12.5	
★ Pr1-05	第三點頻率 1 (電動機 1 低點頻率) (Flow 1)	0.00~600.00Hz (H1 系列:00.0 ~6000.0Hz)	0.50	
Pr1-06	第三點電壓 1 (電動機 1 低點電壓) (Vlow 1)	230V 機種:0.0~255.0V	5.0	
		460V 機種:0.0~510.0V	10.0	
		◎ 575V 機種:0.0~637.5V	12.5	
Pr1-07	0Hz 輸出電壓 1 (電動機 1 0Hz 輸出電壓) (V0Hz 1)	230V 機種:0.0~25.5V	0.0	
		460V 機種:0.0~51.0V		
		◎ 575V 機種:0.0~63.7V		
Pr1-08	啟動頻率	0.00~600.00Hz (H1 系列:00.0 ~6000.0Hz)	0.50	
Pr1-09	輸出頻率上限	0.0~150.0% (最高操作頻率 Pr1-00 之設定值=100%)	110.0	
Pr1-10	輸出頻率下限	0.0~100.0% (最高操作頻率 Pr1-00 之設定值=100%)	0.0	
Pr1-11	第一加速時間	0.00~60000 Sec	##.##	
Pr1-12	第一減速時間	0.00~60000 Sec		
Pr1-13	第二加速時間	0.00~60000 Sec		
Pr1-14	第二減速時間	0.00~60000 Sec		
Pr1-15	寸動加速時間	0.00~60000 Sec		
Pr1-16	寸動減速時間	0.00~60000 Sec		
Pr1-17	寸動頻率	0.00~600.00Hz (H1 系列:00.0 ~6000.0Hz)	6.00	
Pr1-18	第一/第二 - 加減速時間切換點的頻率	0.00~600.00Hz (H1 系列:00.0 ~6000.0Hz)	0.00	
Pr1-19	S 曲線加速起始時間	0.00~12000 Sec	0.00	
Pr1-20	S 曲線加速到達時間	0.00~12000 Sec	0.00	
Pr1-21	S 曲線減速起始時間	0.00~12000 Sec	0.00	

	Pr1-22	S 曲線減速到達時間	0.00~12000 Sec	0.00	
	Pr1-23 [Pr1-29]	減速時電壓偏移量	230 機種:-50.0~50.0 V 460V 機種:-100.0~100.0V ◎575V 機種:-125.0~125.0V	0.0	
★	Pr1-24 [Pr1-23]	禁止設定頻率 1 上限	0.00~600.00Hz (H1 系列:00.0 ~6000.0Hz)	0.00	
★	Pr1-25 [Pr1-24]	禁止設定頻率 1 下限	0.00~600.00Hz (H1 系列:00.0 ~6000.0Hz)	0.00	
★	Pr1-26 [Pr1-25]	禁止設定頻率 2 上限	0.00~600.00Hz (H1 系列:00.0 ~6000.0Hz)	0.00	
★	Pr1-27 [Pr1-26]	禁止設定頻率 2 下限	0.00~600.00Hz (H1 系列:00.0 ~6000.0Hz)	0.00	
★	Pr1-28 [Pr1-27]	禁止設定頻率 3 上限	0.00~600.00Hz (H1 系列:00.0 ~6000.0Hz)	0.00	
★	Pr1-29 [Pr1-28]	禁止設定頻率 3 下限	0.00~600.00Hz (H1 系列:00.0 ~6000.0Hz)	0.00	
★ ◎	Pr1-30	禁止設定頻率 4 上限	0.00~600.00Hz (H1 系列:00.0 ~6000.0Hz)	0.00	
★ ◎	Pr1-31	禁止設定頻率 4 下限	0.00~600.00Hz (H1 系列:00.0 ~6000.0Hz)	0.00	
★ ◎	Pr1-32	禁止設定頻率 5 上限	0.00~600.00Hz (H1 系列:00.0 ~6000.0Hz)	0.00	
★ ◎	Pr1-33	禁止設定頻率 5 下限	0.00~600.00Hz (H1 系列:00.0 ~6000.0Hz)	0.00	
★ ◎	Pr1-34	禁止設定頻率 6 上限	0.00~600.00Hz (H1 系列:00.0 ~6000.0Hz)	0.00	
★ ◎	Pr1-35	禁止設定頻率 6 下限	0.00~600.00Hz (H1 系列:00.0 ~6000.0Hz)	0.00	
★ ◎	Pr1-36	第一點頻率 2 (電動機 2 額定頻率) (Fbase 2)	0.00~600.00Hz (H1 系列:00.0 ~6000.0Hz)	60.00/ 50.00	
◎	Pr1-37	第一點電壓 2 (電動機 2 額定電壓) (Vbase 2)	230V 機種:0.0~255.0V 460V 機種:0.0~510.0V 575V 機種:0.0~637.5V	230.0 460.0 575.0	
★ ◎	Pr1-38	第二點頻率 2 (電動機 2 中間頻率) (Fmid 2)	0.00~600.00Hz (H1 系列:00.0 ~6000.0Hz)	0.50	
◎	Pr1-39	第二點電壓 2 (電動機 2 中間電壓) (Vmid 2)	230V 機種:0.0~255.0V 460V 機種:0.0~510.0V 575V 機種:0.0~637.5V	5.0 10.0 12.5	
★ ◎	Pr1-40	第三點頻率 2 (電動機 2 低點頻率) (Flow 2)	0.00~600.00Hz (H1 系列:00.0 ~6000.0Hz)	0.50	
◎	Pr1-41	第三點電壓 2 (電動機 2 低點電壓) (Vlow 2)	230V 機種:0.0~255.0V 460V 機種:0.0~510.0V 575V 機種:0.0~637.5V	5.0 10.0 12.5	
◎	Pr1-42	0Hz 電壓 2 (電動機 2 0Hz 輸出電壓) (V0Hz 2)	230V 機種:0.0~25.5V 460V 機種:0.0~51.0V 575V 機種:0.0~63.7V	0.0	

2 參數群：數位 輸入/輸出 相關參數

參數	參數功能	設定範圍	出廠值	客戶	
★	Pr2-00	外部運轉控制的組態	0：二線式(1):正轉/停止, 反轉/停止 1：二線式(2):運轉/停止, 反轉/正轉 2：三線式(MI1) 運轉, 停止, 正轉/反轉	0	
★	Pr2-01	多功能數位輸入 MI1 (三線式運轉時, STOP指定端子)	0：無定義	1	
★	Pr2-02	多功能數位輸入 MI2 (計數輸入指定端子)	1：多段速命令一	2	

★	Pr2-03	多功能數位輸入 MI3 (參數組別選擇指定端子)	2: 多段速命令二	3		
★	Pr2-04	多功能數位輸入 MI4	3: 多段速命令三	4		
★	Pr2-05	多功能數位輸入 MI5	4: 多段速命令四	5		
★	Pr2-06 (Pr2-26 Pr2-27 Pr2-28 也適用此 表)	多功能數位輸入 MI6	5: 異常復歸命令(Reset)	14		
			6: 計數器清除命令			
			7: 第一, 二加減速時間切換			
			8: 禁止加/減速命令			
			9: 強制頻率命令為 AI1			
			10: 強制頻率命令為 AI2			
			11: 強制頻率命令為 AI3			
			12: 強制停止			
			13: PID 功能取消			
			14: EF 外部異常輸入			
			15: 外部中斷(B.B.)由下往上追蹤			
			16: 外部中斷(B.B.)由上往下追蹤			
			17: 強制運轉命令由外部端子			
			18: 取消最佳化自動加速/減速			
			19: 正轉寸動命令			
			20: 反轉寸動命令			
			21: 寸動命令			
			22: 取消可編程自動程序運轉(PLC Run)			
			23: 暫停可編程自動程序運轉(PLC Run)			
			24: 頻率遞增命令(Up Command)			
			25: 頻率遞減命令(Down Command)			
			26: 零速以直流制動模式取代			
			27: 暫時停機			
			28: 取消 加/減速時齒隙暫停			
			29: 取消擺頻功能			
30: 取消啟動時速度追蹤						
31: EEPROM 不寫入						
32: 計數器觸發信號輸入(指定MI2)						
33~41: 廠內保留						
42: 電動機切換命令	◎					
43: 電動機切換完成確認信號	◎					
44: 禁止反轉	◎					
45: 禁止正轉	◎					
Pr2-07	頻率遞增/遞減之加/減速模式	Bit 0 (bxxxx0)	0	頻率遞增(Up)時依加速時間遞增	◎	
			1	頻率遞增(Up)時依 Pr2-08 所指定 速率遞增		
		Bit 1 (bxxx0x)	0	頻率遞減(Down)時依減速時間遞 減		
			1	頻率遞減(Down)時依 Pr2-08 所指定速率遞減		
		Bit 2 (bxx0xx)		廠內保留		
		Bit 3 (bx0xxx)	0	FWD/REV 端子依邊緣觸發動作 (Edge trigger)		
1	FWD/REV 端子依準位觸發動作 (Level trigger)					
Bit 4 (b0xxxx)	0	加減速中 PG 回授允許過補償	◎			
	1	加減速中 PG 回授不允許過補償	◎			
Pr2-08	頻率遞增/遞減 (Up/Down) 命 令之指定速率	0.01~1.00 Hz/mSec (也等於:10~1000Hz/Sec)		0.01		
Pr2-09	數位輸入端子濾波時間	0.000~30.000 Sec		0.005		
◎	Pr2-10	數位輸入端子極性	00000~007FF (外部端子閉合定義為"0")		h00000	
	Pr2-11	目標計數值	0~65500		0	

	Pr2-12	指定預警到達計數值	0~65500	0	
	Pr2-13	數位頻率輸出增益	1~20	1	
	Pr2-14	任意頻率到達 1	0.00~600.00Hz (H1 系列:00.0 ~6000.0Hz)	60.00/ 50.00	
	Pr2-15	任意頻率到達 1 檢出幅度	0.00~600.00Hz (H1 系列:00.0 ~6000.0Hz)	2.00	
	Pr2-16	任意頻率到達 2	0.00~600.00Hz (H1 系列:00.0 ~6000.0Hz)	60.00/ 50.00	
	Pr2-17	任意頻率到達 2 檢出幅度	0.00~600.00Hz (H1 系列:00.0 ~6000.0Hz)	2.00	
	Pr2-18	多功能數位輸出端子極性	00000~0003F	h00000	
◎	Pr2-19	多功能數位輸出端子(DO)動作延遲時間	0.000~60.000 mSec	0.003	
	Pr2-20 [Pr2-19]	多功能數位輸出 1 - Relay 1	0: 無定義	11	
	Pr2-21 [Pr2-20]	多功能數位輸出 2 - Relay 2	1: 運轉中	1	
	Pr2-22 [Pr2-21]	多功能數位輸出 3 - MO 1	2: 運轉頻率到達1 (正轉及反轉均有效)	5	
	Pr2-23 [Pr2-22]	多功能數位輸出 4 - MO 2	3: 運轉頻率到達2 (正轉及反轉均有效)	9	
◎	Pr2-24	[多功能數位輸出 5 - MO 3]	4: 任意頻率到達 1 (正轉及反轉均有效)	0	
◎	Pr2-25	[多功能數位輸出 6 - MO 4]	5: 任意頻率到達 1 (只有正轉有效)	0	
			6: 任意頻率到達 2 (正轉及反轉均有效)		
			7: 任意頻率到達 2 (只有正轉有效)		
			8: 減速中		
			9: 變頻器準備完成		
			10: 低電壓警報 (LU) (LUr)		
			11: 變頻器故障		
			12: 外部中斷中 (B.B.)		
			13: 零速(含停機)		
			14: 零速 (必須在 RUN 命令執行中)		
			15: 目標計數值到達		
			16: 指定預警計數值到達		
			17: 可編程自動程序運轉 (PLC Run) 執行中		
			18: 可編程自動程序運轉 (PLC Run) 暫停		
			19: 可編程自動程序運轉(PLC Run) 一階段運轉完成		
			20: 可編程自動程序運轉 (PLC Run)完成		
			21: OH1 過熱預警告		
			22: 加/減速時齒隙暫停中		
			23: 變頻器設定為外部端子運轉控制模式		
			24: 過轉矩檢出 1(ot1)		
			25: 脈波頻率輸出(僅適用於 M02, Pr2-23)		
			26: 軟體煞車輸出(僅適用 M01, Pr2-22)		
			27: 輔助電動機 1		
			28: 輔助電動機 2		
			29: 輔助電動機 3		
			30: 過轉矩檢出 2 (ot2)		
31: OH2 過熱預警告	◎				
32: 電動機切換輸出	◎				
33~47: 廠內保留					
48: 主速頻率命令執行中					
49: 自動程序運轉(PLC Run)第 1 段執行中					
50: 自動程序運轉(PLC Run)第 2 段執行中					
51: 自動程序運轉(PLC Run)第 3 段執行中					
52: 自動程序運轉(PLC Run)第 4 段執行中					
53: 自動程序運轉(PLC Run)第 5 段執行中					
54: 自動程序運轉(PLC Run)第 6 段執行中					

			55: 自動程序運轉(PLC Run)第 7 段執行中		
			56: 自動程序運轉(PLC Run)第 8 段執行中		
			57: 自動程序運轉(PLC Run)第 9 段執行中		
			58: 自動程序運轉(PLC Run)第 10 段執行中		
			59: 自動程序運轉(PLC Run)第 11 段執行中		
			60: 自動程序運轉(PLC Run)第 12 段執行中		
			61: 自動程序運轉(PLC Run)第 13 段執行中		
			62: 自動程序運轉(PLC Run)第 14 段執行中		
			63: 自動程序運轉(PLC Run)第 15 段執行中		
			64~79: 廠內保留		
◎	Pr2-26	[多功能數位輸入 MI7]	如同 Pr2-01~Pr2-06	0	
◎	Pr2-27	[多功能數位輸入 MI8]			
◎	Pr2-28	[多功能數位輸入 MI9]			

3 參數群：類比輸入/輸出 相關參數

參數	參數功能	設定範圍	出廠值	客戶
Pr3-00	類比輸入相加減功能	0 可相加減	0	
		1 不可相加減		
Pr3-01	類比輸入濾波時間	0.00~2.00 Sec	0.10	
Pr3-02 AI2 (Pr3-06)) 及 AI3 (Pr3-11)) 也適用 此表	AI1 類比輸入功能	0: 無功能	1	
		1: 頻率命令(Pr1-00=100%)		
		2: 調整第一加/減速時間(如同 Pr1-11, Pr1-12)		
		3: 恆速中過電流失速防止準位調整=Pr5-12 (如同 Pr5-12)		
		4: 加速中過電流失速防止準位 (如同 Pr5-10)		
		5: 過轉矩檢出準位 1 調整(如同 Pr5-16)		
		6: 電動機 1 自動轉矩補償調整(如同 Pr5-01)		
		7: 頻率命令來源單一為 AI1 時的輔助頻率信號		
		8: 頻率命令來源單一為 AI2 時的輔助頻率信號		
		9: 頻率命令來源單一為 AI3 時的輔助頻率信號		
		10: 主頻的輔助頻率信號		
		11: PID 回授信號		
		12: PID 偏移信號 (如同 Pr7-05)		
		13: 直流制動電流準位調整(如同 Pr6-00)		
		14: 運轉中輸出電壓調整 (僅適用於 AI1: Pr3-02)		
15: 外部溫度信號顯示及保護				
Pr3-03	AI1 類比輸入偏壓	-10.00~10.00V	0.00	
Pr3-04	AI1 類比輸入增益	-500.0~+500.0%	100.0	
Pr3-05	AI1 偏壓模式	0 以偏壓為中心	0	
		1 低於偏壓=偏壓		
		2 高於偏壓=偏壓		
		3 以偏壓為中心取絕對值		
Pr3-06	AI2 類比輸入功能	如同 Pr3-02	0	
Pr3-07	AI2 類比輸入偏壓	0.00~20.00mA	4.00	
Pr3-08	AI2 類比輸入增益	-500.0~+500.0%	100.0	
Pr3-09	AI2 類比輸入偏壓模式	0 以偏壓為中心	1	
		1 低於偏壓=偏壓		
		2 高於偏壓=偏壓		
		3 以偏壓為中心取絕對值		
Pr3-10	AI2 斷線處置選擇	0 不處理	0	
		1 以斷線前頻率繼續運轉		
		2 立即依減速停車方式停止		
		3 立即依滑行方式停止並顯示AcI.		
Pr3-11	AI3 類比輸入功能	如同 Pr3-02	0	
Pr3-12	AI3 類比輸入偏壓	-10.00~10.00V	0.00	
Pr3-13	AI3 類比輸入增益	-500.0~+500.0%	100.0	

Pr3-14	AI3 類比輸入偏壓模式	0	以偏壓為中心	0
		1	低於偏壓=偏壓	
		2	高於偏壓=偏壓	
		3	以偏壓為中心取絕對值	
Pr3-15	類比輸出 1 功能選擇(A01)	0	輸出頻率	0
Pr3-16	類比輸出 2 功能選擇(A02)	1	命令頻率	0
		2	電動機速度	
		3	輸出電流	
		4	輸出電壓	
		5	DC BUS 電壓	
		6	功率因數	
		7	輸出功率	
		8	AI1 值	
		9	AI2 值	
		10	AI3 值	
		11~12	廠內保留	
		13	輸出電壓命令	
		14	計數值	
		15	依 Pr3-21 之設定值	
16~23	廠內保留			
24	定義成多功能數位輸出(MOx)			
Pr3-17	A01 類比輸出增益	-900.0~900.0%		100.0
Pr3-18	A02 類比輸出增益	-900.0~900.0%		80.0
Pr3-19	A01 類比輸出偏壓	-10.00~10.00V		0.00
Pr3-20	A02 類比輸出偏壓	0.00~20.00mA		4.00
Pr3-21	使用者定義的類比輸出特定值	0.0~100.0%		0.0

4 參數群：多段速運轉(MSS Run)與可編程自動程序運轉(PLC Run)相關參數

參數	參數功能	設定範圍	出廠值	客戶
Pr4-00	PLC Run 或 MSS Run 第一段速度	0.00~600.00Hz (H1 系列:00.0~6000.0Hz)	0.00	
Pr4-01	PLC Run 或 MSS Run 第二段速度	0.00~600.00Hz (H1 系列:00.0~6000.0Hz)	0.00	
Pr4-02	PLC Run 或 MSS Run 第三段速度	0.00~600.00Hz (H1 系列:00.0~6000.0Hz)	0.00	
Pr4-03	PLC Run 或 MSS Run 第四段速度	0.00~600.00Hz (H1 系列:00.0~6000.0Hz)	0.00	
Pr4-04	PLC Run 或 MSS Run 第五段速度	0.00~600.00Hz (H1 系列:00.0~6000.0Hz)	0.00	
Pr4-05	PLC Run 或 MSS Run 第六段速度	0.00~600.00Hz (H1 系列:00.0~6000.0Hz)	0.00	
Pr4-06	PLC Run 或 MSS Run 第七段速度	0.00~600.00Hz (H1 系列:00.0~6000.0Hz)	0.00	
Pr4-07	PLC Run 或 MSS Run 第八段速度	0.00~600.00Hz (H1 系列:00.0~6000.0Hz)	0.00	
Pr4-08	PLC Run 或 MSS Run 第九段速度	0.00~600.00Hz (H1 系列:00.0~6000.0Hz)	0.00	
Pr4-09	PLC Run 或 MSS Run 第十段速度	0.00~600.00Hz (H1 系列:00.0~6000.0Hz)	0.00	
Pr4-10	PLC Run 或 MSS Run 第十一段速度	0.00~600.00Hz (H1 系列:00.0~6000.0Hz)	0.00	
Pr4-11	PLC Run 或 MSS Run 第十二段速度	0.00~600.00Hz (H1 系列:00.0~6000.0Hz)	0.00	
Pr4-12	PLC Run 或 MSS Run 第十三段速度	0.00~600.00Hz (H1 系列:00.0~6000.0Hz)	0.00	
Pr4-13	PLC Run 或 MSS Run 第十四段速度	0.00~600.00Hz (H1 系列:00.0~6000.0Hz)	0.00	
Pr4-14	PLC Run 或 MSS Run 第十五段速度	0.00~600.00Hz (H1 系列:00.0~6000.0Hz)	0.00	
Pr4-15	PLC Run 或 MSS Run 主速時間	0.0~6550.0 Sec	0.0	
Pr4-16	PLC Run 或 MSS Run 第一段時間	0.0~6550.0 Sec	0.0	
Pr4-17	PLC Run 或 MSS Run 第二段時間	0.0~6550.0 Sec	0.0	
Pr4-18	PLC Run 或 MSS Run 第三段時間	0.0~6550.0 Sec	0.0	
Pr4-19	PLC Run 或 MSS Run 第四段時間	0.0~6550.0 Sec	0.0	
Pr4-20	PLC Run 或 MSS Run 第五段時間	0.0~6550.0 Sec	0.0	
Pr4-21	PLC Run 或 MSS Run 第六段時間	0.0~6550.0 Sec	0.0	
Pr4-22	PLC Run 或 MSS Run 第七段時間	0.0~6550.0 Sec	0.0	
Pr4-23	PLC Run 或 MSS Run 第八段時間	0.0~6550.0 Sec	0.0	
Pr4-24	PLC Run 或 MSS Run 第九段時間	0.0~6550.0 Sec	0.0	
Pr4-25	PLC Run 或 MSS Run 第十段時間	0.0~6550.0 Sec	0.0	

	Pr4-26	PLC Run 或 MSS Run 第十一段時間	0.0~6550.0 Sec	0.0		
	Pr4-27	PLC Run 或 MSS Run 第十二段時間	0.0~6550.0 Sec	0.0		
	Pr4-28	PLC Run 或 MSS Run 第十三段時間	0.0~6550.0 Sec	0.0		
	Pr4-29	PLC Run 或 MSS Run 第十四段時間	0.0~6550.0 Sec	0.0		
	Pr4-30	PLC Run 或 MSS Run 第十五段時間	0.0~6550.0 Sec	0.0		
	Pr4-31	PLC Run 或 MSS Run 時間倍數	1~10	1		
◎	Pr4-32	PLC Run 或 MSS Run 各段速之旋轉方向	00000~07FFF (0:正轉;1:反轉)	h00000		
	Pr4-33	(PLC Run)可編程自動程序 運轉模式	Bit 0 (bxxxx0)	0 旋轉方向由Pr4-32決定 1 旋轉方向由主速決定	b01000	
			Bit 1 (bxxx0x)	0 無零速間隔運轉(連續模式) 1 有零速間隔運轉(STOP模式)		
			Bit 2 (bxx0xx)	0 暫停時以零速運轉 1 暫停時以該段原定速度運轉		
			Bit 3 (bx0xxx)	0 電源中斷復電後,再啟動時從頭執行		◎
				1 電源中斷復電後,再啟動時從中斷處繼續執行		
			Pr4-34	(PLC Run)可編程自動程序 運轉執行週期		0:可編程自動程序運轉無效 1~60000:執行1~60000次週期 60001:持續循環運轉
	Pr4-35	(PLC Run)可編程自動程序 運轉完成後之動作	0~15:依主速或多段速之一運轉(0=主速) 16:停止運轉	16		
	Pr4-36	(MSS Run)多段速運轉模式	Bit 0 (bxxxx0)	0 旋轉方向由Pr4-32決定 1 旋轉方向由主速決定	b00001	
			Bit 1 (bxxx0x)	0 各段速的運轉時間由依MIx之多 段速端子控制 1 各段速的運轉時間由 Pr4-15~Pr4-30的設定值決定		
			Bit 2 (bxx0xx)	0 無零速間隔運轉(連續模式) 1 有零速間隔運轉(STOP模式)		
			Bit 3 (bx0xxx)	0 PID偏移無效		◎
				1 多段速 + PID 偏移有效		
			Bit 4 (b0xxxx)	0 運轉中JOG命令無效 1 運轉中JOG命令有效		◎

5 參數群：電動機調適及保護參數

參數	參數功能	設定範圍	出廠值	客戶
★ Pr5-00	電動機 1 滿載電流	安培(變頻器額定輸出電流之10~120%)	##.##	
Pr5-01	電動機 1 轉矩補償	0.0~25.0 %	0.0	
◎ Pr5-02	電動機 1 滑差補償	0~20% RPM (依Pr1-01設定頻率對應之2極至20極電動機的同步轉速*20%)	0	
Pr5-03	電動機 1 極數	2~20	4	
Pr5-04	電動機 1 R1 值	0.000~65.535 Ω	0.0	
★ Pr5-05	電動機參數自動調適及控制模式切換	0 不自動調適	0	
		1 依Pr5-00所設定的電流值執行電動機參數自動調適並切換成無感測向量控制模式		
		2 重置已調適的參數並恢復成V/F模式		
★ Pr5-06	低電壓保護恢復準位	230V 機種:160~220Vac	180	
		460V 機種:320~440Vac	360	
		◎575V 機種:400~550Vac	450	
Pr5-07	過電壓失速防止準位	230V 機種:320~500VDC	380	
		460V 機種:640~1000VDC	760	
		◎575V 機種:800~1250VDC	950	
Pr5-08	回升動態煞車準位設定	230V 機種:320~500VDC	373	
		460V 機種:640~1000VDC	746	
		◎575V 機種:800~1250VDC	932	

Pr5-09	電源欠相保護	0	提出警告但繼續運轉 (若輸出電流在額定的50%以下)			0
		1	提出警告並且減速停止			
		2	提出警告並且滑行停止			
Pr5-10	恆定轉矩輸出區加速時過電流失速防止準位	安培 (變頻器額定輸出電流之 10~250%)			##.##	
Pr5-11	恆定馬力輸出區加速時過電流失速防止下限準位	安培 (變頻器額定輸出電流之 0~250%)			##.##	
Pr5-12	恆定轉矩輸出區恆速運轉中過電流失速防止準位	安培 (變頻器額定輸出電流之 10~250%)			##.##	
Pr5-13	恆定馬力輸出區恆速運轉中過電流失速防止下限準位	安培 (變頻器額定輸出電流之 0~250%)			##.##	
Pr5-14	失速防止動作時之減速時間	0.50~120.00 Sec			3.00	
Pr5-15	過轉矩檢出功能 1 選擇 (ot1)	0	不檢測			0
		1	恆速運轉中過轉矩檢出時停止運轉			
		2	恆速運轉中過轉矩檢出時繼續運轉			
		3	運轉中過轉矩檢出時停止運轉			
		4	運轉中過轉矩檢出時繼續運轉			
Pr5-16	過轉矩檢出準位 1	安培 (變頻器額定輸出電流之 10~250%)			##.##	
Pr5-17	過轉矩檢出時間 1	0.0~60.0 Sec			0.1	
Pr5-18	電動機 1 電子熱動電驛選擇 (oL1)	0	電子熱動電驛功能關閉			0
		1	使用變頻專用電動機 (獨立散熱, 不需考量變頻器的輸出頻率)			
		2	使用標準電動機 (同軸散熱, 需考量變頻器的輸出頻率)			
Pr5-19	電動機 1 電子熱動電驛動作時間	30~600 Sec			60	
Pr5-20	IGBT 過熱預警告溫度設定 1 (OH1)	0.0~110.0°C			85.0	
◎ Pr5-21	過轉矩檢出功能 2 選擇 (ot2)	0	不檢測			0
		1	恆速運轉中過轉矩檢出時停止運轉			
		2	恆速運轉中過轉矩檢出時繼續運轉			
		3	運轉中過轉矩檢出時停止運轉			
		4	運轉中過轉矩檢出時繼續運轉			
◎ Pr5-22	過轉矩檢出準位 2	安培 (變頻器額定輸出電流之 10~250%)			##.##	
◎ Pr5-23	過轉矩檢出時間 2	0.0~60.0 Sec			0.1	
Pr5-24 [Pr5-21]	最後一次異常記錄	0: 無異常記錄	16: HPF (硬體保護迴路異常)	32: ot2 (過轉矩 2 檢出動作)	0	
Pr5-25 [Pr5-22]	前一次異常記錄	1: Oc (輸出側過電流)	17: oH1 (IGBT 模組內部或散熱器溫度過高)	33: oL2 (電動機 2 過負載)	0	
Pr5-26 [Pr5-23]	前二次異常記錄	2: oU (DC-bus 過電壓)	18: oH2 (變頻器箱體過溫過高) (或其它特定監測點溫度超過容許值)	34: rnot (電動機切換異常)	0	
Pr5-27 [Pr5-24]	前三次異常記錄	3: GF (輸出側對地漏電)	19: SoFt (預充電限流迴路異常)		0	
◎ Pr5-28	前四次異常記錄	4: SC (IGBT 模組異常)	20: ACI. (AI2 類比輸入迴路斷線)	36: LUr (運轉中 DC-bus 低電壓)	0	
◎ Pr5-29	前五次異常記錄	5: oL (變頻器過載)	21: ASC (RS485 串列埠通訊傳輸逾時)	37: oUd (減速時 DC-bus 過電壓)	0	
◎ Pr5-30	前六次異常記錄	6: oL1 (電動機 1 過負載)	22: PI.d (PID 回授訊號異常)	38: x CoPY (參數複製錯誤)	0	
◎ Pr5-31	前七次異常記錄	7: ot1 (過轉矩 1 檢出動作)	23: Pu (操作器(PU)斷線逾時)	39: LU (DC-bus 低電壓)	0	

◎	Pr5-32	前八次異常記錄	8: oCn (恆速運轉中輸出側過電流)	24: tunE (電動機參數調適失敗)	40: bb (外部中斷)	0	
◎	Pr5-33	前九次異常記錄	9: oCA (加速時輸出側過電流)	25: bF (動能煞車迴路異常)		0	
◎	Pr5-34	前十次異常記錄	10: oCd (減速時輸出側過電流)	26: PG (PG 斷線/異常)		0	
◎	Pr5-35	前十一次異常記錄	11: EP1 (EEPROM 記憶體資料讀出異常)	27: PHL DC-Bus連波電壓過高 (電源欠相)		0	
◎	Pr5-36	前十二次異常記錄	12: EP2 (EEPROM 記憶體資料寫入異常)	28: CC (停機中電流訊號異常)		0	
◎	Pr5-37	前十三次異常記錄	13: EF (外部異常輸入動作)	29: CPu (變頻器偵測線路異常)		0	
◎	Pr5-38	前十四次異常記錄	14: Ct1 (U相電流傳感迴路或A/D轉換迴路異常)	30: FAn (散熱風扇異常)		0	
◎	Pr5-39	前十五次異常記錄	15: Ct2 (W相電流傳感迴路或A/D轉換迴路異常)	31: An1 (類比輸入信號異常)		0	
★	Pr5-40	電動機 2 滿載電流	安培 (變頻器額定輸出電流之 10~120%)			##.##	
◎	Pr5-41	電動機 2 自動轉矩補償	0.0~25.0%			0.0	
◎	Pr5-42	電動機 2 滑差補償	0~20% RPM (依 Pr1-36 設定頻率對應之 2 極至 20 極電動機的同步轉速*20%)			0	
◎	Pr5-43	電動機 2 極數	2~20			4	
◎	Pr5-44	電動機 2 RI 值	0.000~65.535Ω			0.0	
◎	Pr5-45	電動機 2 電子熱動電驛選擇(oL2)	0	電子熱動電驛功能關閉		0	
			1	使用變頻專用電動機 (獨立散熱, 不需考量變頻器的輸出頻率)			
			2	使用標準電動機 (同軸散熱, 需考量變頻器的輸出頻率)			
◎	Pr5-46	電動機 2 電子熱動電驛動作時間	30~600 Sec			60	
◎	Pr5-47	變頻器過熱預告溫度設定 2 (OH2)	0.0~110.0°C			75.0	
◎	Pr5-48	電動機切換完成確認信號之允許等待時間	0.00~60.00 Sec			0.05	
◎	Pr5-49	電動機切換模式	Bit 0 (bxxxx0)	0	運轉中不可切換	b00000	
				1	運轉中可切換		
			Bit 1 (bxxx0x)	0	切換時不需等待確認信號		
				1	切換時必需等待確認信號		

6 參數群：特殊參數

參數	參數功能	設定範圍	出廠值	客戶
Pr6-00	直流制動電流準位	安培 (變頻器額定輸出電流之 0~125%)	##.##	
Pr6-01	啟動時直流制動時間	0.00~60.00 Sec	0.00	
Pr6-02	停車時直流制動時間	0.00~60.00 Sec	0.00	
Pr6-03	停車時直流制動起始頻率	0.00~600.00Hz (H1 系列:00.0 ~6000.0Hz)	0.00	
Pr6-04	直流制動電壓的增加速率	0.01~300.00%	20.00	
Pr6-05	瞬時停電後再運轉選擇	0	瞬時停電後不繼續運轉	0
		1	瞬時停電後由停電前速度往下追蹤繼續運轉	
		2	瞬時停電後由啟動頻率往上追蹤繼續運轉	
Pr6-06	允許瞬時停電之最長時間設定	0.1~5.0 Sec	2.0	
Pr6-07	速度追蹤之延遲時間設定(B.B. 時間)	0.1~5.0 Sec	0.5	
Pr6-08	速度追蹤動作電流準位	安培(變頻器額定輸出電流之 20~200%)	##.##	
Pr6-09	速度追蹤減速時間	0.50~120.00 Sec	3.00	

Pr6-10	異常自動再啟動次數	0~30	0
Pr6-11	啟動時速度追蹤	0	不執行啟動時速度追蹤
		1	依頻率命令做速度追蹤
		2	只執行正向速度追蹤
		3	只執行反向速度追蹤
		4	執行正/反向速度追蹤 (正向優先)
		5	執行反/正向速度追蹤 (反向優先)
Pr6-12	正向啟動時速度追蹤頻率	0.00~600.00Hz (H1 系列:00.0 ~6000.0Hz)	60.00/ 50.00
Pr6-13	反向啟動時速度追蹤頻率	0.00~600.00Hz (H1 系列:00.0 ~6000.0Hz)	60.00/ 50.00
Pr6-14	加速時齒隙暫停時間	0.00~60.00 Sec	0.00
Pr6-15	加速時齒隙暫停頻率	0.00~600.00Hz (H1 系列:00.0 ~6000.0Hz)	6.00
Pr6-16	減速時齒隙暫停時間	0.00~60.00 Sec	0.00
Pr6-17	減速時齒隙減速暫停頻率	0.00~600.00Hz (H1 系列:00.0 ~6000.0Hz)	6.00
Pr6-18	齒隙暫停中之電流限制	安培 (變頻器額定輸出電流之 0~150%)	##.##
Pr6-19	擺頻功能跳躍頻率	0.00~100.00Hz	0.00
Pr6-20	擺頻功能頻率寬度	0.00~200.00Hz	0.00

7 參數群: PID 及 通訊傳輸相關參數

參數	參數功能	設定範圍	出廠值	客戶
Pr7-00	PID 比例值增益 (P)	0~500%	80	
Pr7-01	PID 積分時間 (I)	0.00~100.00 Sec	1.00	
		0.00: 無積分		
Pr7-02	PID 微分時間 (D)	0.00~5.00 Sec	0.00	
Pr7-03	PID 積分上限值	0.0~100.0%	100.0	
Pr7-04	PID 輸出頻率限制	0.0~100.0%	100.0	
Pr7-05	PID 偏移量	-100.0~+100.0%	0.0	
Pr7-06	PID 濾波延遲時間	0.000~0.100 Sec	0.000	
Pr7-07	PID 回授訊號異常檢出時間	0.0~6000.0 Sec	0.0	
Pr7-08	PID 回授訊號錯誤處置方式	0	0	
		1		
		2		
Pr7-09	操作器 (PU) 斷線處置方式	0	0	
		1		
Pr7-10	操作器 (PU) 斷線逾時檢出	0.0: 不檢出且繼續運轉	0.0	
		0.1~60.0 Sec		
Pr7-11	RS-485 串列通訊埠位址	1~254	1	
Pr7-12	RS-485 串列通訊埠傳輸速率	1.2~125 k bps (位元/秒)	9.6	
Pr7-13	RS-485 串列通訊埠傳輸錯誤處置	0	3	
		1		
		2		
		3		
Pr7-14	RS-485 串列通訊埠傳輸逾時檢出	0.0: 無傳輸逾時檢出	0.0	
		0.1~60.0 Sec		
Pr7-15	RS-485 通訊協定	0: 7, N, 2 ASCII	0	
		1: 7, E, 1 ASCII		
		2: 7, 0, 1 ASCII		
		3: 7, E, 2 ASCII		
		4: 7, 0, 2 ASCII		
		5: 8, N, 1 ASCII		
		6: 8, N, 2 ASCII		
		7: 8, E, 1 ASCII		
8: 8, 0, 1 ASCII				

			9: 8, E, 2 ASCII		
			10: 8, 0, 2 ASCII		
			11: 8, N, 1 RTU		
			12: 8, N, 2 RTU		
			13: 8, E, 1 RTU		
			14: 8, 0, 1 RTU		
			15: 8, E, 2 RTU		
			16: 8, 0, 2 RTU		

8 參數群：風機、水泵控制相關參數

參數	參數功能	設定範圍		出廠值	客戶
★ Pr8-00	V/F 曲線選擇	0	V/F 曲線由參數群 1 設定	0	
		1	1.5次方曲線		
		2	2次方曲線		
Pr8-01	輔助電動機啟動頻率	0.00~600.00Hz (H1 系列:00.0 ~6000.0Hz)		0.00	
Pr8-02	輔助電動機停止頻率	5.00~600.00Hz (H1 系列:50.0 ~6000.0Hz)		5.00	
Pr8-03	輔助電動機啟動延時	0.0~6000.0Sec		0.0	
Pr8-04	輔助電動機停止延時	0.0~6000.0Sec		0.0	
Pr8-05	睡眠頻率	0.00~600.00Hz (H1 系列:00.0 ~6000.0Hz)		0.00	
Pr8-06	甦醒頻率	0.00~600.00Hz (H1 系列:00.0 ~6000.0Hz)		0.00	
Pr8-07	睡眠時間	0.0~6000.0 Sec		0.0	

9 參數群：速度回授控制相關參數 (使用此參數群需選購 PG 回授卡)

參數	參數功能	設定範圍		出廠值	客戶	
★ Pr9-00	PG 旋轉一圈的脈波數	1~5000 PPR		1024		
★ Pr9-01	PG 功能及型式設定	0	無使用PG 功能	0		
		1	雙向使用, A/B 相脈波列, A 相超前B 相90 度視為正轉			
		2	雙向使用, A/B 相脈波列, B 相超前A 相90 度視為正轉			
		3	(廠內保留)			
		4	PID 回授反向			⊙
		5	PID 回授正向			⊙
		6	(廠內保留)			
		7	(廠內保留)			
		8	反轉頻率命令 (Pr0-18=4)			⊙
		9	正轉頻率命令 (Pr0-18=4)			⊙
10	(廠內保留)					
Pr9-02	PG 速度顯示濾波時間	0.000~1.000 秒		0.03		
Pr9-03	PG 回授速度控制比例增益值 (P)	0.0~500.0%		20.0		
Pr9-04	PG 回授速度控制積分時間 (I)	0.00: 無積分		0.50		
		0.00 ~10.00 Sec				
Pr9-05	PG 回授速度控制微分時間 (D)	0.00~5.00 秒		0.00		
Pr9-06	PG 回授速度控制滑差補償限制	0.00~150.00Hz		20.00		
Pr9-07	PG 回授速度控制訊號錯誤處理方式	0	警告但繼續運轉	0		
		1	警告且減速停止			
		2	警告且滑行停止			
Pr9-08	PG 回授速度控制異常偵測時間	0.00~10.00 秒		0.10		
⊙ Pr9-09	PG 回授速度控制補償限制	0~900 RPM		90		

錯誤訊息指示與故障排除

變頻器本身有過電壓，低電壓及過電流等多項警示訊息及保護功能，一旦異常故障發生，保護功能動作，變頻器停止輸出，電動機滑行停止。異常原因會顯示於數位操作器，同時異常接點輸出端子動作，請依變頻器之異常顯示符號對照其異常原因及處置方法。異常記錄會儲存在變頻器內部記憶體（可記錄最近 16 次異常訊息），可由數位操作器讀出也可經通信方式讀取。而當發生警告機能動作時，僅數位操作器上閃爍顯示警告內容（有些例外），異常接點輸出端子不動作。

變頻器由 IC，電阻，電容，電晶體等電子零件及冷卻風扇，電驛等為數眾多的零件組成，這些零件不是能夠永久不壞，不是可以永久使用，即使在正常環境運用，若超過其耐用年限，則容易發生故障。因此要實施預防性定期檢查，把不符合規格要求或已有品質不良品發掘出來，及早摒除會造成變頻器不良之潛在原因，同時也把逾期耐用年限的各部品趁機會換掉，以確保良好可安全地運轉。平常就需要從外部目視檢查變頻器的運轉，確認沒有異常狀況發生，並檢查是否有下列警示訊息發生。

異常跳脫復歸：

當異常發生後，需等待5秒後(oC、GF、SC異常需等待60秒後)，待消除警報原因後，才能有效執行異常復歸。執行異常復歸方式有三：

1. 由PU操作器上的RESET鍵
2. 將外部端子設定為”異常復歸指令”並導通此端子
3. 以通訊方式傳送異常復歸指令

任何異常警報解除前，應使運轉信號為斷路(OFF)狀態，以防止異常訊號復歸後立即重新運轉而導致機械損害或人員傷亡。

異常訊息及排除方法

顯示符號	異常現象說明（符號字元） {異常碼}	排除方法
oC	輸出側過電流 (oC) {01}	<ul style="list-style-type: none"> ◆ 檢查與電動機連接線是否有短路現象或接地 ◆ 延長加速時間(Pr1-11, Pr1-12) ◆ 檢查電動機額定與變頻器額定是否相匹配 ◆ 檢查變頻器與電動機的螺絲有無鬆動 ◆ 檢查電動機是否有超額負載 ◆ 是否驅動特殊馬達(高速馬達或脈衝馬達) ◆ 異常排除需等待60秒後，才能有效復歸(RESET)
oU	DC-bus過電壓 (oU) {02}	<ul style="list-style-type: none"> ◆ 檢查電源電壓是否在變頻器額定輸入電壓範圍內，並監測是否有突波電壓產生 ◆ 若是由於電動機慣量回升電壓，造成變頻器內部直流高壓側電壓過高，可加長減速時間或加裝煞車器及煞車電阻。(選配)
oUd	減速時DC-bus過電壓 (oUd) {37}	<ul style="list-style-type: none"> ◆ 檢查電源電壓是否在變頻器額定輸入電壓範圍內，並監測是否有突波電壓產生 ◆ 電動機慣量回升電壓，造成變頻器內部直流高壓側電壓過高，可加長減速時間或加裝煞車器及煞車電阻。(選用)
GF	輸出側對地漏電 (GF) {03} 變頻器偵測到輸出端對地漏電且接地電流高於變頻器額定電流的50%以上。 注意：此保護係針對變頻器而非人體。	<ul style="list-style-type: none"> ◆ 檢查與電動機連線是否有短路現象或接地 ◆ 確定IGBT功率模組是否損壞 ◆ 檢查輸出側接線是否絕緣不良 ◆ 異常排除需等待60秒後，才能有效復歸(RESET)

<p>SC</p>	<p>IGBT模組異常 (SC){04} 變頻器偵測到 IGBT 模組轉態異常</p>	<ul style="list-style-type: none"> ◆ 檢查電動機的阻抗及絕緣是否正常 ◆ 檢查與電動機連接線是否有短路現象 ◆ 將變頻器的電動機連接線切斷後，若仍發生則確定IGBT功率模組異常--送廠維修 ◆ 異常排除需等待60秒後，才能有效復歸(RESET)
<p>oL</p>	<p>變頻器過載 (oL){05} 輸出電流長時間超過可承受的電流 G1系列:額定電流的150%可承受60秒 H1系列:額定電流的150%可承受60秒 P1系列:額定電流的125%可承受60秒</p>	<ul style="list-style-type: none"> ◆ 減輕負載及延長加速時間 ◆ 檢查電動機是否過負載 ◆ 減低(Pr5-01) 轉矩提升設定值 ◆ 選用較大輸出容量變頻器
<p>oL 1</p>	<p>電動機1 過負載 (oL1) {06} (電子熱動電驛1保護動作)</p>	<ul style="list-style-type: none"> ◆ V/F 1曲線設定是否適當 ◆ 是否長時間低速運轉 ◆ 檢查電動機1是否過載 ◆ 檢查(Pr5-00) 電動機1額定電流值是否適當 ◆ 檢查電子熱動電驛1功能設定(Pr5-18~ Pr5-19) ◆ 增加電動機1容量
<p>ot 1</p>	<p>過轉矩1檢出動作 (ot1) {07}</p>	<ul style="list-style-type: none"> ◆ 檢查電動機1負載是否過大 ◆ 檢查(Pr5-00) 電動機1額定電流值是否適當 ◆ 檢查過轉矩檢出位準1設定值(Pr5-15~Pr5-17) ◆ 機械負載是否異常 ◆ 增加電動機1容量，選用較大輸出容量變頻器
<p>oCn</p>	<p>恆速運轉中輸出側過電流 (oCn) {08}</p>	<ul style="list-style-type: none"> ◆ 輸出連接線是否絕緣不良 ◆ 檢查電動機是否堵死 ◆ 更換較大輸出容量的變頻器
<p>oCA</p>	<p>加速時輸出側過電流 (oCA) {09}</p>	<ul style="list-style-type: none"> ◆ 檢查變頻器與電動機的螺絲有無鬆動 ◆ 檢查輸出連接線是否絕緣不良 ◆ 延長加速時間 ◆ 減低(Pr5-01) 轉矩提升設定值 ◆ 更換較大輸出容量的變頻器
<p>oCd</p>	<p>減速時輸出側過電流 (oCd) {10}</p>	<ul style="list-style-type: none"> ◆ 輸出連接線是否絕緣不良 ◆ 延長減速時間 ◆ 更換較大輸出容量的變頻器
<p>EP 1</p>	<p>EEPROM記憶體資料讀出異常 (EP1) {11}</p>	<ul style="list-style-type: none"> ◆ 檢查變頻器的電源電壓是否在容許範圍內 ◆ 待顯示幕熄滅後再重新上電 ◆ 將參數復歸為出廠設定,若無效則送廠維修
<p>EP2</p>	<p>EEPROM記憶體資料寫入異常 (EP2) {12}</p>	
<p>EF</p>	<p>外部異常輸入動作 (EF) {13} (Pr2-01~Pr2-06或Pr2-26~Pr2-28 之一 =14 且作動)</p>	<ul style="list-style-type: none"> ◆ 清除外部故障來源後執行RESET命令即可復歸
<p>Ct 1</p>	<p>U 相電流傳感迴路或CPU板A/D轉換迴路異常 (Ct1) {14}</p>	<ul style="list-style-type: none"> ◆ 將變頻器的電源切斷後，待顯示幕熄滅後再重新上電後，若再次出現異常則送廠維修。 ◆ 更換控制板或U 相電流傳感器

Ct2	W 相電流傳感迴路或CPU板A/D轉換迴路異常 (Ct2) {15}	<ul style="list-style-type: none"> ◆ 將變頻器的電源切斷後，待顯示幕熄滅後再重新上電後，若再次出現異常則送廠維修。 ◆ 更換控制板或W 相電流傳感器
HPF	硬體保護迴路異常 (HPF) {16}	<ul style="list-style-type: none"> ◆ 將變頻器的電源切斷後，待顯示幕熄滅後再重新上電後，若再次出現異常則送廠維修。
OH1	IGBT模組內部或散熱器溫度過高 (OH1) {17}	<ul style="list-style-type: none"> ◆ 檢查風扇動作是否正常 ◆ 檢查環境溫度是否過高 ◆ 檢查散熱器是否有異物或油污覆蓋 ◆ 檢查散熱風道是否暢通 ◆ 檢查是否有足夠散熱空間及足夠冷空氣對流
OH2	變頻器箱體週溫過高 (OH2) {18} (或其它特定監測點溫度超過容許值)	<ul style="list-style-type: none"> ◆ 檢查風扇動作是否正常 ◆ 檢查環境溫度是否過高 ◆ 檢查是否有足夠散熱空間及足夠冷空氣對流 ◆ 檢查是否按裝變頻器的箱體內部積熱
Soft	預充電限流迴路異常 (Soft) {19}	<ul style="list-style-type: none"> ◆ 將變頻器的電源切斷後，待顯示幕熄滅後再重新上電後，若再次出現異常則送廠維修。
AI1	AI2 類比輸入迴路斷線 (AI1) {20}	<ul style="list-style-type: none"> ◆ 檢查AI2 信號是否小於4mA ◆ 檢查AI2 配線
ASC	RS485串列埠通訊傳輸逾時 (ASC) {21}	<ul style="list-style-type: none"> ◆ 檢查RS-485配線
PI.d	PID回授訊號異常 (PI.d) {22}	<ul style="list-style-type: none"> ◆ 檢查PID回授配線 ◆ 檢查PID參數是否設定恰當 ◆ 設定為有PG 回授控制時, Encoder 設定參數是否正確。
Pu	操作器(PU)斷線逾時 (Pu) {23}	<ul style="list-style-type: none"> ◆ 檢查Keypad連接線
tunE	電動機參數調適失敗 (tunE) {24}	<ul style="list-style-type: none"> ◆ 檢查電動機接線是否正確 ◆ 變頻器的輸出容量與電動機容量是否懸殊 ◆ 重新檢查配線及參數後再執行
bF	動能煞車迴路異常 (bF) {25}	<ul style="list-style-type: none"> ◆ 將變頻器的電源切斷後，待顯示幕熄滅後再重新上電後，若再次出現異常則送廠維修。
PG	PG斷線/異常 (PG) {26}	<ul style="list-style-type: none"> ◆ 檢查PG連接線 ◆ 檢查電動機有無堵死
PHL	變頻器內部DC-Bus連波電壓過高 (電源欠相) (PHL) {27}	<p>電源輸入異常所引起:</p> <ul style="list-style-type: none"> ◆ 檢查電源電壓是否正常 ◆ 檢查電源三相電壓是否平衡 ◆ 檢查電源輸入端點螺絲是否鎖緊 ◆ 是否三相電源機種只接單相電源或欠相 <p>直流濾波電容異常所引起:</p> <ul style="list-style-type: none"> ◆ 檢查直流濾波電容是否已老化
CC	停機中電流訊號異常, 電流偵測硬體電路異常 (CC) {28}	<ul style="list-style-type: none"> ◆ 偶爾發生且復歸後即恢復正常, 為雜訊干擾。 ◆ 復歸無效則送廠維修
CPu	變頻器偵測線路異常 (CPu) {29}	<ul style="list-style-type: none"> ◆ 將變頻器的電源切斷後，待顯示字幕熄滅後再重新上電，若再次出現異常則送廠維修。
FAn	散熱風扇異常 (FAn) {30}	<ul style="list-style-type: none"> ◆ 檢查風扇是否被堵住 ◆ 更換風扇

An 1	類比輸入信號異常 (AnI.) {31}	◆ 檢查類比輸入信號是否超出範圍
ot2	過轉矩2檢出動作 (ot2) {32}	◆ 檢查電動機2負載是否過大 ◆ 檢查(Pr5-40) 電動機2額定電流值是否適當 ◆ 檢查過轉矩檢出位準1設定值(Pr5-21~Pr5-23) ◆ 機械負載是否異常 ◆ 增加電動機2容量, 選用較大輸出容量變頻器
oL2	電動機2 過負載 (oL2) {33} (電子熱動電驛2保護)	◆ V/F 2曲線設定是否適當 ◆ 是否長時間低速運轉 ◆ 檢查電動機2是否過載 ◆ 檢查(Pr5-40) 電動機1額定電流值是否適當 ◆ 檢查電子熱動電驛1功能設定(Pr5-45~ Pr5-46) ◆ 增加電動機2容量
rnot	電動機切換異常 (rnot) {34}	◆ 檢查電動機接線是否正確 ◆ 檢查參數設定是否正確
LUr	運轉中DC-bus低電壓 (LUr) {36}	◆ 檢查輸入電源電壓及配線是否正常 ◆ 檢查電源容量及電源系統是否不足 ◆ 檢查負載是否有突然的重載 ◆ 是否三相電源機種只接單相電源或欠相
LU	DC-bus低電壓 (LU) {39}	◆ 檢查輸入充電限流迴路是否正常 ◆ 檢查運轉中輸入電源是否中斷 ◆ 電源側電磁接觸器是否不良或故障 ◆ 同一電源系統中是否有大容量馬達起動
bb	外部中斷 (bb) {40}	◆ 當外部多功能輸入端子(MI1~MI6=15或16)有設定此外部中斷功能動作時, 變頻器停止輸出, 清除外部中斷信號後” bb” 立刻消失。
1 CoPy	操作器PU-02的 EEPROM 故障 (1 CoPy)	◆ 更換新品
2 CoPy	操作器PU-02內沒有資料, 無法存入 (2 CoPy)	◆ 請確認操作器PU-02資料存入後, 再執行COPY動作。
3 CoPy	機種型號不同不能存入 (3 CoPy)	◆ 再確認變頻器機種型號
4 CoPy	操作器PU-02的參數錯誤 (4 CoPy)	◆ 參數內容超出範圍, 再確認PU-02參數內容的正確性。
7 CoPy	RUN狀態下不能做存入 (7 CoPy)	◆ 請在STOP狀況下再執行COPY動作
8 CoPy	參數或密碼鎖定不能讀出或存入 (8 CoPy)	◆ 請先解除參數或密碼鎖定後再執行COPY動作

外觀尺寸:

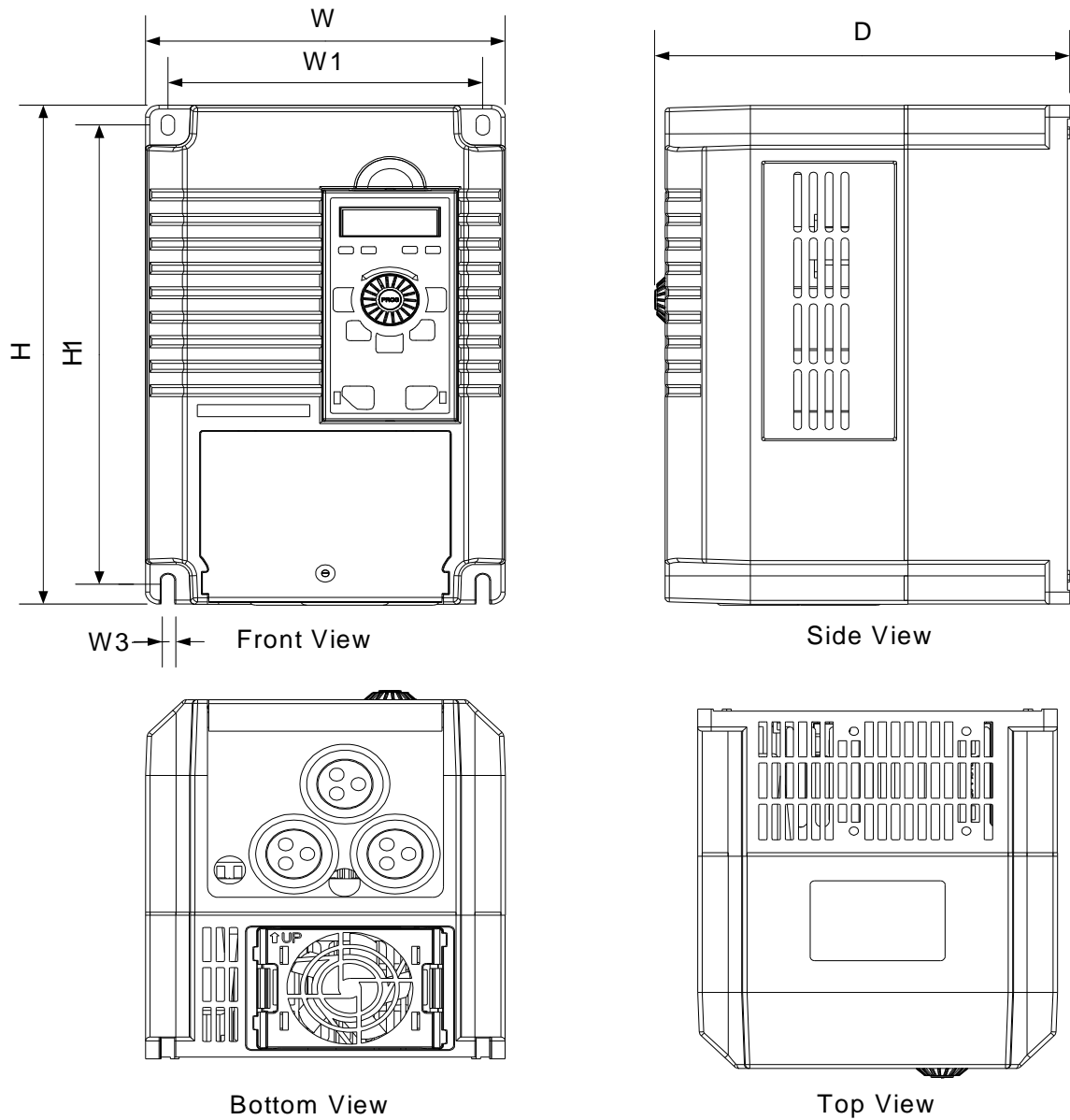

Unit: mm (inch)

框號	W	H	D	W1	W3	H1
G1-A,H1-A,P1-A	160.0 (6.30)	250.0 (9.84)	186.0 (7.32)	140.0 (5.51)	6.0 (0.24)	230.0 (9.06)
G1-B,H1-B,P1-B	200.0 (7.87)	275.0 (10.83)	206.0 (8.11)	180.0 (7.87)	6.0 (0.24)	255.0 (10.83)
G1-C,H1-C,P1-C	260.0 (10.24)	460.0 (18.11)	245.0 (9.65)	236.0 (9.29)	9.0 (0.35)	440.0 (17.32)

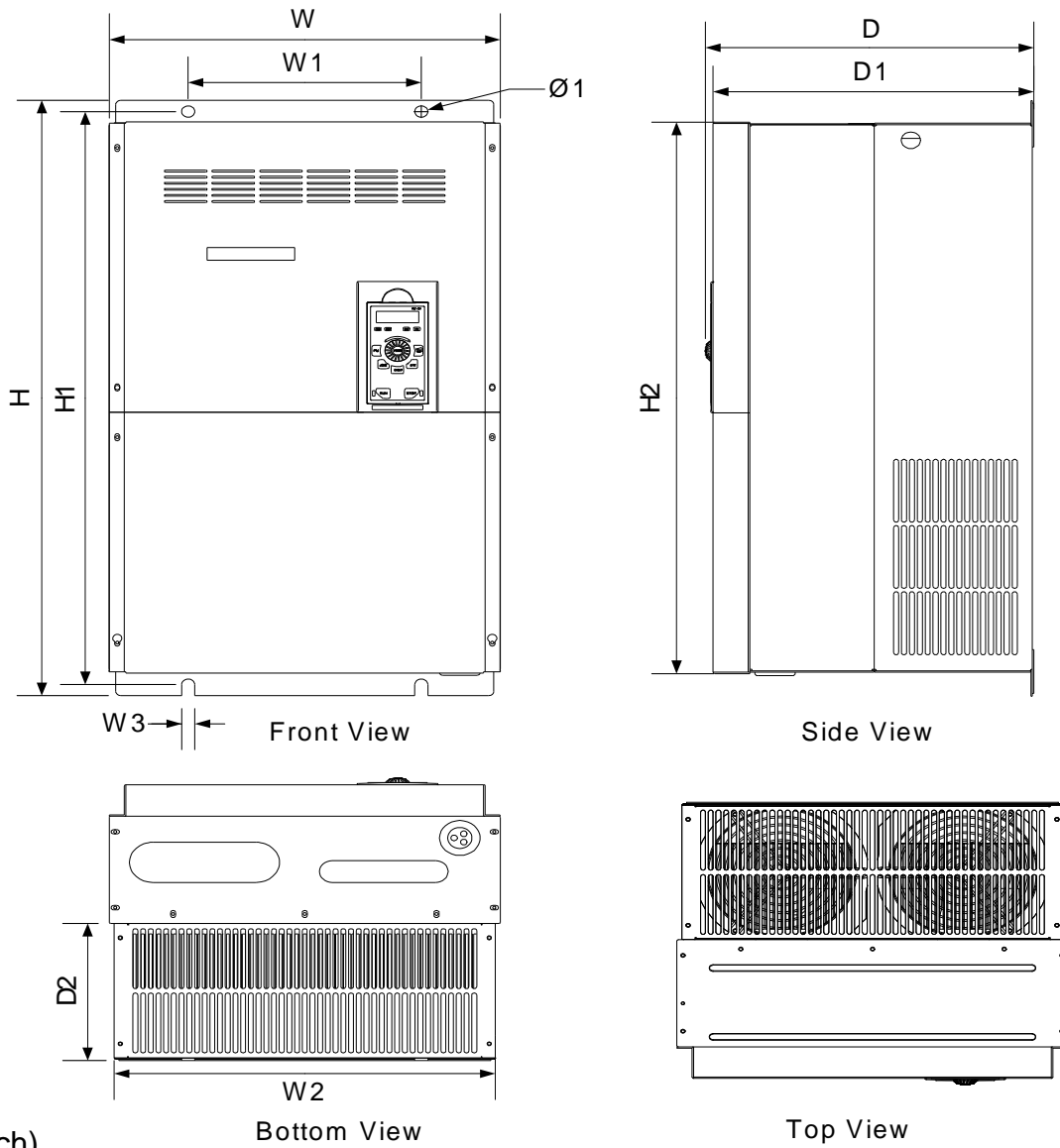

Unit: mm (inch)

框號	W	H	D	W1	W2	W3	H1	H2	D1	D2	$\Phi 1$
G1-D	386.0	617.0	298.3	230.0	376.0	13.0	591.5	566.5	290.5	131.5	13
H1-D	(15.20)	(24.29)	(11.74)	(9.06)	(14.80)	(0.51)	(23.29)	(22.30)	(11.44)	(5.18)	(0.51)
P1-D											
G1-E	386.0	683.0	324.3	230.0	376.0	13.0	657.5	632.5	316.5	157.5	13
H1-E	(15.20)	(26.89)	(12.77)	(9.06)	(14.80)	(0.51)	(25.89)	(24.90)	(12.46)	(6.20)	(0.51)
P1-E											
G1-F	496.0	810.0	352.1	260.0	484.0	13.0	784.0	764.0	344.0	180.5	13
H1-F	(19.53)	(31.89)	(13.86)	(10.24)	(19.06)	(0.51)	(30.87)	(30.08)	(13.54)	(7.11)	(0.51)
P1-F											
G1-G	732	1196	413	410	720.0	13.0	1156	1133	404.9	177.30	13
H1-G	(28.82)	(47.09)	(16.26)	(16.14)	(28.35)	(0.51)	(45.51)	(44.61)	(15.94)	(6.98)	(0.51)
P1-G											
G1-H											
H1-H											
P1-H											

陽岡科技股份有限公司
TOPTEK ELECTRONICS CORPORATION

台灣省 桃園縣 中壢市 自強六路1號 (中壢工業區)
No.1, Tzu-Chiang 6 Road,
Chung-Li City, Taoyuan Hsien
Taiwan

Tel: +886-3-462-9199 Fax: +886-3-462-8829
<http://www.toptek.biz> E-mail: tt@toptek.biz

ML-QSG1/H1/P102

Date Code: 3603